

BLU-JET NH3 Applicator
BY UNVERFERTH



6120

Serial Number A71420100 & Higher

Part No. 47951

Refer to Part No. 47952 for Parts Catalog

Foreword



This symbol identifies important safety messages. When you see it, read the message that follows and be alert to the possibility of personal injury.

Remember, safety instructions stated in this manual are for your protection. Read them carefully and follow them closely when working around or using this machine.

Read and study this manual completely before attempting to operate this implement. Take this manual to the field for handy reference when operating, adjusting, or servicing your machine.

When referenced, “Right-Hand” (RH) and “Left-Hand” (LH) side of the machine are determined by standing behind the machine and facing in the direction of travel.

Pre-Delivery Checklist

- Hardware tightened
- Machine lubricated
- Safety and operating procedures reviewed
- Field adjustment information reviewed
- Warranty information reviewed

IMPORTANT

The information, specifications, and illustrations in the manual are based on the information available at the time it was written. Due to continuing improvements in the design and manufacture of Unverferth products, all specifications and information contained herein are subject to change without notice.

Product Information

When ordering parts or when requesting further information or assistance, always give the following information:

- Machine name
- Model
- Serial number

All products manufactured by Blu-Jet are warranted to be free from material and workmanship defects for one full year from time of consumer delivery. Your local dealer will gladly assist you with any warranty questions.

Please fill out and retain this portion for your records.

Purchase Date _____ Model _____ Serial Number _____

Dealer _____ City _____

Dealer Contact _____ Phone _____

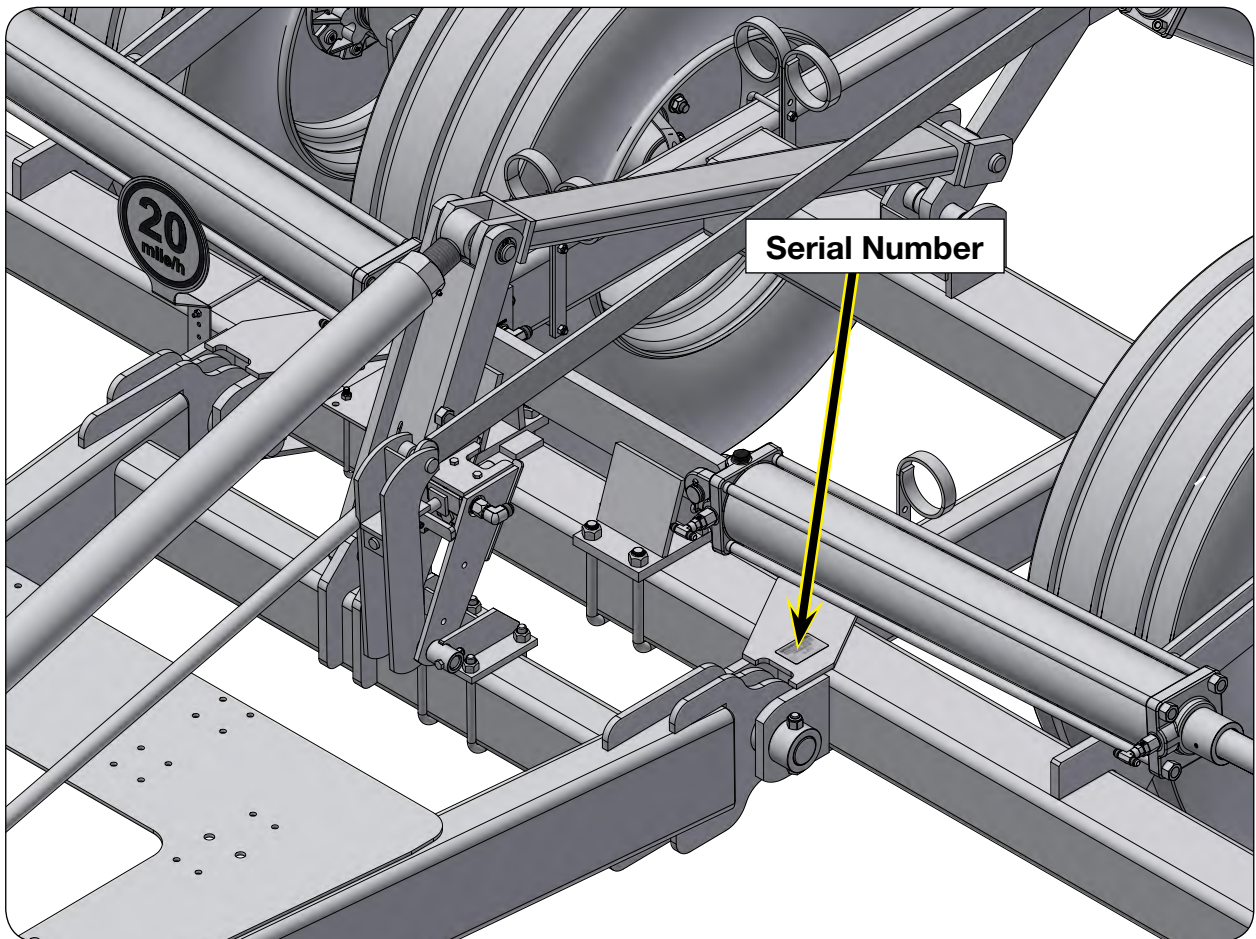

TABLE OF CONTENTS

Foreword	2
Pre-Delivery Checklist.....	2
Product Information	3

SECTION I

Safety

General Hazard Information	1-2
Safety Decals.....	1-3
Following Safety Instructions.....	1-6
Before Servicing or Operating.....	1-7
During Operation.....	1-7
Before Transporting.....	1-8
During Transport	1-8
Pressurized Oil.....	1-9
Chemical Hazards	1-9
Anhydrous Ammonia (NH ₃).....	1-10
Clean Water Tank	1-11
Preparing for Emergencies	1-11
Wearing Protective Equipment.....	1-11

SECTION II

Set Up

Set Up	2-2
Tongue Assembly to Main Frame Assembly	2-3
Attaching Hydraulics	2-5
Nurse Tank Hitch Assembly.....	2-6
Transport Lighting Assembly.....	2-7
SMV Assembly	2-11
Mounting Offset Stagger & Double Extension Brackets	2-12
Sealer II Assembly (47615B) - Optional Sealer II Spring Add-On Kit (47616B)	2-13
Torsion Arm Assembly	2-14
Attaching Bearings and Basket to Mounting Arms	2-14
Position Basket on Torsion Spring Assembly.....	2-14
Center Basket.....	2-15
Attaching Torsion Arm Assembly to MaxPac Basket Mount Arm.....	2-15
Attaching Torsion Arm Assembly to 6"x6" Tube (JAAM2630).....	2-16
MaxPac AR700 Assembly	2-17
DiscCover Sealer Assembly	2-18
Setting The Implement For Field Operation.....	2-19
6120 Toolbars.....	2-21
Overhead Layouts.....	2-22
AgLeader RCM Guide	2-35

TABLE OF CONTENTS

SECTION III

Operation

Preparing Tractor	3-2
Preparing Applicator.....	3-2
Hardware.....	3-2
Pivot Pins	3-2
Hitch	3-2
Hydraulic System.....	3-2
Tires/Wheels.....	3-3
Lubrication	3-3
Hitching to the Tractor.....	3-4
Drawbar Hitching.....	3-4
Transport Chain	3-5
Hydraulic Connections.....	3-6
Electrical Connection	3-6
Jack Usage.....	3-7
Parked Position.....	3-7
Transport Position	3-7
Transporting	3-8
Drawbar Connection	3-8
Toolbar Operation.....	3-9
Leveling Machine.....	3-9
Leveling Adjustable Gauge Wheels.....	3-10
Swing Adjust Gauge Wheels	3-11
Depth Adjustment	3-12
Locking Depth Adjustment Linkage.....	3-12
Hydraulic System Charging.....	3-13
Folding Toolbar.....	3-14
Secondary Wing Latch.....	3-15
Nurse Tank Hitch.....	3-15
Anhydrous Ammonia Operating Instructions	3-16
Checking System.....	3-17
Connecting Nurse Tank	3-17
Orifice Black Setting	3-18
Disconnecting Nurse Tank.....	3-19
Clean Water Tank	3-20
DiscCover Sealer (Options).....	3-20
Torsion Arm Basket (Options).....	3-20
SuperShooter (Options)	3-21
MaxPac AR700 (Options)	3-21
Residue Manager (Options).....	3-21
Operational Guide For Various Residue Situations.....	3-22

TABLE OF CONTENTS

SECTION IV

Maintenance

Lubrication	4-2
Hydraulics	4-4
Purging A Hydraulic System.....	4-4
6120 Maintenance	4-5
Seasonal Storage.....	4-6
NH3 Bleed Procedure	4-7
Coupler Operations	4-10
Electrical Layout - AgLeader Rate Controller.....	4-12
Electrical Layout - Raven 450 Rate Controller.....	4-13
Electrical Layout - Lighting.....	4-14
Schematics - Electrical	4-15
Electrical Harness - Limit Switch Assembly (416395).....	4-15
Electrical Harness - 450 Console Controller (9007549).....	4-16
Electrical Harness - 12 Ft. Extension (9503392) - For On/Off Valve.....	4-17
Electrical Harness - 24 Ft. Extension (9503393) - For On/Off Valve.....	4-17
Electrical Harness - Console 10 Ft. (9503395) - Transducer to Console.....	4-18
Electrical Harness - 16 Pin Console to 47 Pin Connector (9503396).....	4-19
Electrical Harness - RCM Accu-Flow - 3 Section (9504612).....	4-20
Electrical Harness - RCM Accu-Flow - 6 Section (9504613).....	4-21
Electrical Harness - 16 Ft. Front IBIC (9505086).....	4-22
Electrical Harness - Flow Control Cable (9505087).....	4-23
Electrical Harness - Swath Control - 6 Section (9505088)	4-24
Electrical Harness - ISOBUS Breakout (9505089).....	4-25
Electrical Harness - Local CAN Breakout (9505090).....	4-26
Electrical Harness - ISO Switchbox Metripack Tee (9505092)	4-27
Electrical Harness - ISO Active Imp Termination (9505093).....	4-27
Electrical Harness - CAN Implement Switch Cable (9505100).....	4-28
Electrical Harness - Main 33' (JAP3221).....	4-28
Electrical Harness - Rear 27' (JAP3222)	4-29
Electrical Harness - AG Plug to RV Socket (JAP3223).....	4-29
Wheel, Hub and Spindle Disassembly and Assembly.....	4-30
Wheels and Tires.....	4-32
Wheel Nut Torque Requirements.....	4-32
Tire Pressure	4-33
Tire Warranty.....	4-34
Complete Torque Chart.....	4-35
Hydraulic Fittings - Torque and Installation.....	4-37
NH3 Fittings - Torque and Installation.....	4-39

SECTION I

Safety

General Hazard Information	1-2
Safety Decals.....	1-3
Following Safety Instructions.....	1-6
Before Servicing or Operating.....	1-7
During Operation.....	1-7
Before Transporting.....	1-8
During Transport	1-8
Pressurized Oil.....	1-9
Chemical Hazards	1-9
Anhydrous Ammonia (NH ₃).....	1-10
Clean Water Tank	1-11
Preparing for Emergencies	1-11
Wearing Protective Equipment.....	1-11

General Hazard Information

No accident-prevention program can be successful without the wholehearted cooperation of the person who is directly responsible for the operation of the equipment.

A large number of accidents can be prevented only by the operator anticipating the result before the accident is caused and doing something about it. No power-driven equipment, whether it be transportation or processing, whether it be on the highway, in the field, or in the industrial plant, can be safer than the person who is at the controls. If accidents are to be prevented--and they can be prevented--it will be done by the operators who accept the full measure of their responsibility.

It is true that the designer, the manufacturer, and the safety engineer can help; and they will help, but their combined efforts can be wiped out by a single careless act of the operator.

It is said that, "the best kind of a safety device is a careful operator." We, at Unverferth Mfg. Co., Inc. ask that you be that kind of operator.



REMEMBER:
THINK SAFETY
 A CAREFUL OPERATOR IS THE
 BEST INSURANCE AGAINST AN
 ACCIDENT!

SIGNAL WORDS



INDICATES AN EXTREMELY HAZARDOUS SITUATION OR ACTION THAT WILL RESULT IN SERIOUS INJURY OR DEATH.



INDICATES A HAZARDOUS SITUATION OR ACTION THAT COULD RESULT IN SERIOUS INJURY OR DEATH.



INDICATES AN UNSAFE SITUATION OR ACTION THAT MAY RESULT IN PERSONAL INJURY.



Is used for instruction on operating, adjusting, or servicing a machine.

Safety Decals

⚠ WARNING

- REPLACE LOST, DAMAGED, PAINTED, OR UNREADABLE DECALS IMMEDIATELY. IF PARTS THAT HAVE DECALS ARE REPLACED, ALSO MAKE SURE TO INSTALL NEW DECALS. THESE DECALS INFORM AND REMIND THE OPERATOR WITH OPERATIONAL INFORMATION AND SAFETY MESSAGES.

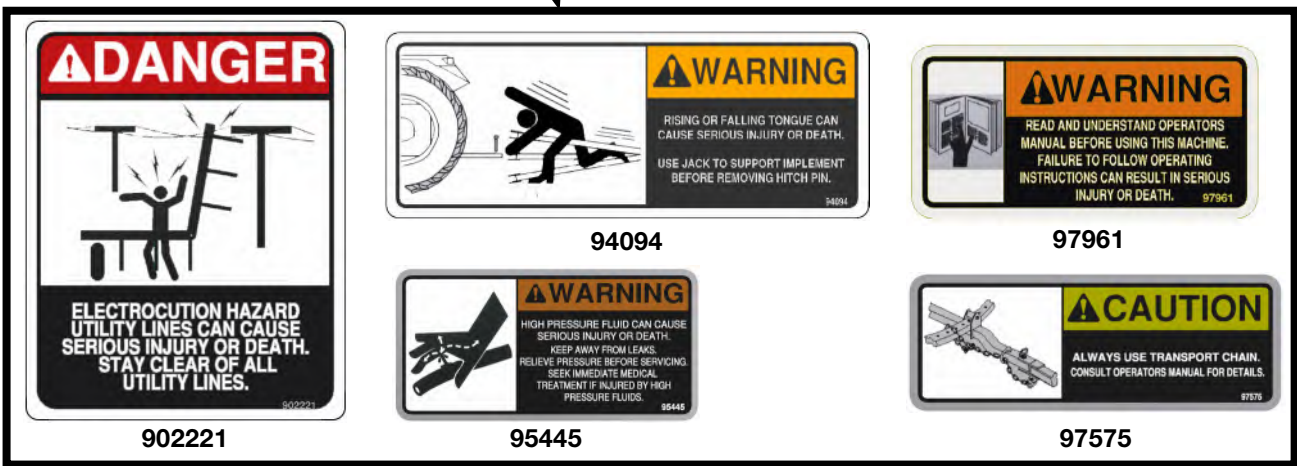
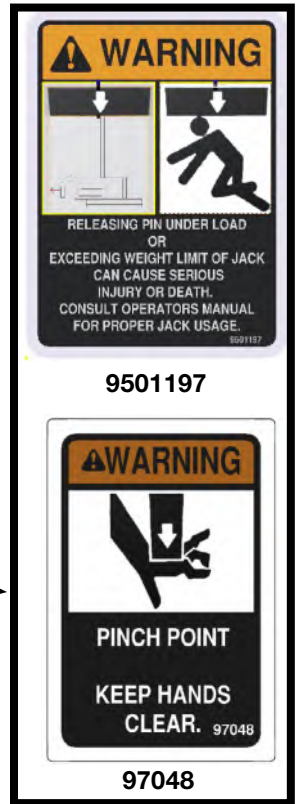
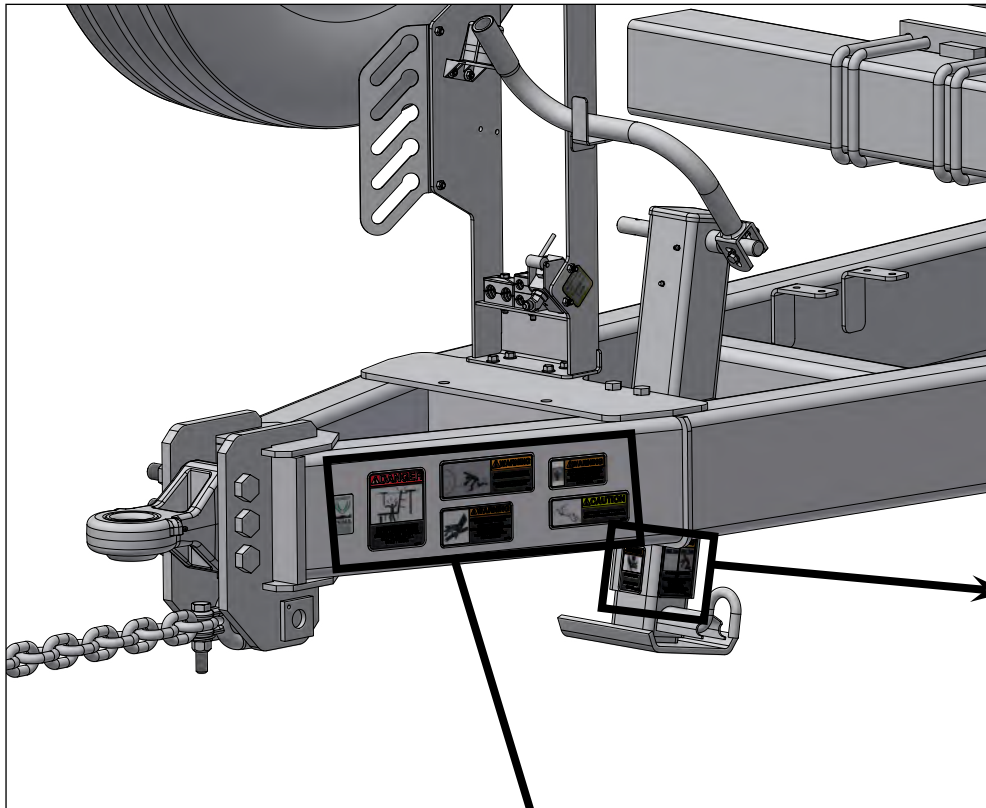

(Continued)

Safety Decals (continued)

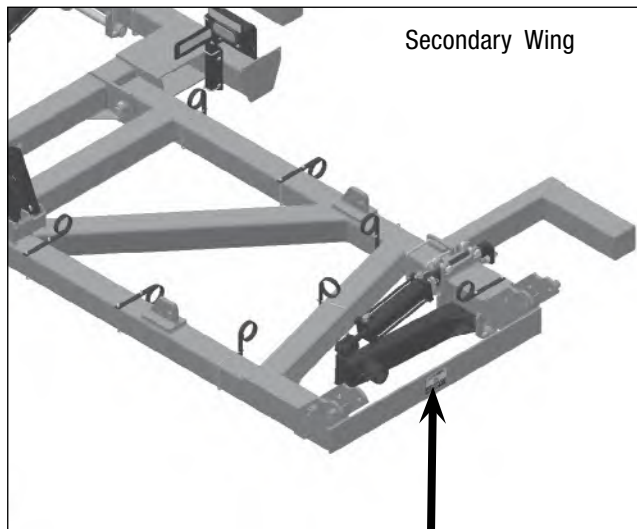
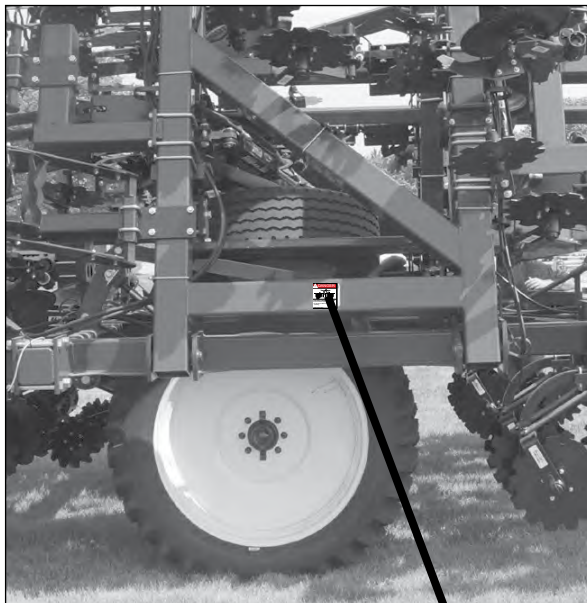

97337



9003125 - Fluorescent Strip



9003126 - Reflector RED



9003127 - Reflector AMBER

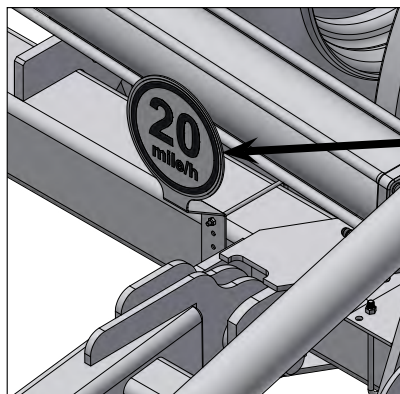

9008714



JAP2585

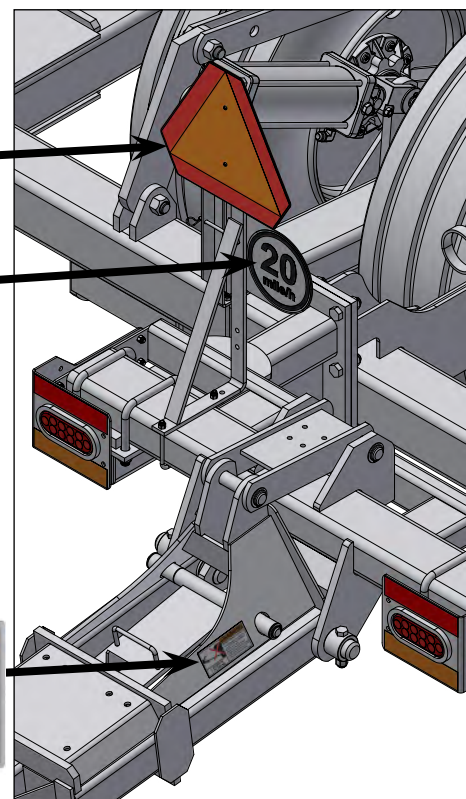

(Continued)

Safety Decals (continued)

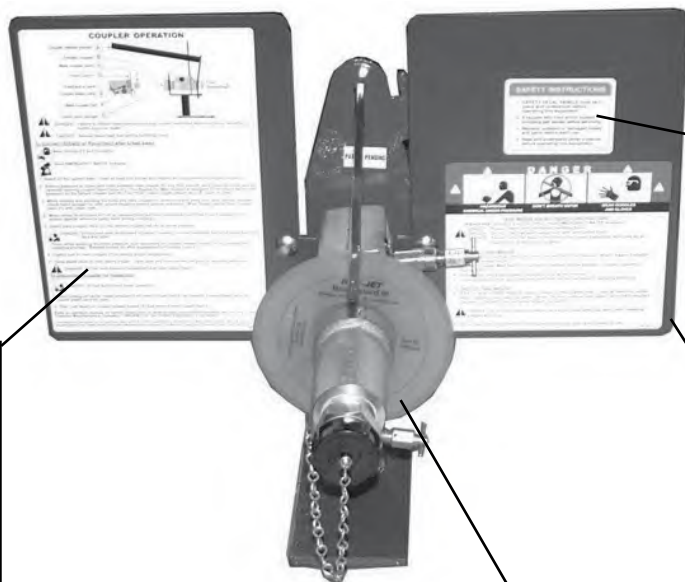

SAFETY INSTRUCTIONS

1. SAFETY DECAL PANELS must be in place and understood before operating this equipment.
2. Evacuate NH₃ from entire system, including ball valves, before servicing.
3. Replace outdated or damaged hoses and parts before each use.
4. Read and understand owner's manual before operating this equipment.

AP 2227

JAP2227

HAZARDOUS CHEMICAL UNDER PRESSURE DANGER DON'T BREATH VAPOR WEAR GOGGLES AND GLOVES

TANK WAGON and NH₃ HOOK-UP INSTRUCTIONS

1. Always wear **GOGGLES** and **GLOVES**. Have **EMERGENCY WATER** available.
DANGER: Always bleed feed-line before handling hose.
DANGER: Do not road transport equipment with tank valves open.
DANGER: Failure to follow these instructions may cause hazardous ammonia spray resulting in bodily injury or death.

TO CONNECT TANK WAGON:

2. Hitch wagon to toolbar using your hitch pin and hitch pin retainer. Attach wagon transport chains to toolbar hitch.
3. If Safety Coupler Male Half is not properly inserted, follow adjacent "Coupler Operation" instructions.
4. Screw hose and acme thread connection onto acme receiver.
5. Close all bleed valves and open tank and hose valves just prior to applying ammonia.

TO UNHOOK TANK WAGON:

6. Park on level surface. Refer to step 1. Stand on the upwind side. Close all feed-line valves; then, carefully open feed-line bleed valves. Do not continue until bleed valves have emptied.
7. Carefully unscrew hose end acme thread connection.

DANGER: Do not carry hose by holding valve knob. Hose twist may open valve releasing trapped ammonia.

8. Store hose and secure wisely, avoiding improper hose and valve contact points.

AP 2973

JAP2973

COUPLER OPERATION

Check valve plunger (G)

DANGER: Failure to follow these Instructions may cause hazardous ammonia spray resulting in bodily injury or death.

DANGER: Always bleed feed-line before handling hose.

To Connect Initially or Reconnect after break-away:

- Wear **GOGGLES** and **GLOVES**.
- Have **EMERGENCY WATER** available.

1. Stand on the upwind side. Close all feed-line valves and inspect all components for proper condition.
2. Relieve pressure in nurse tank hose between male coupler (F) and first shutoff valve towards nurse tank by carefully opening coupler bleed valve (E). The Squibb Flo-Max coupler is designed to re-couple safely with pressure on the female coupler half (B). **CAUTION:** Leave coupler bleed valve (E) open for now.
3. While holding and pointing the hose and male coupler (F) downwind and away from your person, depress check valve plunger (G) with gloved finger to ensure proper operation. Wipe foreign debris from coupler neck (C) with clean cloth.
4. Make certain BodyGuard III™ (D) is installed fully with slot oriented around check valve plunger (G) to protect against ammonia spray-back during coupling.
5. Insert male coupler neck (C) into female coupler half (B) as far as possible.

DANGER: Do not look past BodyGuard (D) when coupling to avoid possible ammonia spray-back into face and eyes.

Then, while applying insertion pressure, pull downward on coupler release handle (A) to complete the coupling process. Release handle (A) after engagement of coupler neck (C).

6. Lightly pull on male coupler (F) to ensure proper engagement.
7. Close bleed valve (E) and others if open. Open tank and hose valves just prior to applying ammonia.

DANGER: Do not road transport equipment with tank valves open.

To Disconnect coupler for inspection:

DANGER: Do not disconnect under pressure.

1. After closing all valves, bleed pressure from male coupler half (F) by opening coupler bleed valve (E). Leave bleed valve (E) open.
2. Then, pull down on coupler release handle (A) and remove male coupler half (F).

JAP2974



9503899 - 1 1/4" Connection
9503900 - 1 1/2" Connection

Following Safety Instructions

- Read and understand this operator's manual before operating.



- All machinery should be operated only by trained and authorized personnel.

- To prevent machine damage, use only attachments and service parts approved by the manufacturer.

- Always shut tractor engine off and remove key before servicing.

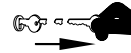

- Avoid personal attire such as loose fitting clothing, shoestrings, drawstrings, pants cuffs, long hair, etc., that may become entangled in moving parts.

- Do not allow anyone to ride on the implement. Make sure everyone is clear before operating machine or towing vehicle.



- Never attempt to operate implement unless you are in driver's seat.



Before Servicing or Operating

- Avoid working under an implement; however, if it becomes absolutely unavoidable, make sure the implement is safely blocked. 
- Ensure that all applicable safety decals are installed and legible.
- Sharp edges on the machine can cause injury. Be careful when working around the machine.
- Explosive separation of a tire and rim can cause serious injury or death. Only properly trained personnel should attempt to service a tire and wheel assembly.
- Add sufficient ballast to tractor to maintain steering and braking control at all times. Do not exceed tractor's lift capacity or ballast capacity.
- Hitch applicator to towing vehicle and clear all personnel from the surrounding area before folding and unfolding wings.
- Check all applicator equipment for leaks. Repair any leaks before beginning or resuming operation.
- Residual pressure may exist in applicator plumbing even when unit is not in use. Remove pressure before servicing any plumbing.
- Do not stand between towing vehicle and implement during hitching.
- Always make certain everyone and everything is clear of the machine before beginning operation.
- Verify that all safety shields are in place and properly secured.
- This applicator is intended to apply only agricultural fertilizers. Attempting to apply other liquids may cause equipment damage and introduce unexpected personal hazards.
- Hitch applicator to towing vehicle and clear all personnel from the surrounding area before folding and unfolding wings.
- Hot parts can cause severe burns. Use caution when working around power system/ground engaging components. Allow parts to cool before servicing.

During Operation

- Regulate speed to working conditions. Maintain complete control at all times.
- Never service or lubricate equipment when in operation.
- Keep away from overhead power lines. Electrical shock can cause serious injury or death.
- Use extreme care when operating close to ditches, fences, or on hillsides.
- Do not leave towing vehicle unattended with engine running.

Before Transporting

- Secure transport chains to towing vehicle before transporting. DO NOT transport without chains.
- Install transport locks before transporting.
- Check for proper function of all available transport lights. Make sure that all reflectors are clean and in place on machine. Make sure that the SMV emblem and SIS decal are visible to approaching traffic.
- This implement may not be equipped with brakes. Ensure that the towing vehicle has adequate weight and braking capacity to tow this unit.

During Transport

- Follow all federal, state and local regulations governing highway safety and transporting chemicals.
- Use transport lights as required by all laws to adequately warn operators of other vehicles.
- Regulate speed to road conditions and maintain complete control.
- Maximum transport speed of this implement should never exceed 20 mph as indicated on the machine. Maximum transport speed of any combination of implements must not exceed the lowest specified speed of the implements in combination. Do not exceed 10 mph during off-highway travel.
- Slow down before making sharp turns to avoid tipping. Drive slowly over rough ground and side slopes.
- It is probable that this implement is taller, wider and longer than the towing vehicle. Become aware of and avoid all obstacles and hazards in the travel path of the equipment, such as power lines, ditches, etc.

Pressurized Oil

- Relieve the hydraulic system of all pressure before adjusting or servicing. See hydraulic power unit manual for procedure to relieve pressure.

- High-pressure fluids can penetrate the skin and cause serious injury or death. Leaks of high-pressure fluids may not be visible. Use cardboard or wood to detect leaks in the hydraulic system. Seek medical treatment immediately if injured by high-pressure fluids. 

- Hydraulic system must be purged of air before operating to prevent serious injury or death.

- Do not bend or strike high-pressure lines. Do not install bent or damaged tubes or hoses.

- Repair all oil leaks. Leaks can cause fires, personal injury, and environmental damage.

- Route hoses and lines carefully to prevent premature failure due to kinking and rubbing against other parts. Make sure that all clamps, guards and shields are installed correctly.

- Check hydraulic hoses and tubes carefully. Replace components as necessary if any of the following conditions are found:
 - End fittings damaged, displaced, or leaking.
 - Outer covering chafed/cut or wire reinforcing exposed.
 - Outer covering ballooning locally.
 - Evidence of kinking or crushing of the flexible part of a hose.

Chemical Hazards

- Always wear personal protective equipment when working with or near chemicals. This equipment includes, but is not limited to: protective eye wear, gloves, shoes, socks, long-sleeved shirt, and long pants. Additional protection may be required for many types of chemicals.

- Seek and receive chemical product training prior to using agricultural chemicals.

- Read and understand the entire label of every chemical being applied with this applicator.

- Avoid breathing applicator mist or vapor.

- Wash hands and exposed skin immediately after contact with spray/fertilizer solution and application equipment.

- Remove clothing immediately if chemicals penetrate clothing and contact skin. Wash thoroughly and put on clean clothing.

- Dispose of unused chemical in accordance with chemical label directions and local/national regulations.

Anhydrous Ammonia (NH₃)

- Exposure to anhydrous ammonia (NH₃) will cause serious injury or death. Anhydrous ammonia causes severe burns to the eyes, skin, and respiratory system. Immediately flush exposed areas with fresh water and seek medical treatment.
- It is important that all personnel understand the properties of anhydrous ammonia, and that they be thoroughly trained in safe practices for its storage, transferring, transporting, and otherwise handling. Train all personnel in safe operating practices and take appropriate actions in the event of a leak or an emergency. Consult proper authorities for anhydrous ammonia training and documentation.
- Pressure gauges can fail or plug. Do not rely on gauge readings to indicate presence of anhydrous ammonia in a system. Treat all plumbing sections as if anhydrous ammonia is present. See MAINTENANCE section for proper bleeding procedures.
- Liquid anhydrous ammonia trapped in the plumbing can absorb heat from surroundings and unexpectedly pressurize the system.
- Never unhitch the anhydrous ammonia applicator from the tractor with a nurse tank attached.
- Always park applicator downwind from the operating station, other personnel, livestock, and nearby buildings before attempting to connect or disconnect tank hosing.
- Always remain upwind when depressurizing the system.
- Inspect all anhydrous ammonia valves, couplers, hoses, and other plumbing equipment prior to usage or storage. Repair or replace any component showing wear, damage, or as required per date stamp and manufacturer's instructions.
- When coupling a nurse tank and supply hose to the applicator for the first time, perform a test turn in both directions with the tank valve closed to verify sufficient slack in the hose allows free articulation. Do not allow hose to contact the wagon tongue or any other component during movement.
- In the event of a breakaway coupling device disconnection, inspect the breakaway device and all supporting structures and plumbing before resetting the coupler. Understand why the disconnection occurred and take action to limit reoccurrence.
- Immediately evacuate the area in the event of an anhydrous ammonia leak or accidental release. Prevent others from entering the area of the anhydrous ammonia leak.
- Ensure a readily accessible clean water tank with a minimum of 5 gallons of fresh water are available for first aid use.
- Always wear personnel protective equipment (PPE) when working with or near anhydrous ammonia. This equipment includes, but is not limited to:
 - Protective gauntlet style gloves impervious to anhydrous ammonia
 - Indirect vent chemical splash goggle
 - Shoes and socks
 - Long sleeved shirt
 - Long pants
 - A full-face shield is appropriate, but does not replace the need for the chemical splash goggles.
- Only open a nurse tank valve during application. Do not transport, park, or leave the applicator unattended with the valve open.

Clean Water Tank

- A clean water tank is provided as standard equipment. It is equipped with a spigot for general washing and a hose for emergency eye washing.
- Always keep clean water in tank. Water in clean water tank is not suitable for human consumption.
- For emergency eyewash, pull hose off of top fitting and flush affected area.

Preparing for Emergencies

- Keep a first aid kit and properly rated fire extinguisher nearby.
- Keep emergency numbers for fire, rescue, and poison control personnel near the phone.



Wearing Protective Equipment

- Wear clothing and personal protective equipment appropriate for the job.
- Wear steel-toed shoes when operating.
- Wear hearing protection when exposed to loud noises.
- Do not wear additional hearing impairing devices such as radio headphones, etc.



Notes

SECTION II

Set Up

Set Up	2-2
Tongue Assembly to Main Frame Assembly	2-3
Attaching Hydraulics	2-5
Nurse Tank Hitch Assembly.....	2-6
Transport Lighting Assembly.....	2-7
SMV Assembly	2-11
Mounting Offset Stagger & Double Extension Brackets	2-12
Sealer II Assembly (47615B) - Optional Sealer II Spring Add-On Kit (47616B)	2-13
Torsion Arm Assembly	2-14
Attaching Bearings and Basket to Mounting Arms	2-14
Position Basket on Torsion Spring Assembly.....	2-14
Center Basket.....	2-15
Attaching Torsion Arm Assembly to MaxPac Basket Mount Arm.....	2-15
Attaching Torsion Arm Assembly to 6"x6" Tube (JAAM2630).....	2-16
MaxPac AR700 Assembly	2-17
DiscCover Sealer Assembly	2-18
Setting The Implement For Field Operation.....	2-19
6120 Toolbars.....	2-21
Overhead Layouts	2-22
AgLeader RCM Guide	2-35

Set Up

WARNING

- **READ AND UNDERSTAND SAFETY RULES BEFORE OPERATING OR SERVICING THIS MACHINE. REVIEW THE SAFETY SECTION IN THIS MANUAL IF NECESSARY.**

- **TIPPING OR MOVEMENT OF THE MACHINE CAN CAUSE SERIOUS INJURY OR DEATH. BE SURE THE MACHINE IS SECURELY BLOCKED.**

- **KEEP HANDS CLEAR OF PINCH POINT AREAS.**

- **FALLING OBJECTS CAN CAUSE SERIOUS INJURY OR DEATH. DO NOT WORK UNDER THE MACHINE AT ANY TIME WHILE BEING HOISTED. BE SURE ALL LIFTING DEVICES AND SUPPORTS ARE RATED FOR THE LOADS BEING HOISTED. THESE ASSEMBLY INSTRUCTIONS WILL REQUIRE SAFE LIFTING DEVICES UP TO 7,000 LBS. SPECIFIC LOAD RATINGS FOR INDIVIDUAL LOADS WILL BE GIVEN AT THE APPROPRIATE TIME IN THE INSTRUCTIONS.**

- **EYE PROTECTION AND OTHER APPROPRIATE PERSONAL PROTECTIVE EQUIPMENT MUST BE WORN WHILE SERVICING THE IMPLEMENT.**

For your safety, and the safety of others, use proper tools and equipment and always use safe working procedures. Refer to these instructions before starting any work on the machine.

For ease of assembly, install all hardware loosely until assembly is complete and then tighten according to Torque Chart in the MAINTENANCE section of this manual.

Tongue Assembly to Main Frame Assembly

1. Using a safe lifting device rated for at least 2,000 lbs., secure tongue assembly to main frame with 2" Dia. x 10 1/4" pins (JBM3565), 5/8"-11UNC x 4" capscrews (9390-132), and 5/8"-11UNC elastic locknuts (9398-019). (FIG. 2-1)

FIG. 2-1

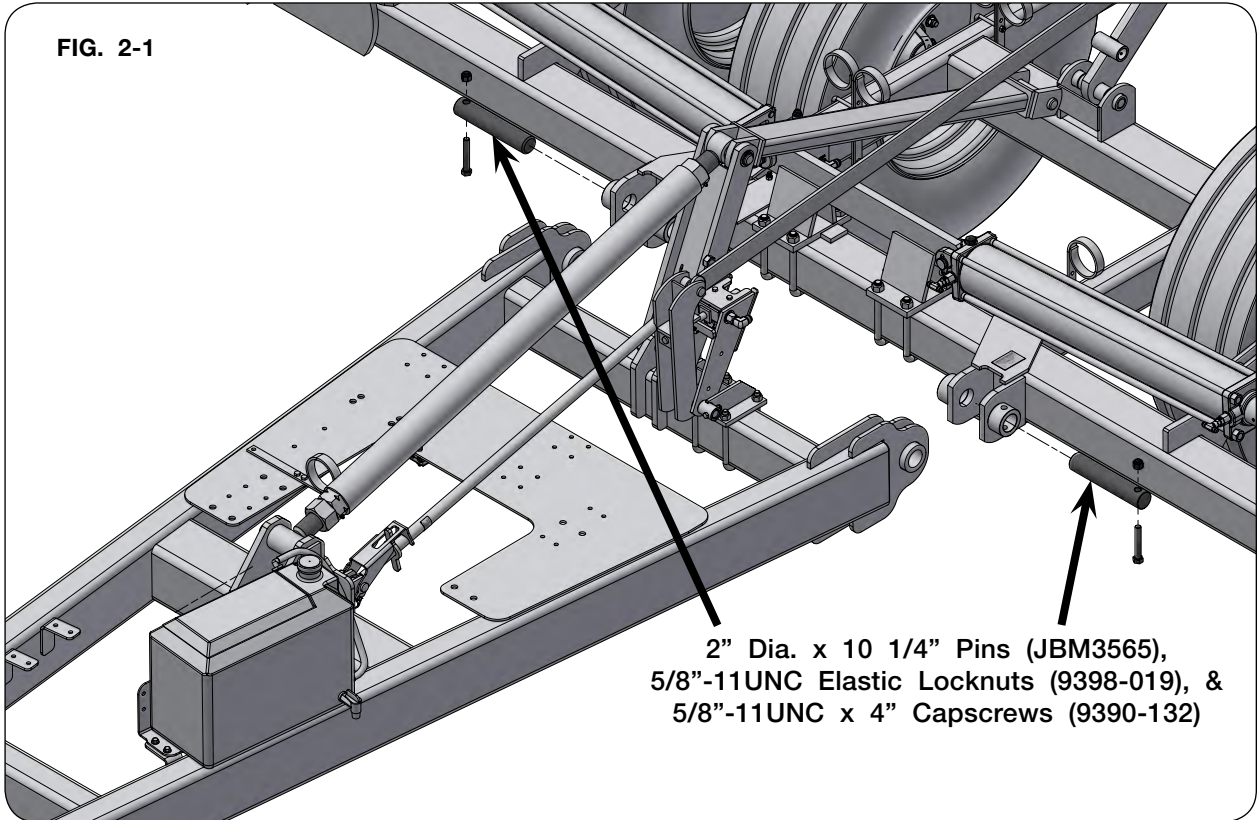

Tongue Assembly to Main Frame Assembly (continued)

2. Rotate tongue cylinder linkage (JAM6183) to the tongue cylinder arm linkage (JAM6182). Secure with 1 1/4" Dia. x 7 3/4" pin (JBM3465), 3/8"-16UNC x 2 1/2" capscrew (9390-061) and 3/8"-16UNC locknut (902875) (FIG. 2-2).

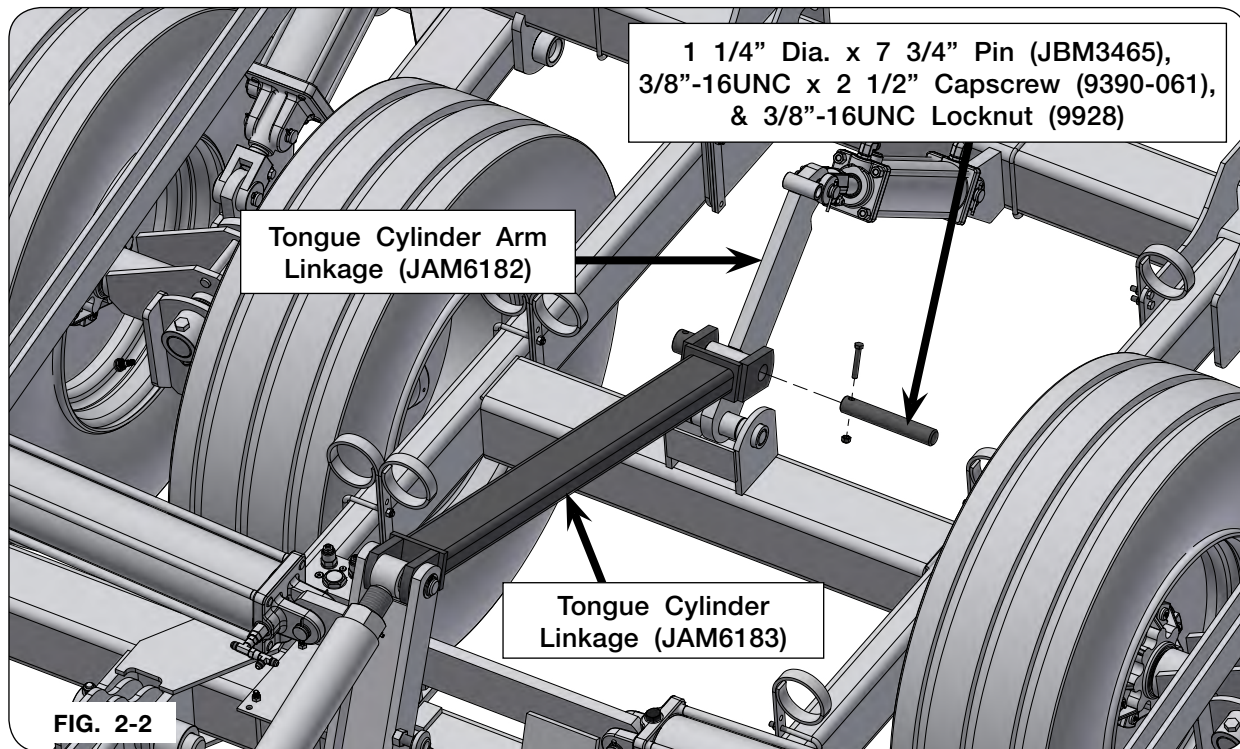

3. Rotate linkage stop weldment (JAM6266) to the tongue cylinder arm linkage (JAM6182). Secure with 3/4"-10UNC x 4 1/2" capscrew (9390-154) and 3/4"-10UNC locknut/center (96732) (FIG. 2-3).

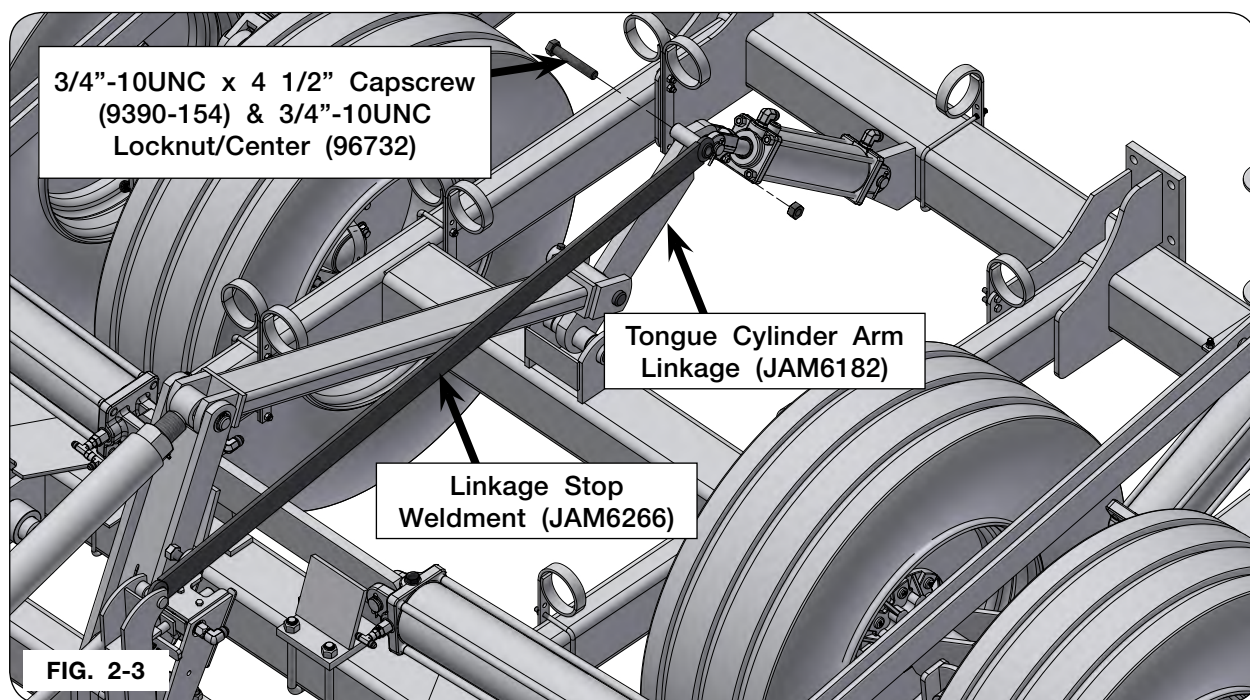

Attaching Hydraulics

1. Route the 1/2" x 264" hose (JDP5349) from the depth control valve (9504712) to the tractor. (FIG. 2-5)
2. Route the 3/8" x 230" hose (9504312) to the tractor. (FIG. 2-5)
3. Route the 1/2" x 240" hose (JDP5317) from the valve assembly to the tractor. (FIG. 2-5)

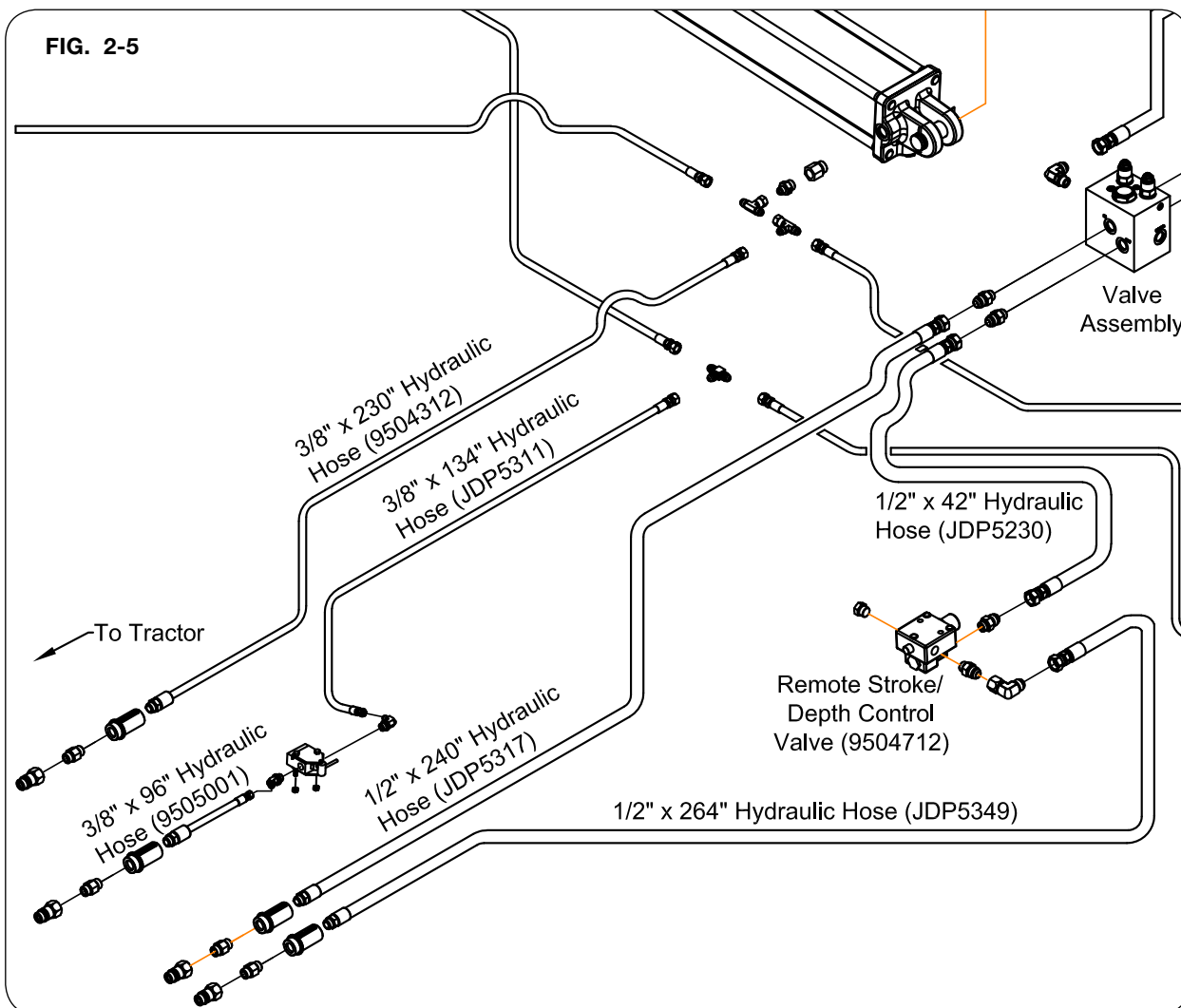

4. Route 3/8" x 134" hose (JDP5311) to hydraulic check valve (JDP3993).
5. Route 3/8" x 96" hose (9505001) from hydraulic check valve to tractor.

Nurse Tank Hitch Assembly

1. Using a safe lifting device rated at a minimum of 1000 lbs., attach the nurse tank hitch assembly to the main frame with twelve 3/4"-10UNC x 2 1/2" capscrews (9390-147) and 3/4"-10UNC locknuts (9802) (FIG. 2-6 or FIG. 2-7). Tighten hardware according to Torque Chart in MAINTENANCE section.
2. After installation of all the NH3 plumbing components, the entire NH3 system needs to be tested and proven to be free from leaks before being put into service.

Nurse Tank Hitch Assembly & Single SuperShooter

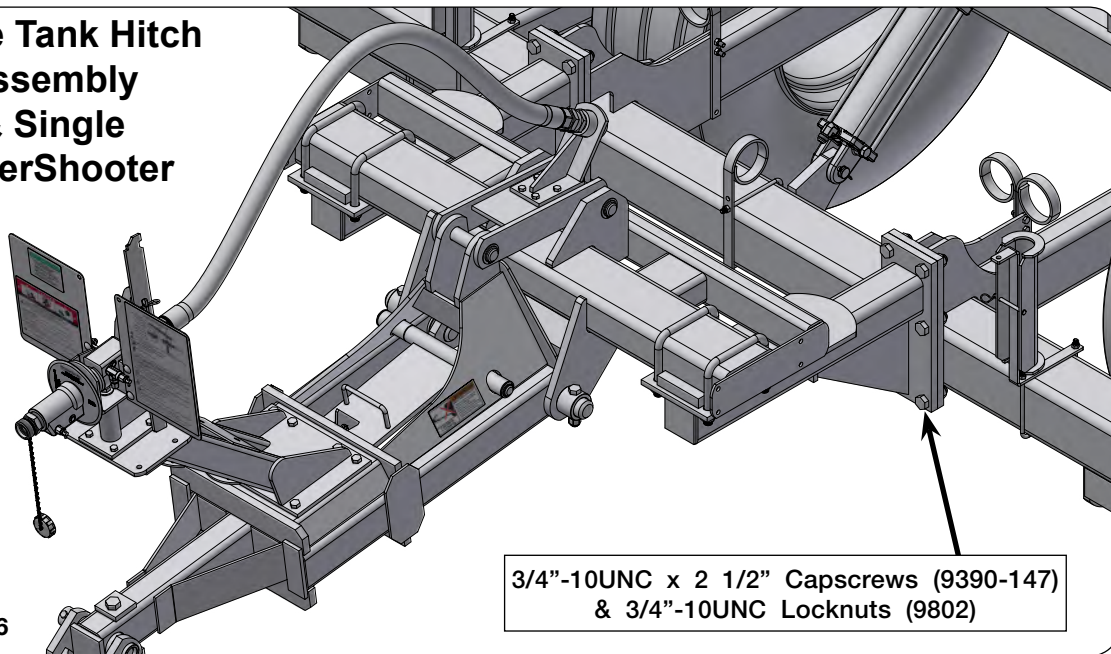

FIG. 2-6

Nurse Tank Hitch Low Mounting Assembly & Double SuperShooter

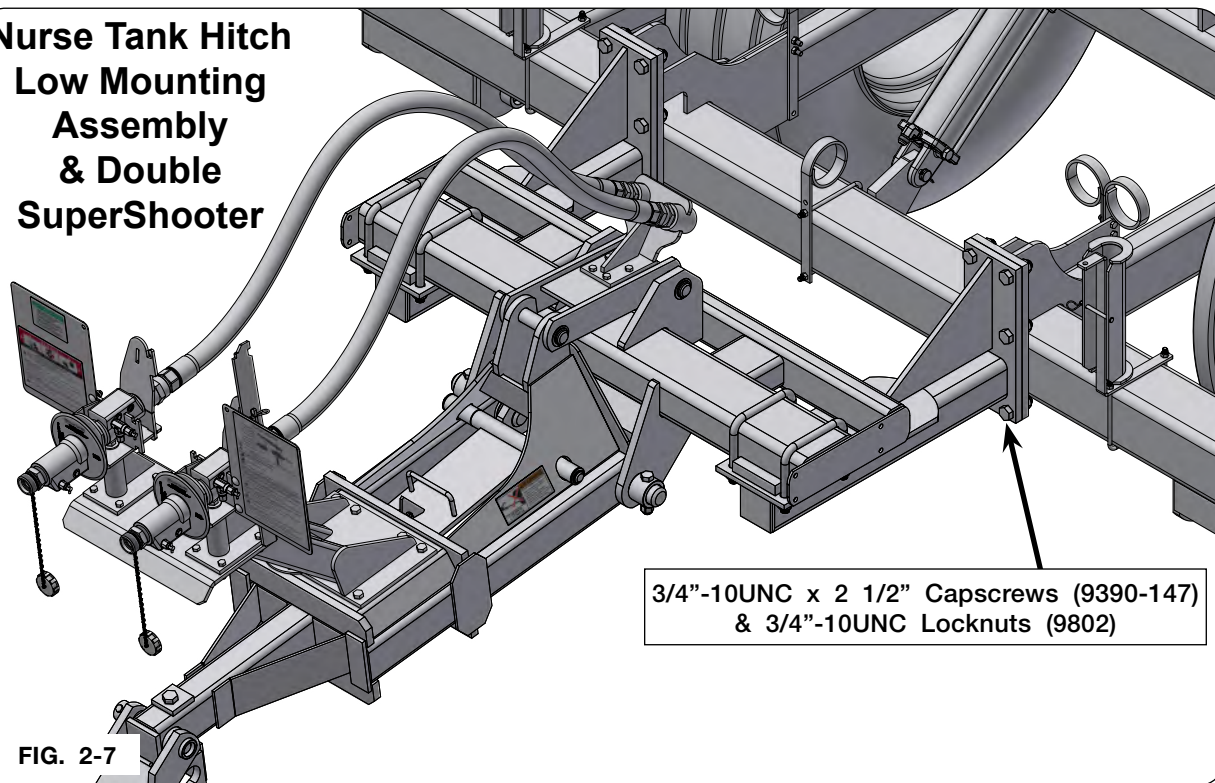

FIG. 2-7

Transport Lighting Assembly

Compliance with all lighting and marking laws is the responsibility of the operator at the time of travel.

See federal regulation 49 CFR 562; available at www.govinfo.gov for US federal law requirements.

See your Unverferth dealer for additional brackets, reflectors, or lights to meet your requirements.

NOTE: Refer to “OVERHEAD LAYOUTS” for nurse tank hitch light kit placement.

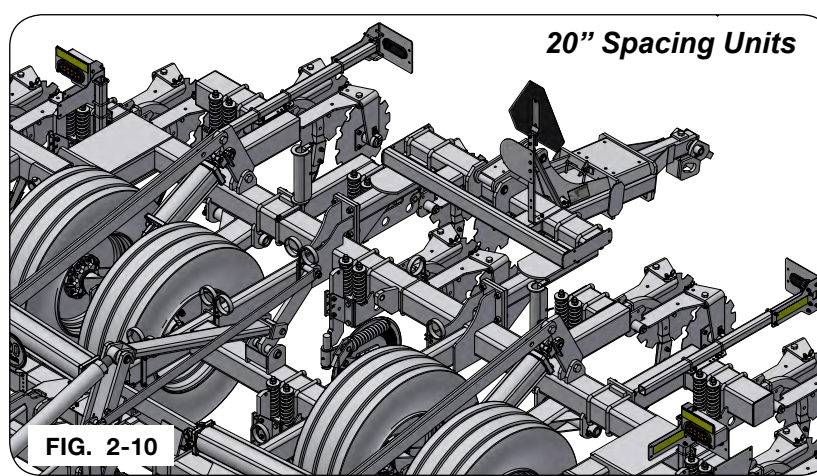
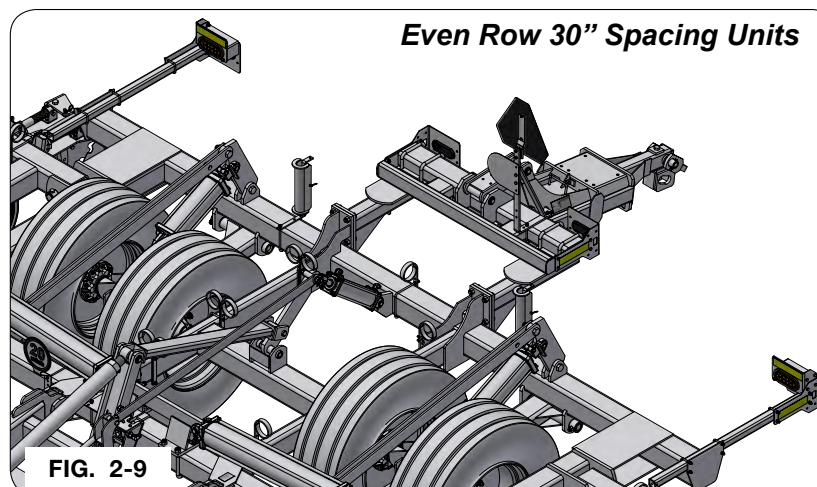
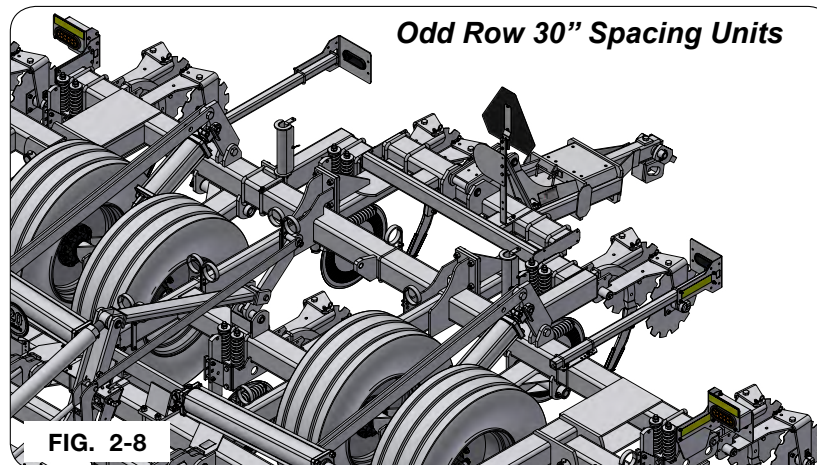

Transport Lighting Assembly (continued)

Lighting for 30" Spacing

1. Attach the light post mounting plate (JAM3408) with 3/8"-16UNC x 7" x 6 7/16" U-bolts (JBP3351) and 3/8"-16UNC elastic locknut (9398-012). (FIG. 2-11)
2. Place light bracket tube (JAM3416) on light post mounting plate (JAM3408). Secure tube with 3/8"-16UNC x 2" x 3" U-bolts (JBP3736) and 3/8"-16UNC elastic locknut (9398-012). (FIG. 2-11)

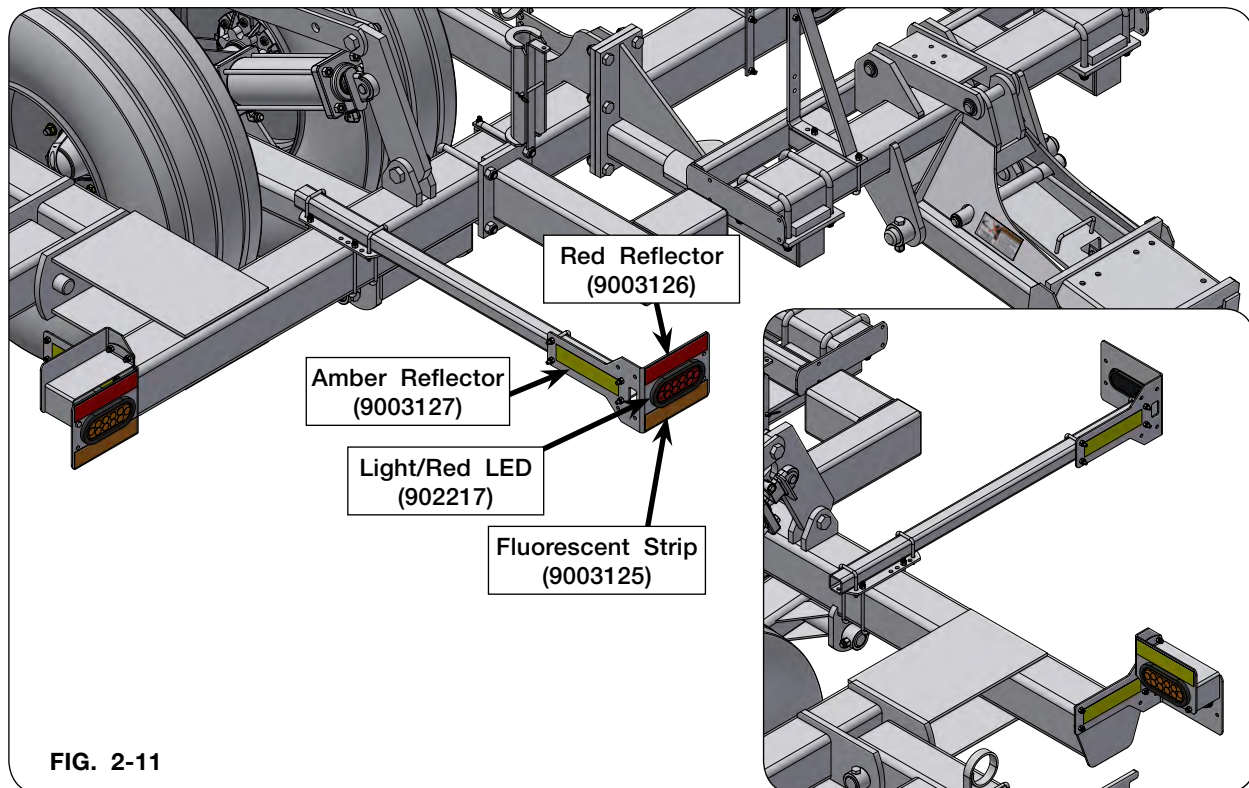

FIG. 2-11

3. Insert rear electrical wiring harness (JAP3222) into light bracket tube (JAM3416).
4. Install oval grommet (97182) into rear light bracket (JAM3414). Insert red oval tail light (902217). Attach rear electrical wiring harness (JAP3222) to red oval tail light (902217). (FIG. 2-11 & FIG. 2-12)
5. Attach rear light bracket (JAM3414) with 3/8"-16UNC x 2" x 3" U-bolts (JBP3736) and 3/8"-16UNC elastic locknut (9398-012). (FIG. 2-11)
6. Install yellow/amber reflector (9003127) to outside of rear light bracket (JAM3414). (FIG. 2-11)
7. Place orange decal (9003125) above red oval tail light (902217) and red reflector (9003126) below. (FIG. 2-11)

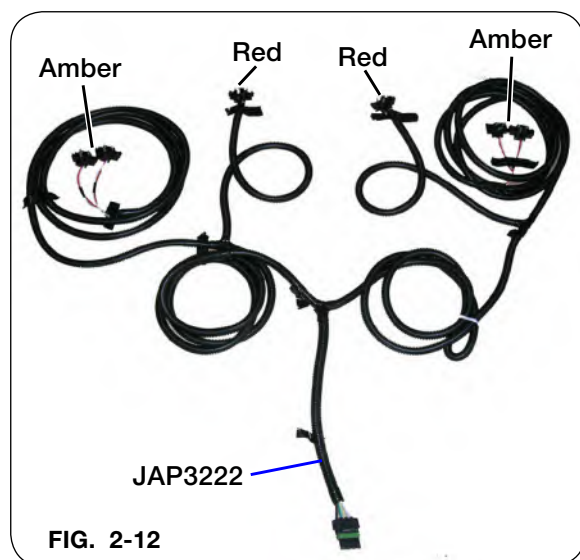
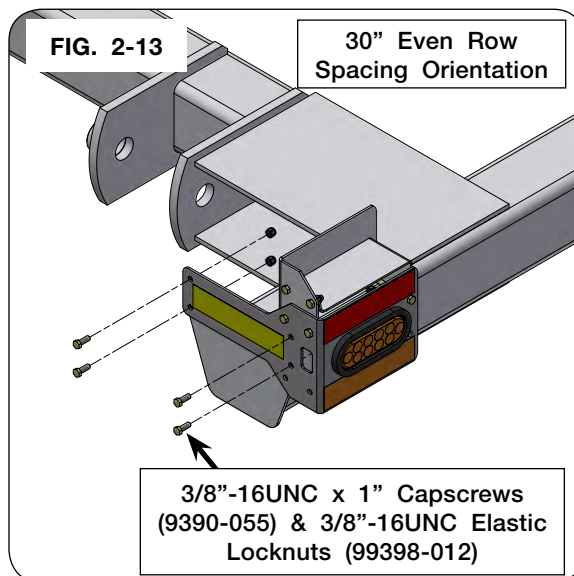

FIG. 2-12

Transport Lighting Assembly (continued)

Lighting for 30" Spacing

1. Mount rear light bracket (JAM3414) to frame side plate with 3/8"-16UNC x 1" capscrews (9390-055) and 3/8"-16UNC elastic locknut (9398-012). (FIG. 2-13)



NOTE: Orientation of rear light bracket (JAM3414) shown in FIG. 2-14 is for 30" odd row spacing. For 30" even row spacing, JAM3414 is flipped over so that the lights are to the inside of the frame (FIG. 2-13).

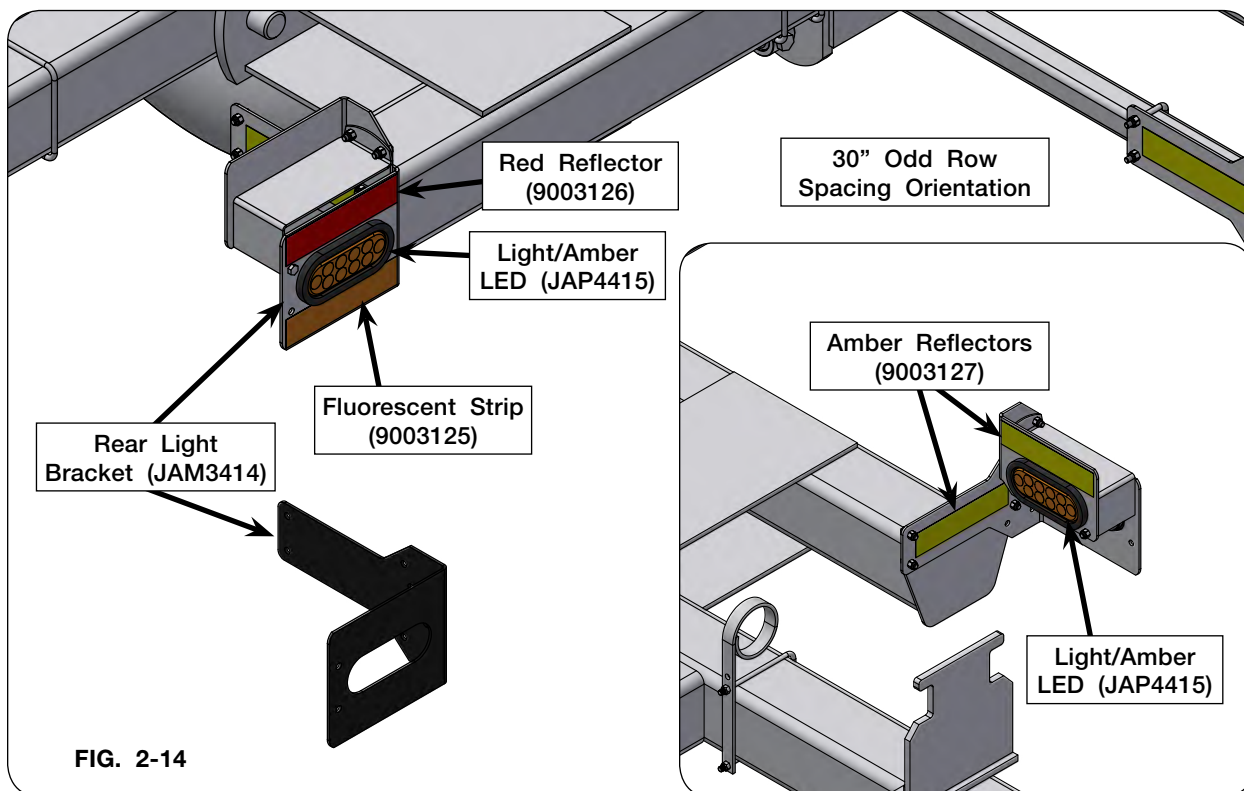

Transport Lighting Assembly (continued)

Lighting for All Spacings

1. Attach connector holder (9001968) to mounting bracket with 1/4"-20UNC x 3/4" flange screws (97420) and 1/4"-20UNC flange nuts (97189). (FIG. 2-16)
2. Extend rear electrical wiring harness (JAP3222) from lights to right-hand and left-hand sides across the rear of frame. (FIG. 2-15)
3. Attach electrical wiring harness extension (JAP3221) to rear electrical wiring harness (JAP3222). Extend down the right-hand side of the tongue through hose holders to dust cap. (FIG. 2-15)
4. Attach electrical wiring harness extension (JAP3221) to electrical plug and socket harness (JAP3223). (FIG. 2-15)

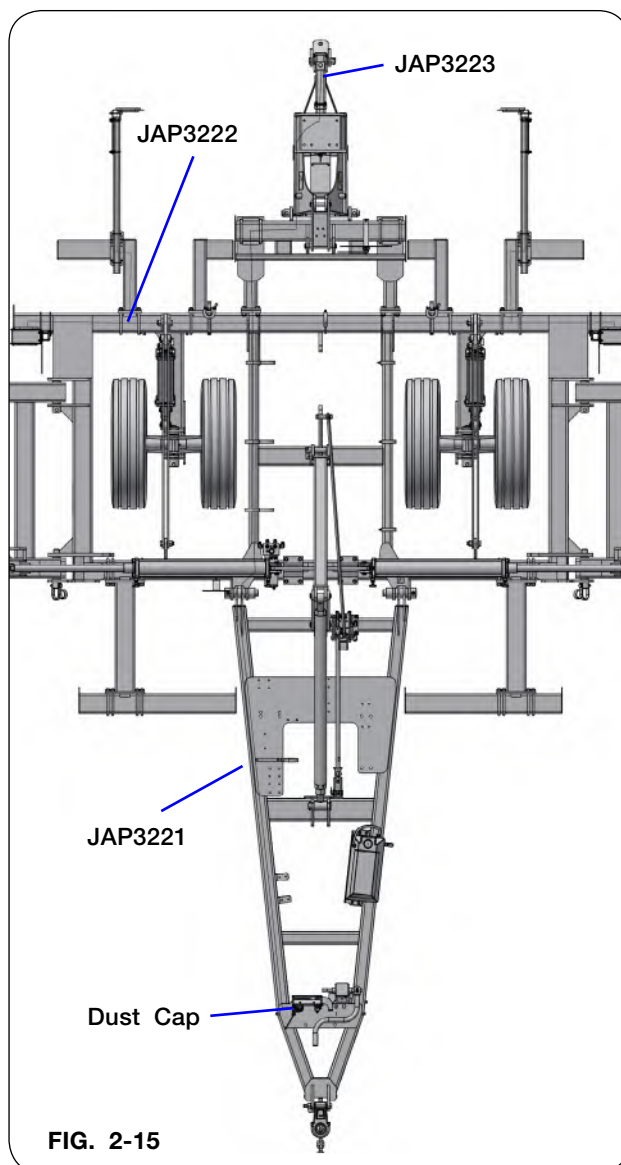
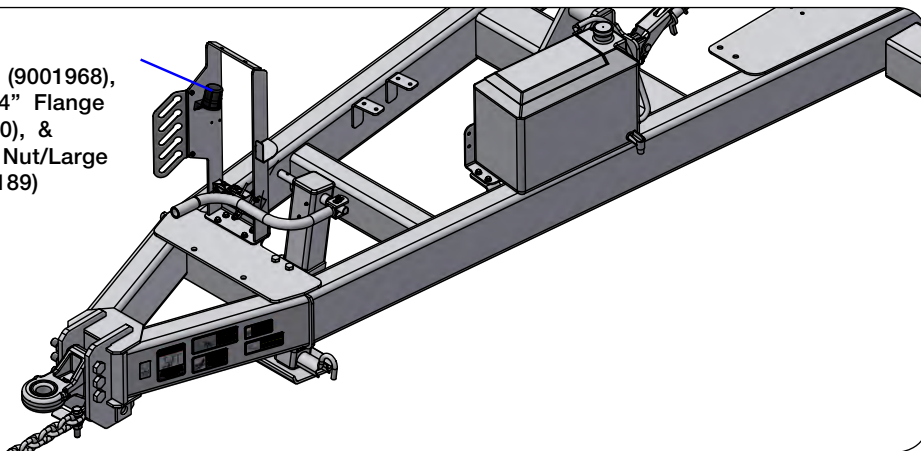

FIG. 2-15

FIG. 2-16

Connector Holder (9001968),
1/4"-20UNC x 3/4" Flange
Screw (97420), &
1/4"-20UNC Hex Nut/Large
Flange (97189)



SMV Assembly

1. Mount SMV mounting bracket (JAM3420) near the center of the rear bar with 3/8"-16UNC x 5" x 6 7/16" U-bolt (JBP3045) and 3/8"-16UNC elastic locknuts (9398-012). (FIG. 2-17)
2. Attach spade (TA510516) to SMV sign (TA510514) with hardware supplied. (FIG. 2-17)
3. Secure to socket (TA510515) with hardware provided. (FIG. 2-17 & FIG. 2-18)

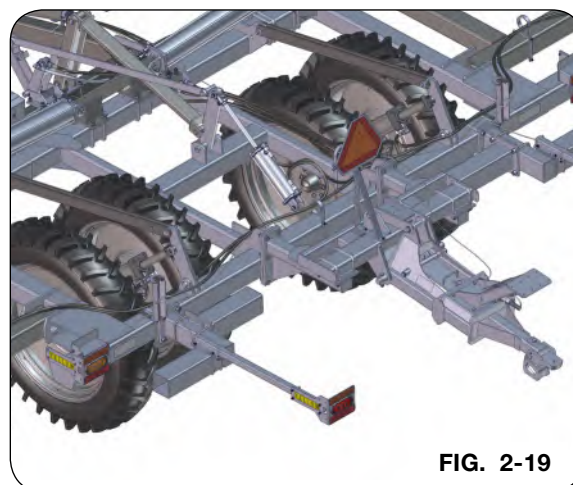
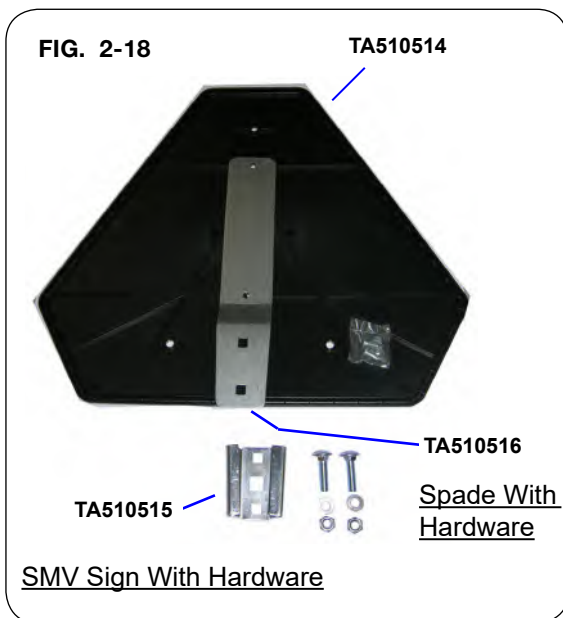
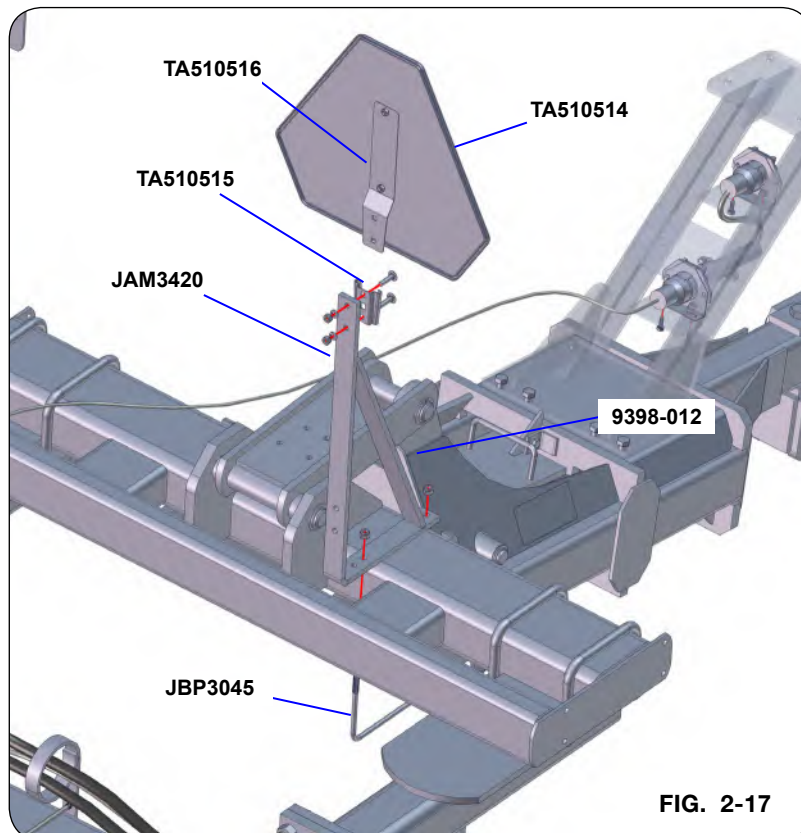

Mounting Offset Stagger & Double Extension Brackets

NOTE: For proper positioning, refer to “Overhead Layouts”, in SET UP section.

- Using a safe lifting device rated for at least 100 lbs., attach 6” x 6” mounting offset stagger brackets (JAM4545) with 3/4”-10UNC x 6”W x 7 1/16”L U-bolts (JBP3350) and 3/4”-10UNC hex nuts (9394-016). (FIG. 2-20 & FIG. 2-21)

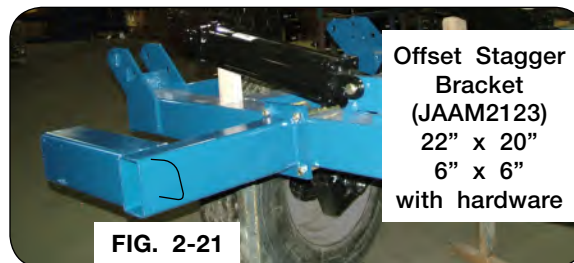
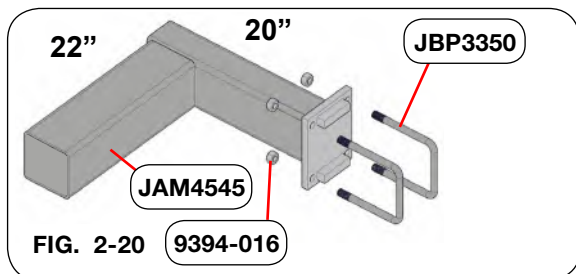

- Attach 35” double extension bracket (JAM6161) 6” x 6” mounting to frame with four 3/4”-10UNC x 6”W x 7 1/16”L u-bolts (JBP3350) and 3/4”-10UNC hex nuts (9394-016). (FIG. 2-22)
- Mount 35” extension bracket (JAM6160) to 35” double extension bracket (JAM6161) with four 3/4”-10UNC x 6”W x 7 1/16”L u-bolts (JBP3350) and 3/4”-10UNC hex nuts (9394-016). (FIG. 2-22)

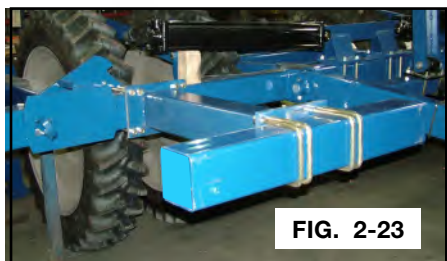
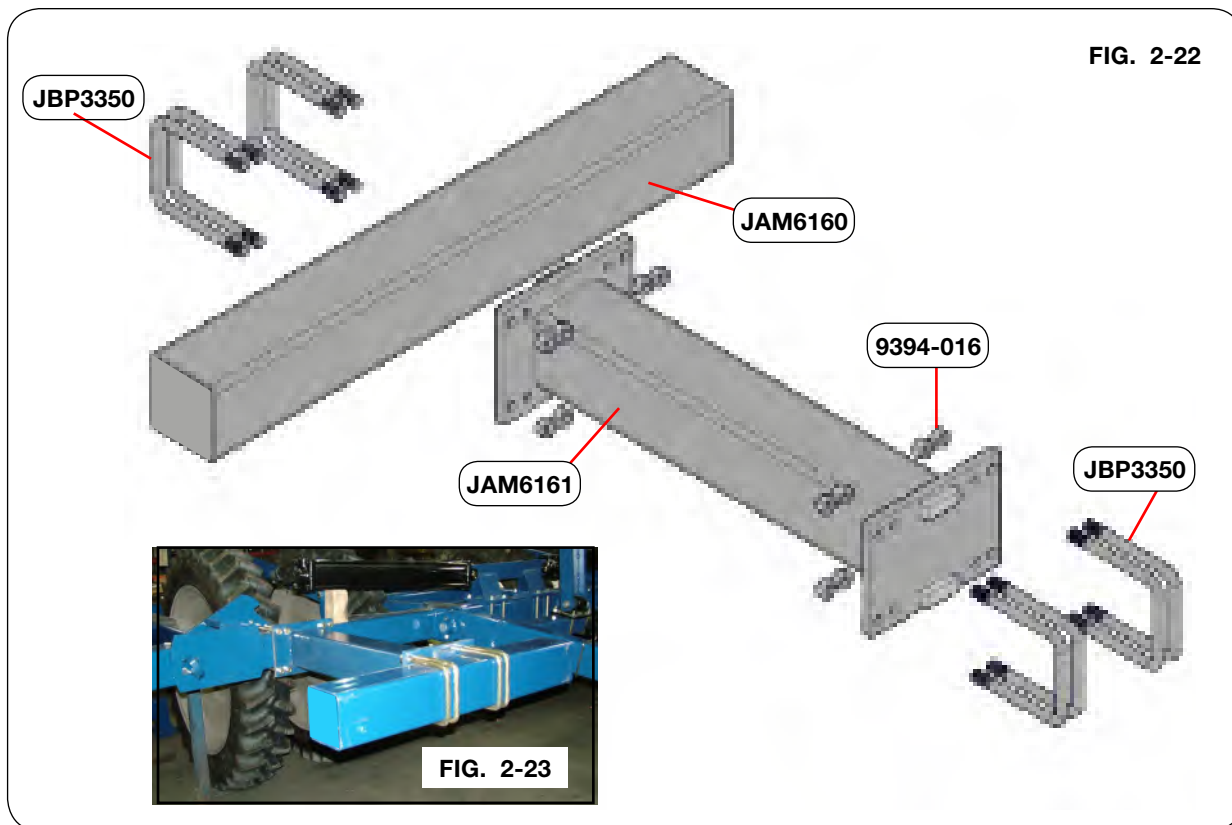

Sealer II Assembly (47615B)**Optional Sealer II Spring Add-On Kit (47616B)**

1. Remove the 1/2"-13UNC x 1 1/4" capscrews (9390-100) and 1/2"-13UNC locknuts (94981) from the lower clevis (JAM2489) (FIG. 2-24).
2. Mount the sealer spring lower clevis (JAM2489) to arm. Loosely attach with 1/2"-13UNC x 1 1/4" capscrews (9390-100) and 1/2"-13UNC locknuts (94981). (FIG. 2-24)
3. Remove the 1/2"-13UNC x 1 1/2" capscrews (9390-101) and 1/2"-13UNC locknuts (94981) from the upper weldment (FIG. 2-24).
4. Mount the upper weldment end of the sealer add-on kit to the sealer mounting bracket assembly with 1/2"-13UNC x 1 1/2" capscrews (9390-101) and 1/2"-13UNC locknuts (94981) (FIG. 2-24).
5. Secure hardware, but do not over tighten hardware. Allow tubes to pivot.

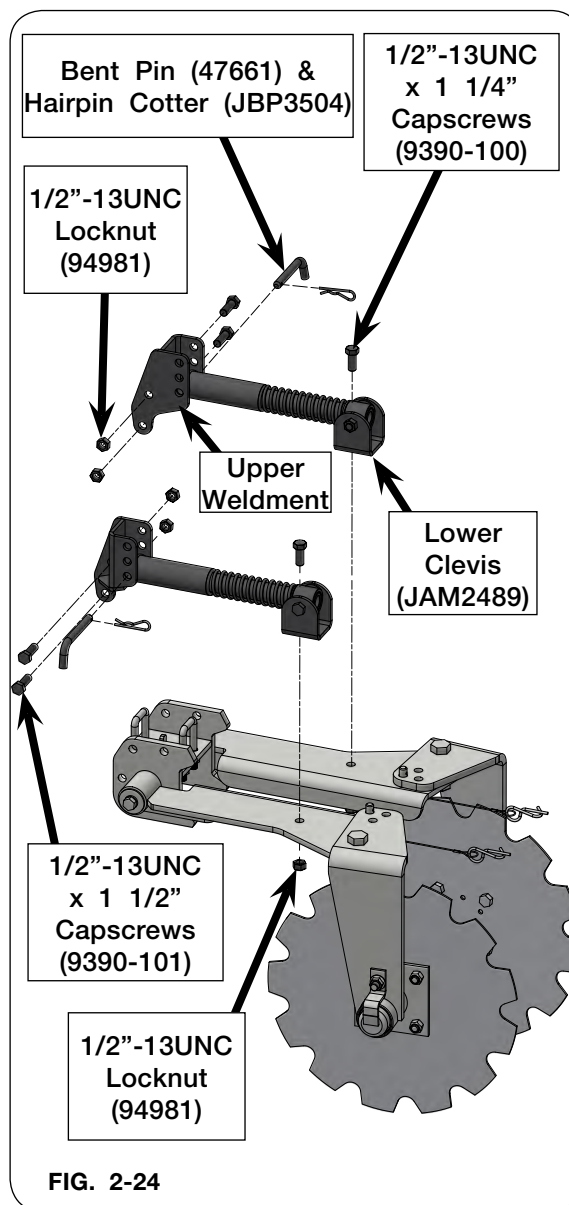

Torsion Arm Assembly

Attaching Bearings and Basket to Mounting Arms

- Loosely attach bearing (JAP2144) on strip-till basket mount arm (JAM2269), with 7/16"-14UNC x 1 1/2" capscrews (9390-080), 7/16" lock washers (9404-023), and 7/16"-14UNC hex nuts (9394-008). (FIG. 2-25)

NOTE: Do not tighten hex nuts until the basket is installed.

- Insert 1"-8UNC x 2 1/2" capscrew (9390-185) into both bearing arm assemblies (FIG. 2-25).

NOTE: Bearing lock collars not used.

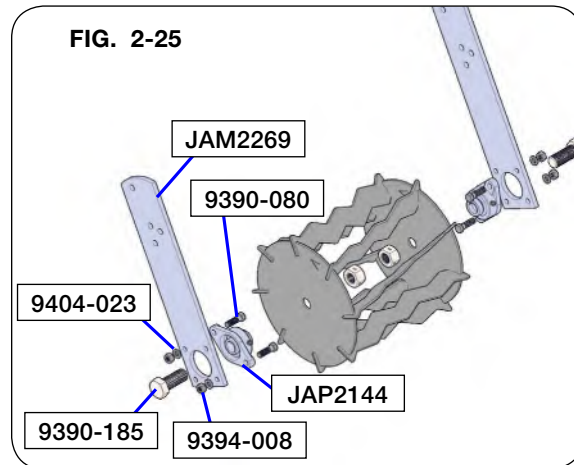

Position Basket on Torsion Spring Assembly

- Insert strip-till basket (JAM7615), over 1"-8UNC x 2 1/2" capscrew (9390-185) (FIG. 2-27). Install 1"-8UNC locknut (92199). Tighten hardware according to Torque Chart in MAINTENANCE section.

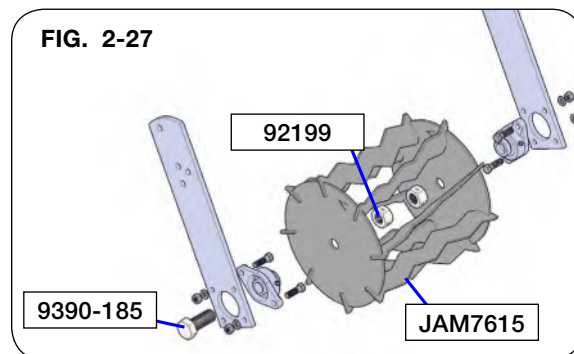
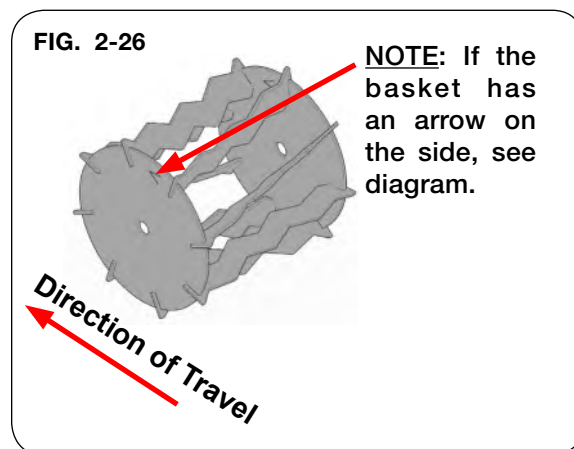

Torsion Arm Assembly (continued)

Center Basket

1. Position StripTill basket assembly on torsion spring assembly (FIG. 2-28). Insert 1/2"-13UNC x 1 1/2" capscrews (9390-101), top and bottom. Secure top pivot hex cap screws with 1/2" locknuts (94981). Secure lower adjustable capscrews with 1/2" lock washers (9404-025) and 1/2"-13UNC hex nuts (9394-010). Tighten hardware according to Torque Chart in MAINTENANCE section.

NOTE: Insert the basket arms to the inside of the StripTill torsion spring (JAM7568).

(Diagram shows a starting/medium packing position.)

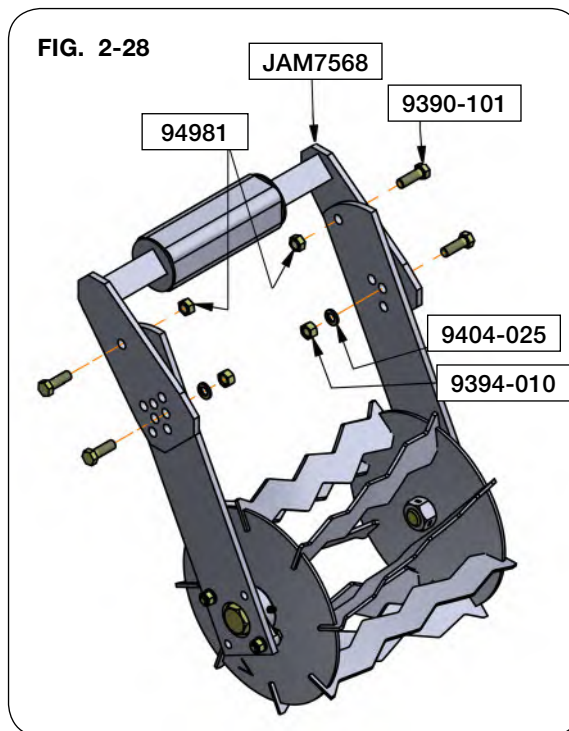

Attaching Torsion Arm Assembly To MaxPac Basket Mount Arm

1. Attach torsion arm assembly (J70210641), to MaxPac basket mount arm with 5/8"-11UNC x 2 1/2" x 4" U-bolts (JBP3300) and 5/8"-11UNC locknuts (9801) (FIG. 2-29).

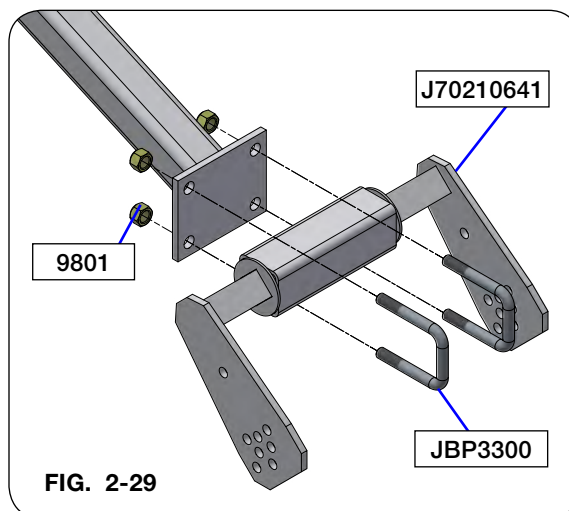

Torsion Arm Assembly (continued)

**Attaching Torsion Arm Assembly To 6"x6" Tube
(Bundle #JAAM2630)**

1. Center and attach torsion arm assembly (J70210641), to the basket mount plate (JAM7637) with 5/8"-11UNC x 2 1/2"W x 4"L U-bolts (JBP3300) and 5/8"-11UNC locknuts (9801) as shown below. Tighten hardware according to Torque Chart in MAINTENANCE section.

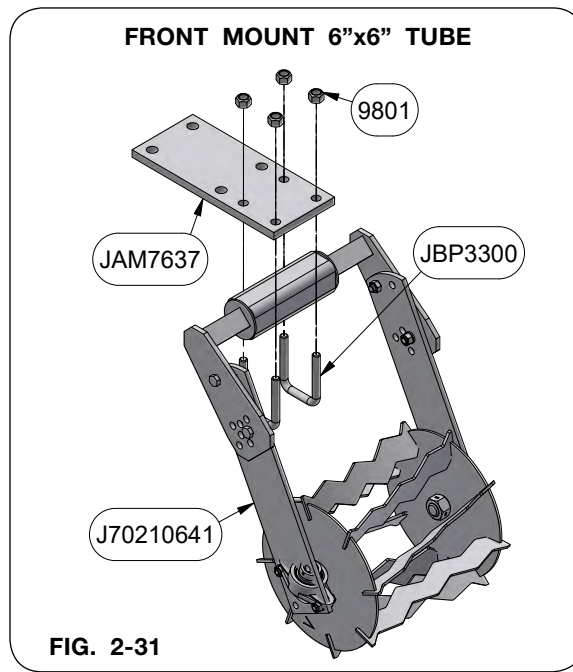
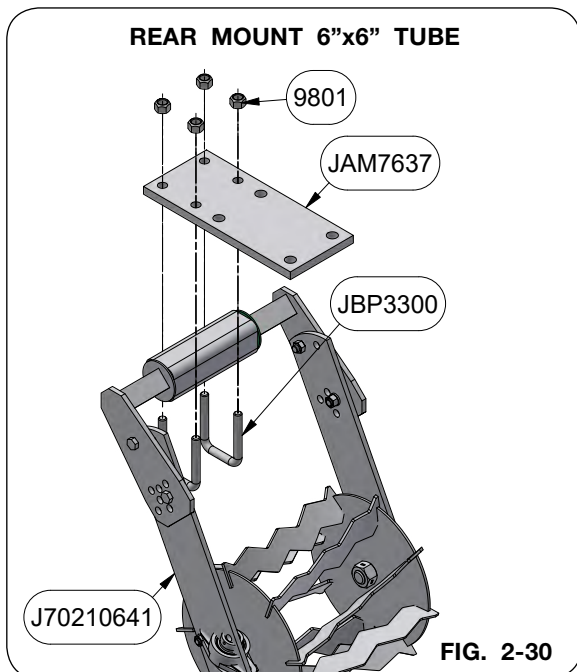

2. Using a safe lifting device rated at a minimum of 100 lbs., secure the basket mount plate to the rear or front mount 6"x6" tube with two 3/4"-10UNC x 6"W x 7 11/16"L U-bolts (JBP3350) and four 3/4"-10UNC locknuts (9802). Torque hardware.

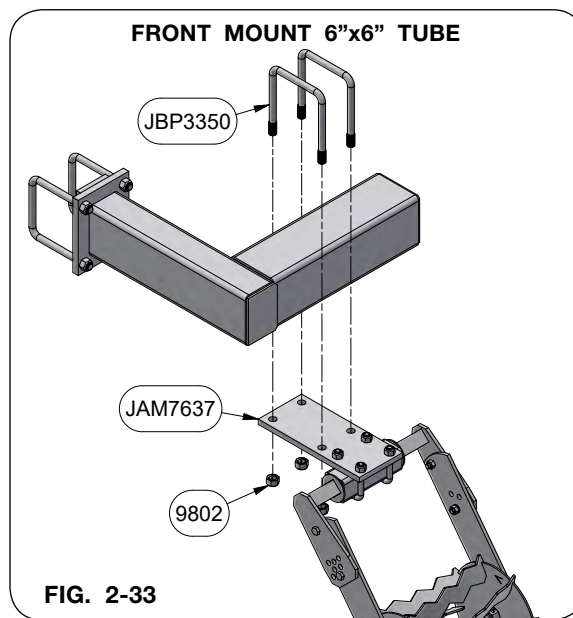
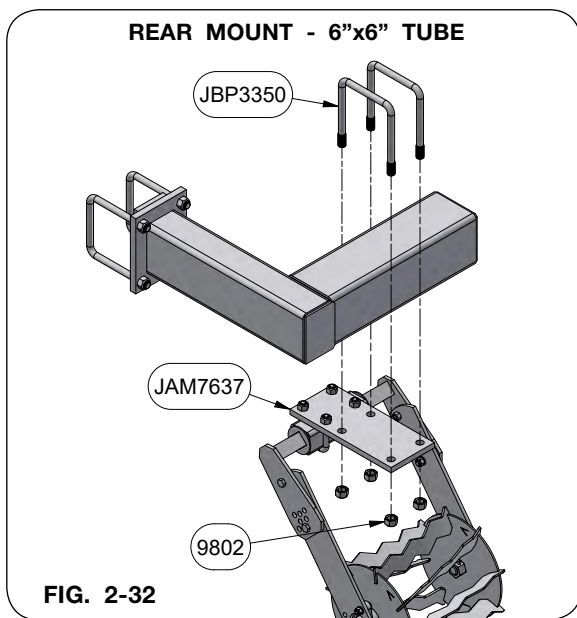

MaxPac AR700 Assembly

1. Using a safe lifting device rated at a minimum of 150 lbs., secure MaxPac row unit (JAM2264) with 1 1/4" x 2" EdgeBent shank (JAP2125) with backing plate (JAM2262), 3/4"-10UNC x 8" capscrews (9390-161) and 3/4"-10UNC locknuts (9802). (FIG. 2-34)

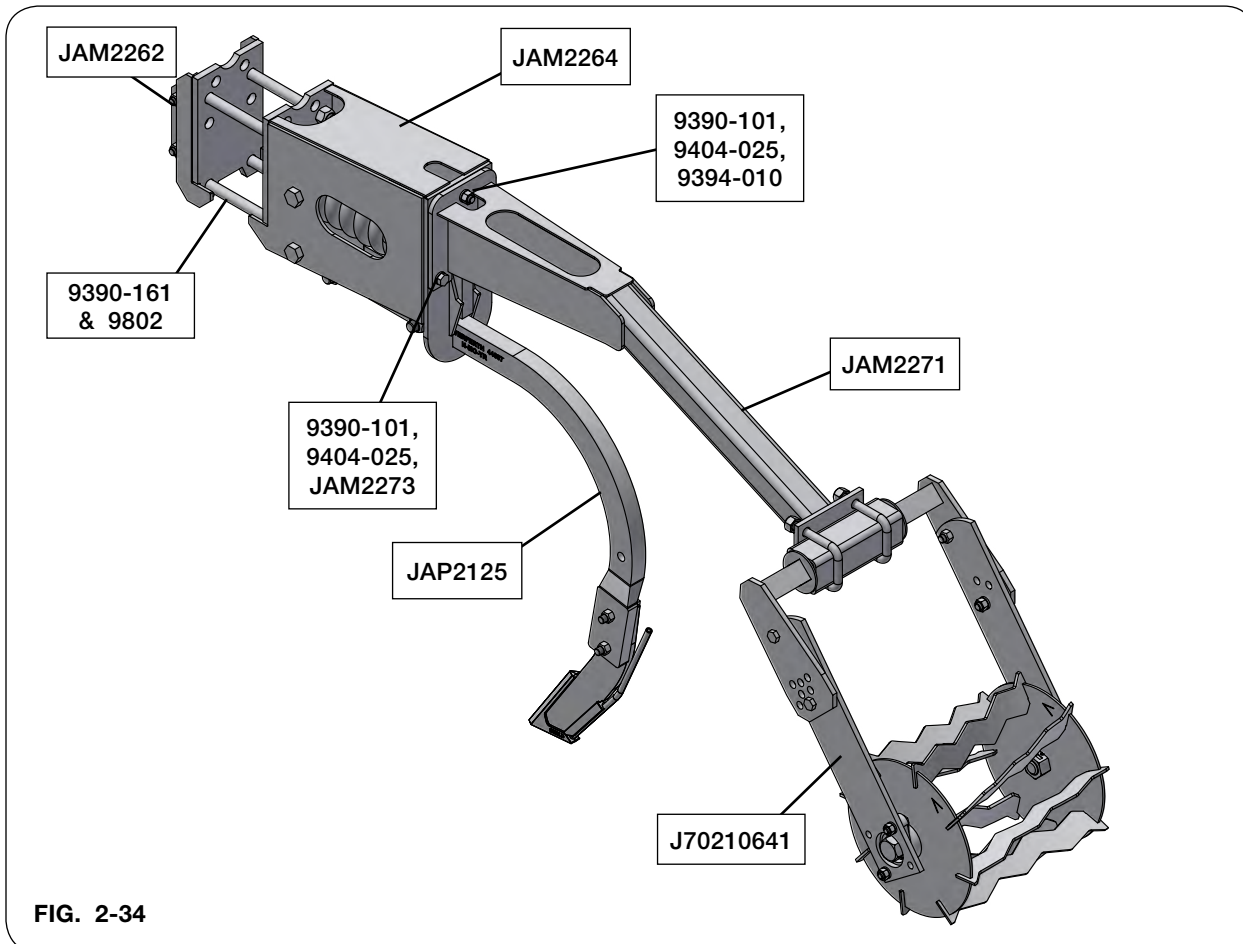
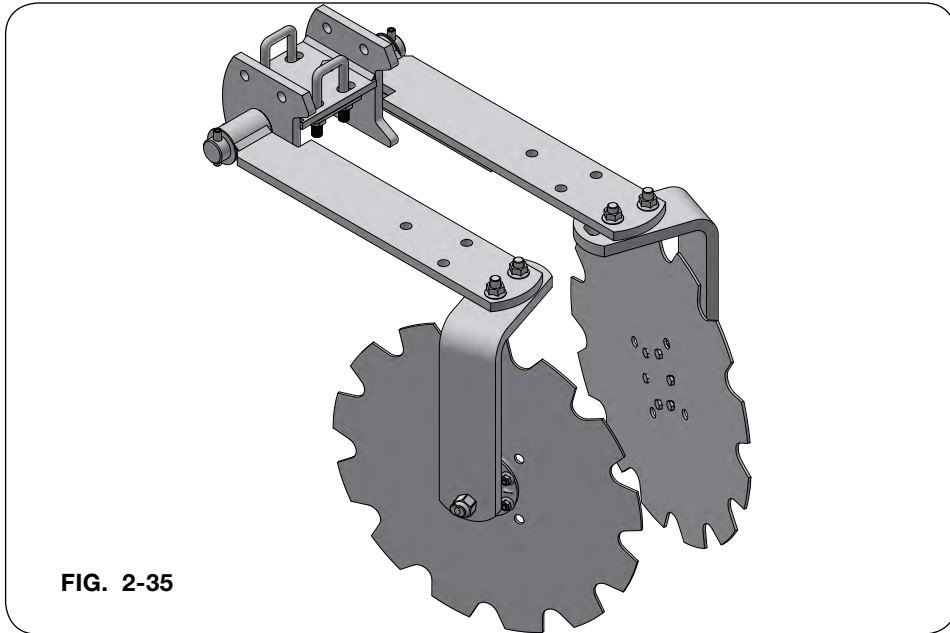

FIG. 2-34

2. Using a safe lifting device rated at a minimum of 100 lbs., secure MaxPac basket mount weldment (JAM2271) and torsion arm assembly (J70210641) to the MaxPac row unit (JAM2264) with two nut plate weldments (JAM2273), one 1/2"-13UNC hex nut (9394-010), three 1/2" lock washers (9404-025), and three 1/2"-13UNC x 1 1/2" capscrews (9390-101). (FIG. 2-34)
3. Tighten hardware according to Torque Chart in the MAINTENANCE section of this manual.

DiscCover Sealer Assembly

Refer to DiscCover Sealer manual for specific Set Up instructions.



Setting The Implement For Field Operation

1. Run the implement in the field for approximately 100 feet (making sure the tractor reaches the speed at which you wish to operate the machine). Stop while leaving the shanks in the ground.
2. Check for your desired shank depth on a middle row and on each wing. Shank depth should be at least 4" from ground level (6"-8" is optimum fertilizer placement depth for corn in most areas). Adjust the mainframe and wing wheels accordingly and repeat steps 1&2 until desired depth across the machine is achieved.
3. Ensure the frame is level from front to back when the shanks are in the ground at the depth you have chosen.
4. Walk to the back of the machine
 - a. Check for uniformity on the strips from row to row. Below: are items to look for.
 - i. **Fall Operation (In areas with a good freeze-thaw over the winter):**
 1. Top of the berm should be at a minimum height of 4" from ground level (expect it to mellow 2"-3" over the winter)
 2. Berm should be 8"-10" wide
 3. There should be little to no residue within the strip (if using Residue Managers)
 4. The top of the berm should be slightly flattened and most dirt clods should be no larger than your fist (if using baskets on a light setting).
 - ii. **Fall Operation (In areas with little to no freeze-thaw over the winter):**
 1. Top of the berm should be at a height of 2"-3" from ground level (expect it to mellow 1"-2" with winter moisture)
 2. Berm should be 8"-10" wide
 3. There should be little to no residue within the strip (if using Residue Managers)
 4. The top of the berm should be moderately flat and most dirt clods should be no larger than a golf ball (if using baskets on a medium setting)
 - iii. **Spring Operation (all areas)**
 1. Top of the berm should be at a height of 1"-2" from ground level
 2. The berm should be 8"-10" wide
 3. There should be little to no residue within the strip (if using Residue Managers)
 4. The top of the berm should be flat and soil should have a finished look, ready for planting.
 - b. If you see uniformity in the strips across each row, and they are as described above based on the season and climate in which you are running, you are ready to proceed with normal operation.

Setting The Implement For Field Operation (continued)

5. If you do not see uniformity in the strips from row to row, pick one of the strips that looks like the description above and use it as an example row. Set the components on the other rows similar to your example row. Below are some of the component settings to check.
 - a. **Coulters**
 - i. Look across the tops of the coulter shanks to see if they are set at equal depth.
 1. Blades should be running 3"-4" in the ground
 2. Be sure the coulter is not set so deep that the hub is running in the ground
 - ii. If the implement has been used before, check the coulter blades to make sure they have similar wear/diameters.
 - b. **Sealer Blade Hanger Position**
 - i. Check to make sure all sealer blade hanger brackets are mounted on the sealer arms in the same positions (all front, all back, or all offset)
 - ii. Check to make sure all sealer blade hanger brackets are mounted on the same width position (either all narrow or all wide)
 - iii. See recommended setting for your residue type and climate above
 - c. **Sealer Blade Angle**
 - i. Check to see that the blades on each row are set at a similar angle
 - ii. Check to see that the backs of the blades on each row are set approximately the same distance apart.
 - iii. See recommended settings for your residue type and climate above
 - d. **Baskets**
 - i. Check to see that all baskets are running on the same pressure setting.
 - ii. Ensure that all baskets freely spin and some are not significantly more restricted compared to others.
 - iii. See recommended setting for your residue type and climate above
 - e. **Knives**
 - i. Lift the implement out of the ground and ensure knives are identical in make and model
 - ii. If the implement has been used before, check to make sure wear characteristics on the knives are similar.
6. If you have checked all settings and still do not see uniformity across the rows, or you have tried different settings and cannot achieve a strip like those described above, call your dealer for additional assistance.

6120 - Toolbars

**Generic Image For
Toolbars 48' & Under**

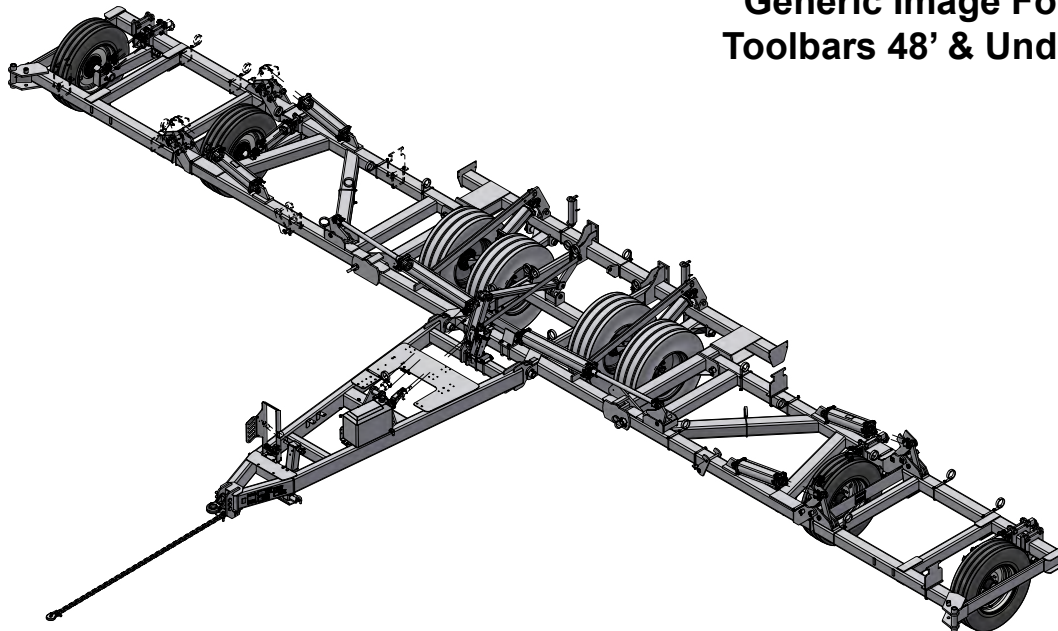

**Generic Image For
Toolbars Over 48'**

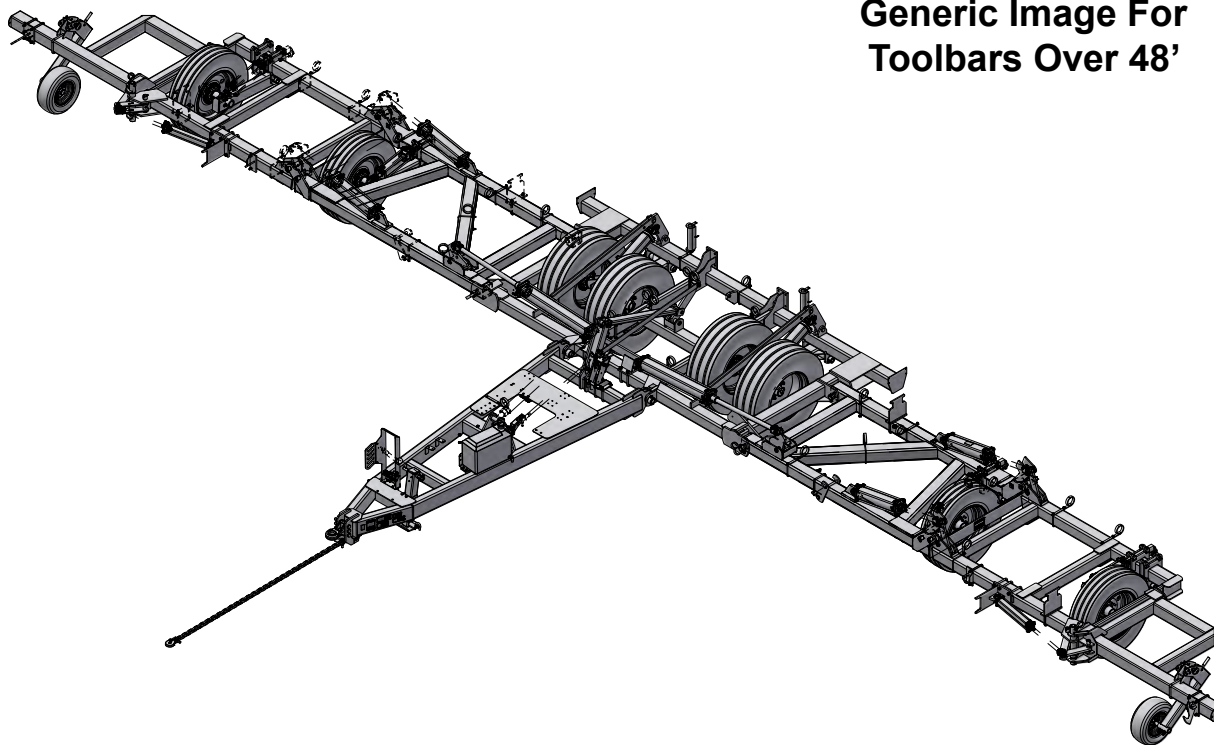

Overhead Layout - 6120 - 18 Row 30" Spacing

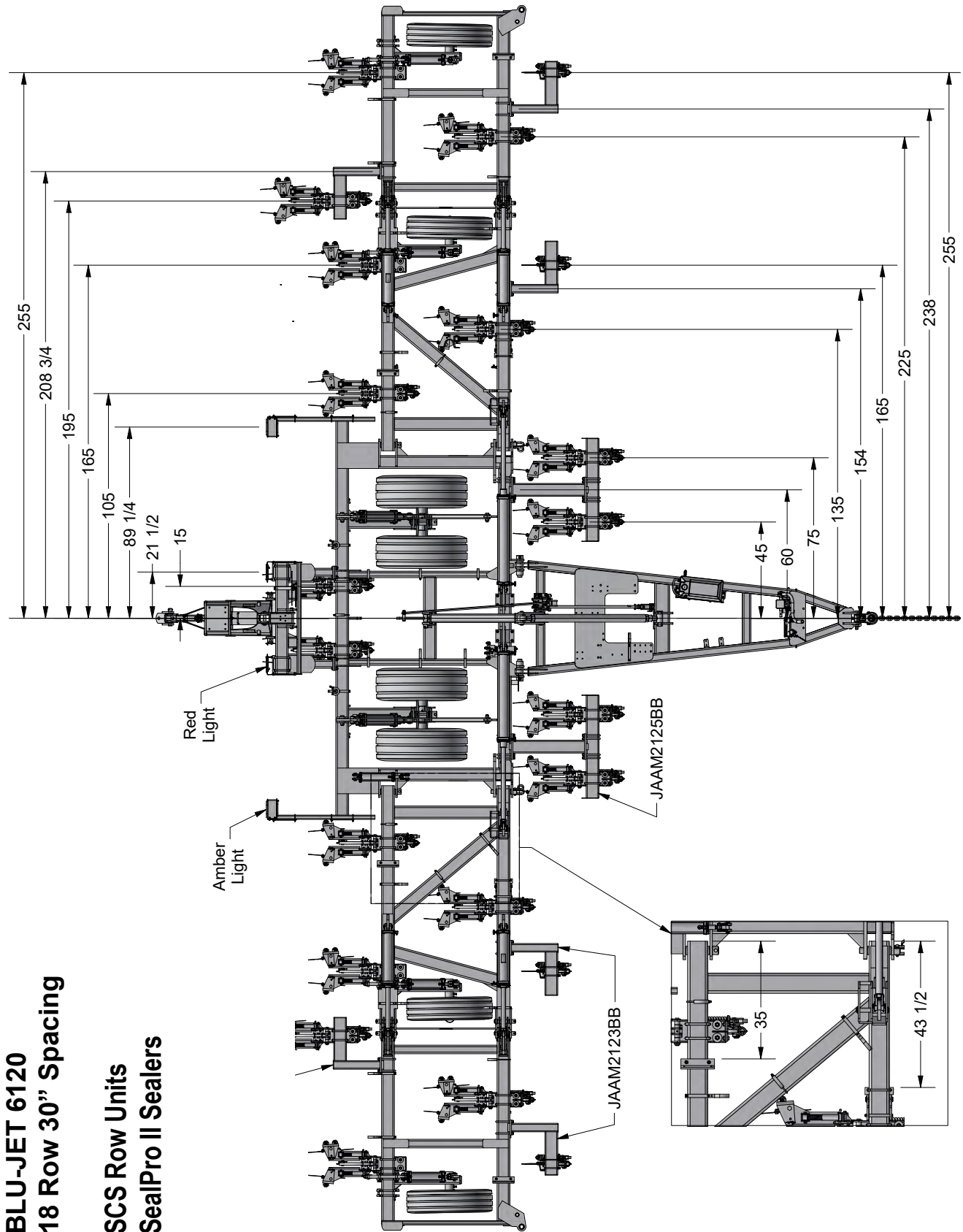

Overhead Layout - 6120 - 19 Row 30" Spacing

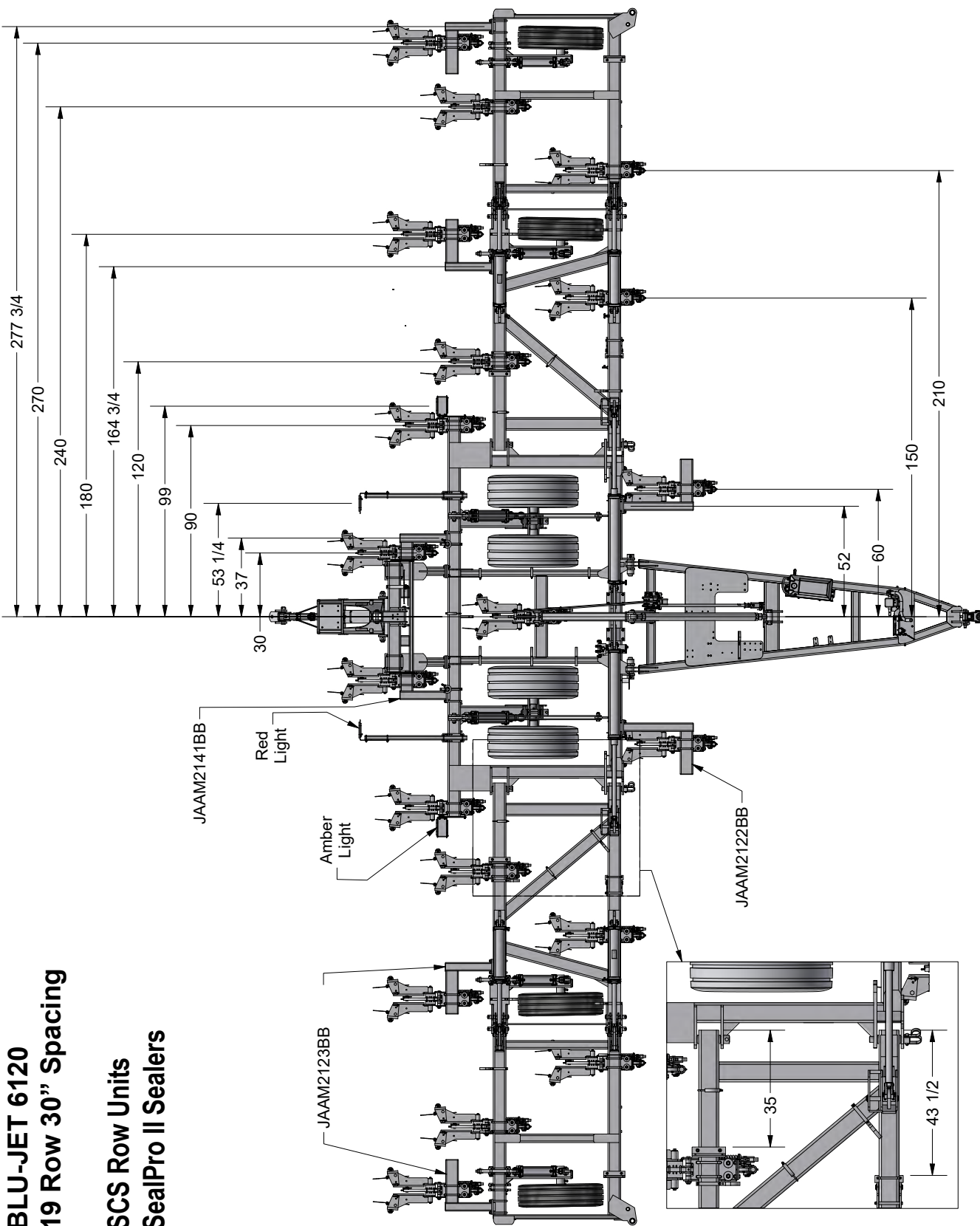

BLU-JET 6120
19 Row 30" Spacing

SCS Row Units
SealPro II Sealers

Overhead Layout - 6120 - 19 Row 30" Spacing

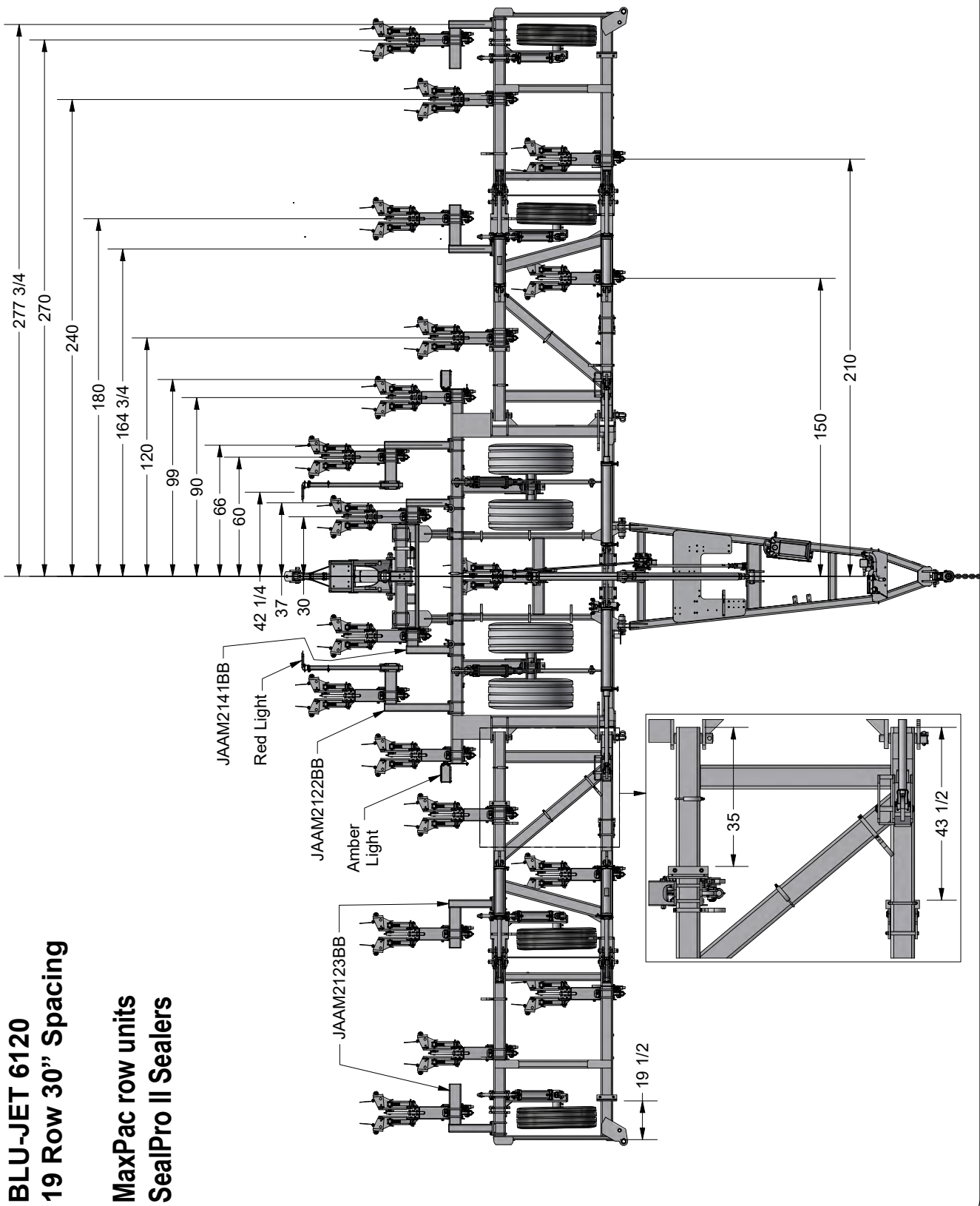

BLU-JET 6120
19 Row 30" Spacing

MaxPac row units
SealPro II Sealers

Overhead Layout - 6120 - 23 Row 30" Spacing

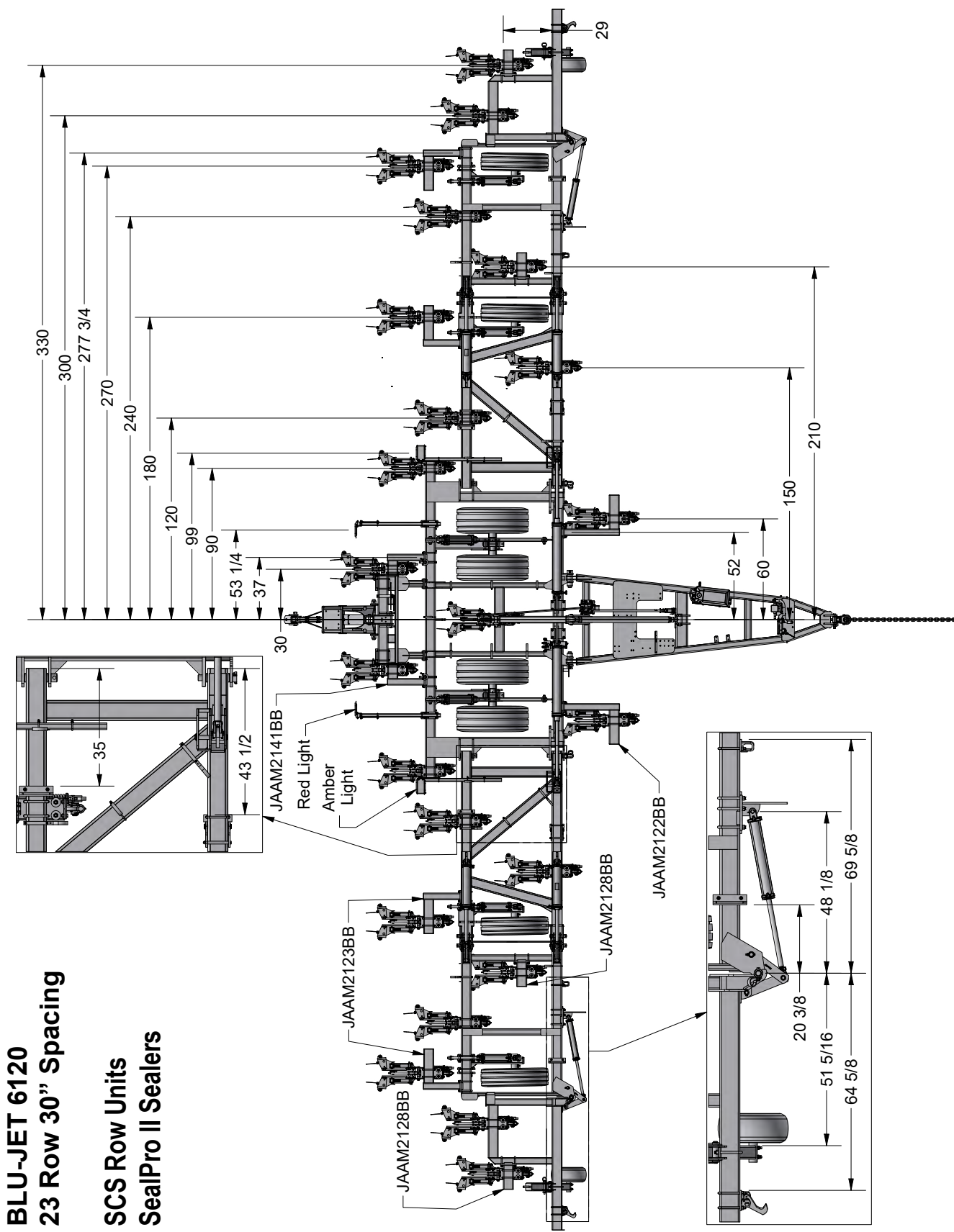

BLU-JET 6120
23 Row 30" Spacing

SCS Row Units
SealPro II Sealers

Overhead Layout - 6120 - 23 Row 30" Spacing

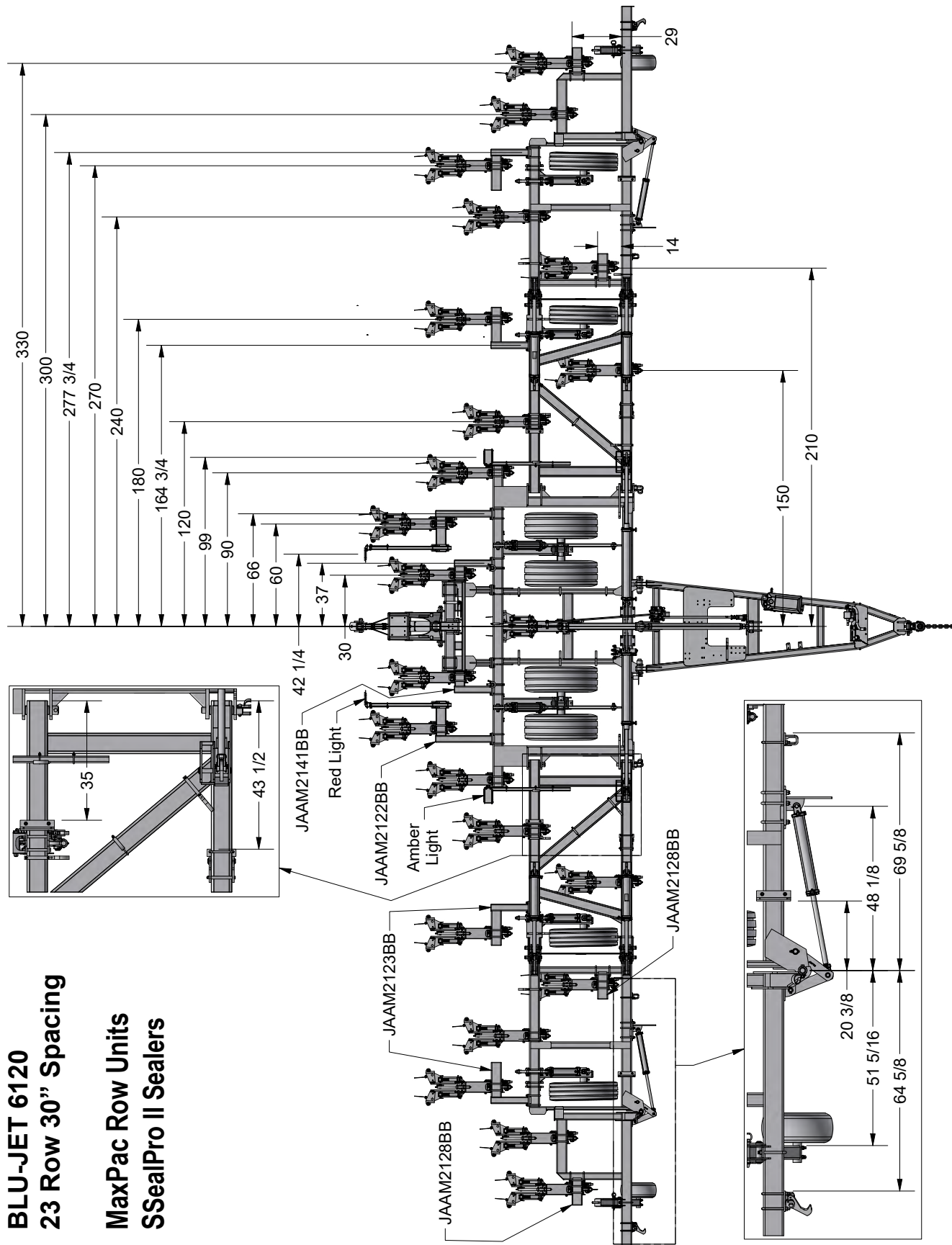

BLU-JET 6120
23 Row 30" Spacing
MaxPac Row Units
SSealPro II Sealers

Overhead Layout - 6120 - 24 Row 30" Spacing

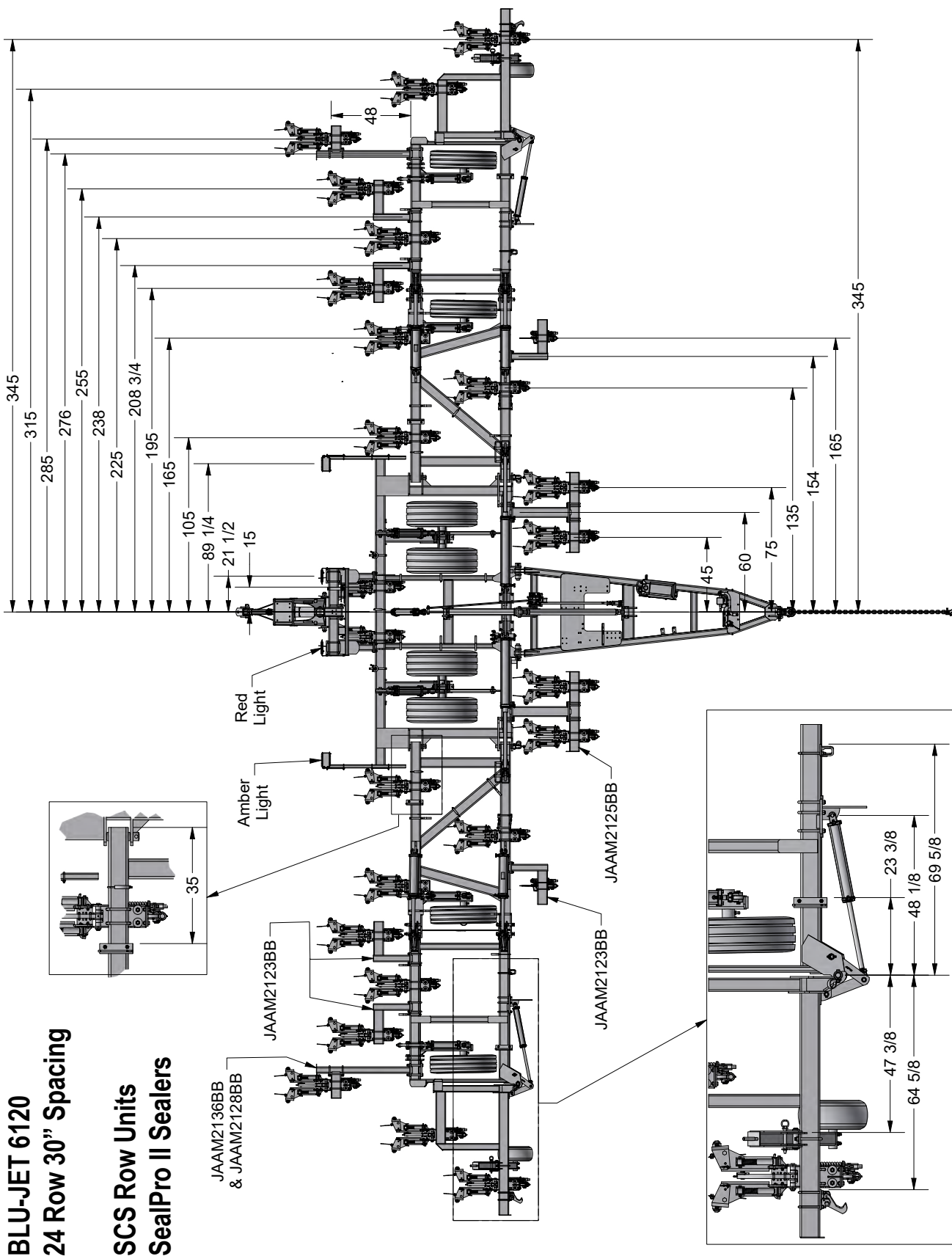

BLU-JET 6120
24 Row 30" Spacing

SCS Row Units
SealPro II Sealers

Overhead Layout - 6120 - 24 Row 30" Spacing

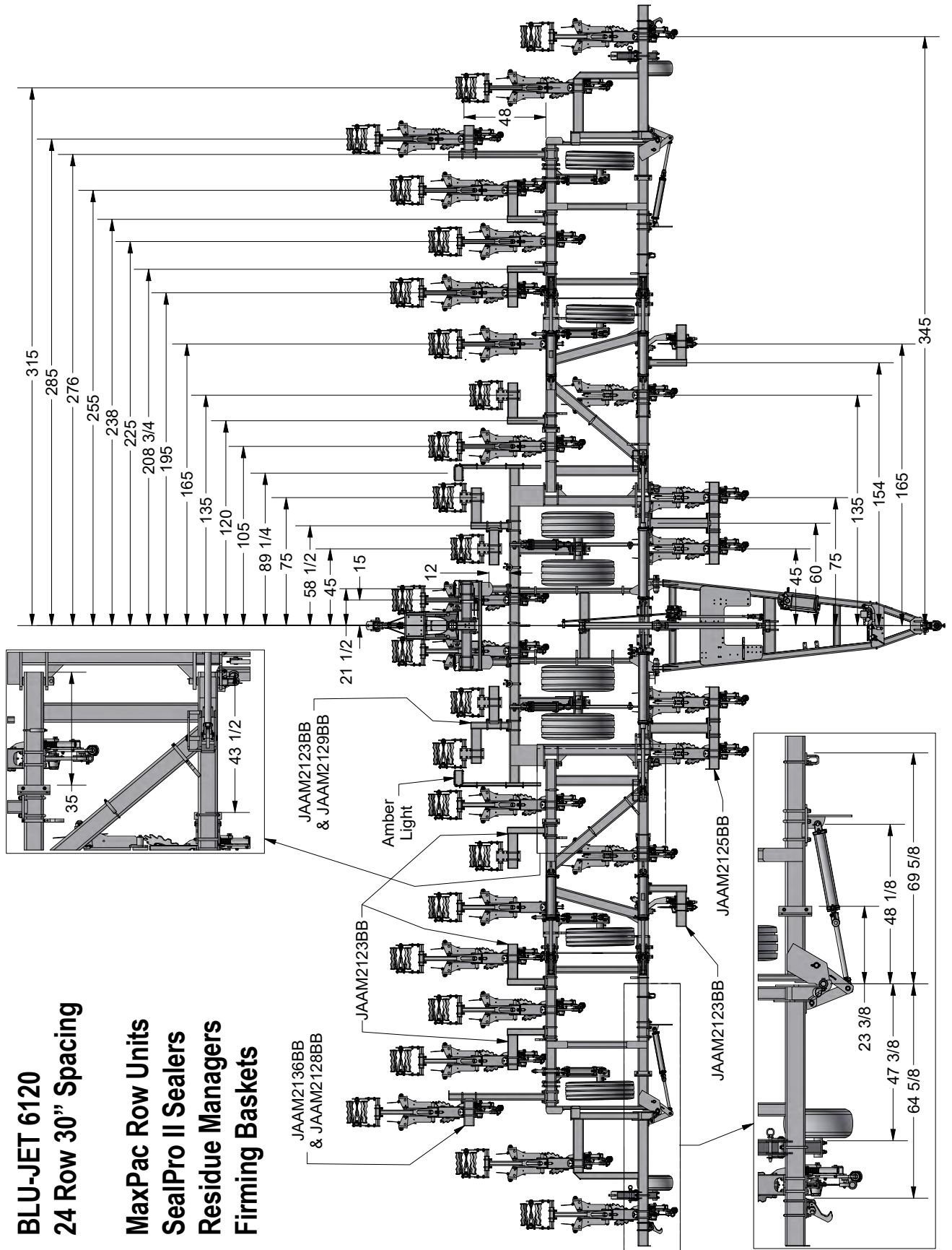

BLU-JET 6120
24 Row 30" Spacing

MaxPac Row Units
SealPro II Sealers
Residue Managers
Firming Baskets

Overhead Layout - 6120 - 25 Row 30" Spacing

BLU-JET 6120
25 Row 30" Spacing
SCS Row Units
SealPro II Sealers

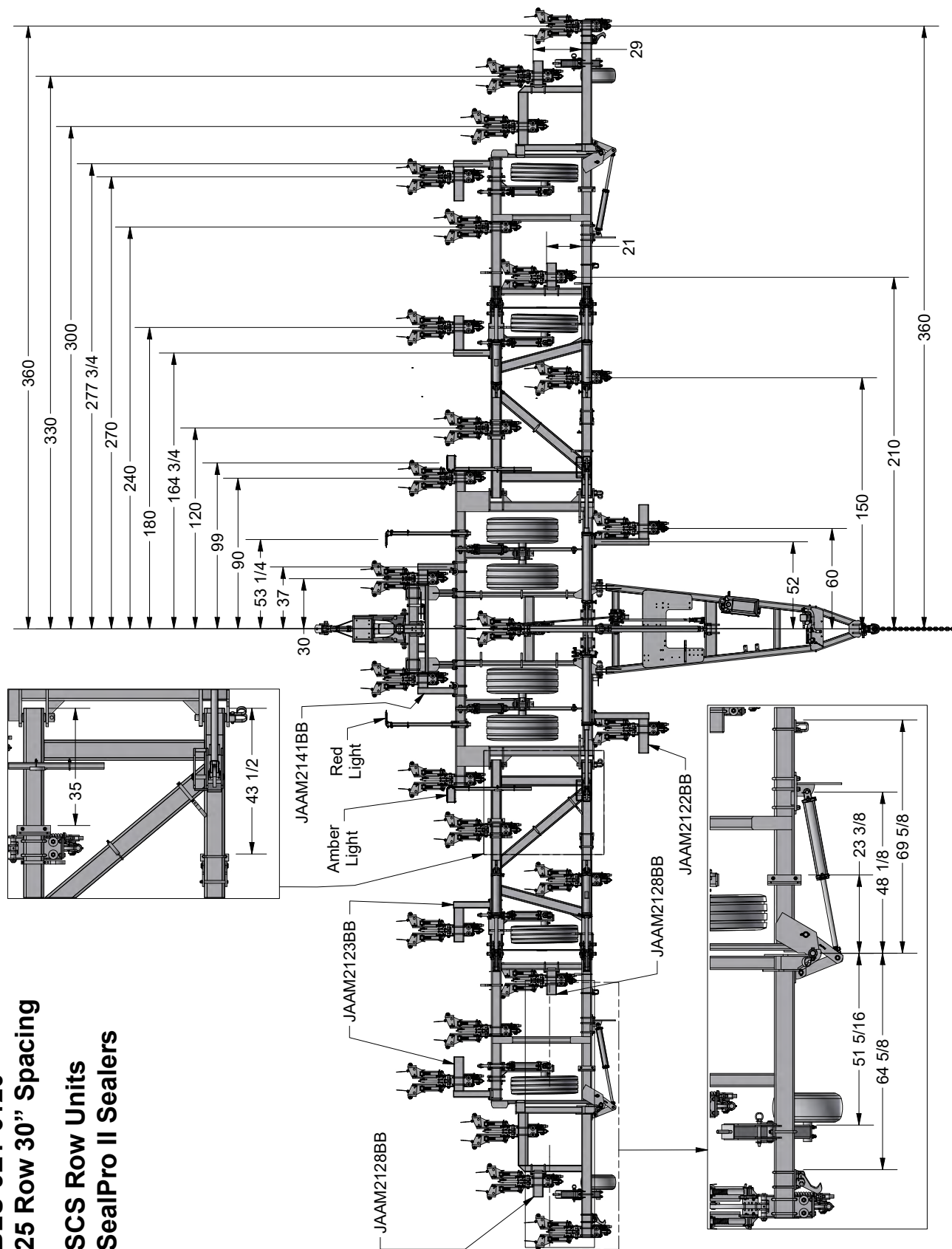

Overhead Layout - 6120 - 25 Row 30" Spacing

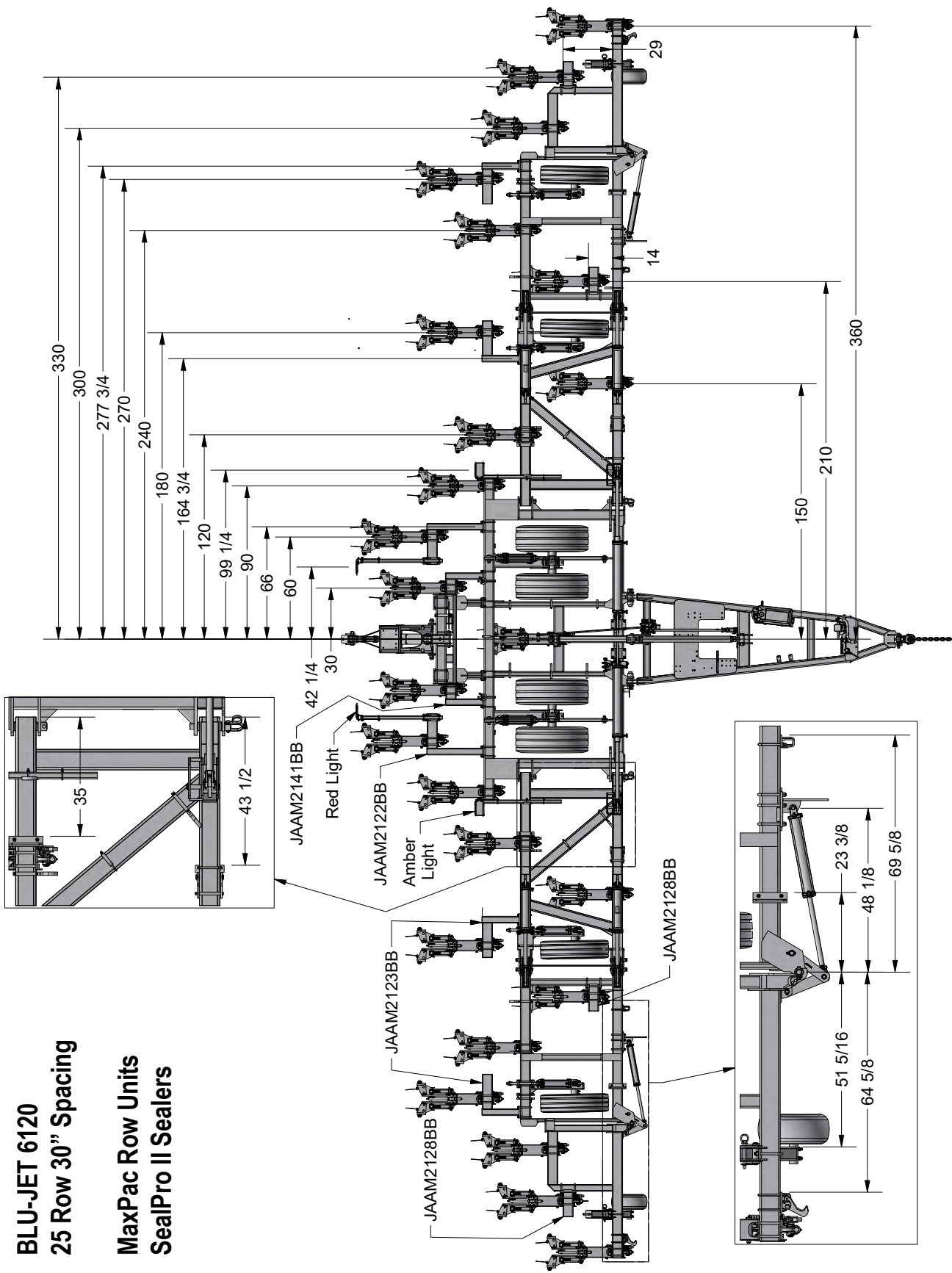

BLU-JET 6120
25 Row 30" Spacing
MaxPac Row Units
SealPro II Sealers

Overhead Layout - 6120 - 28 Row 20" Spacing

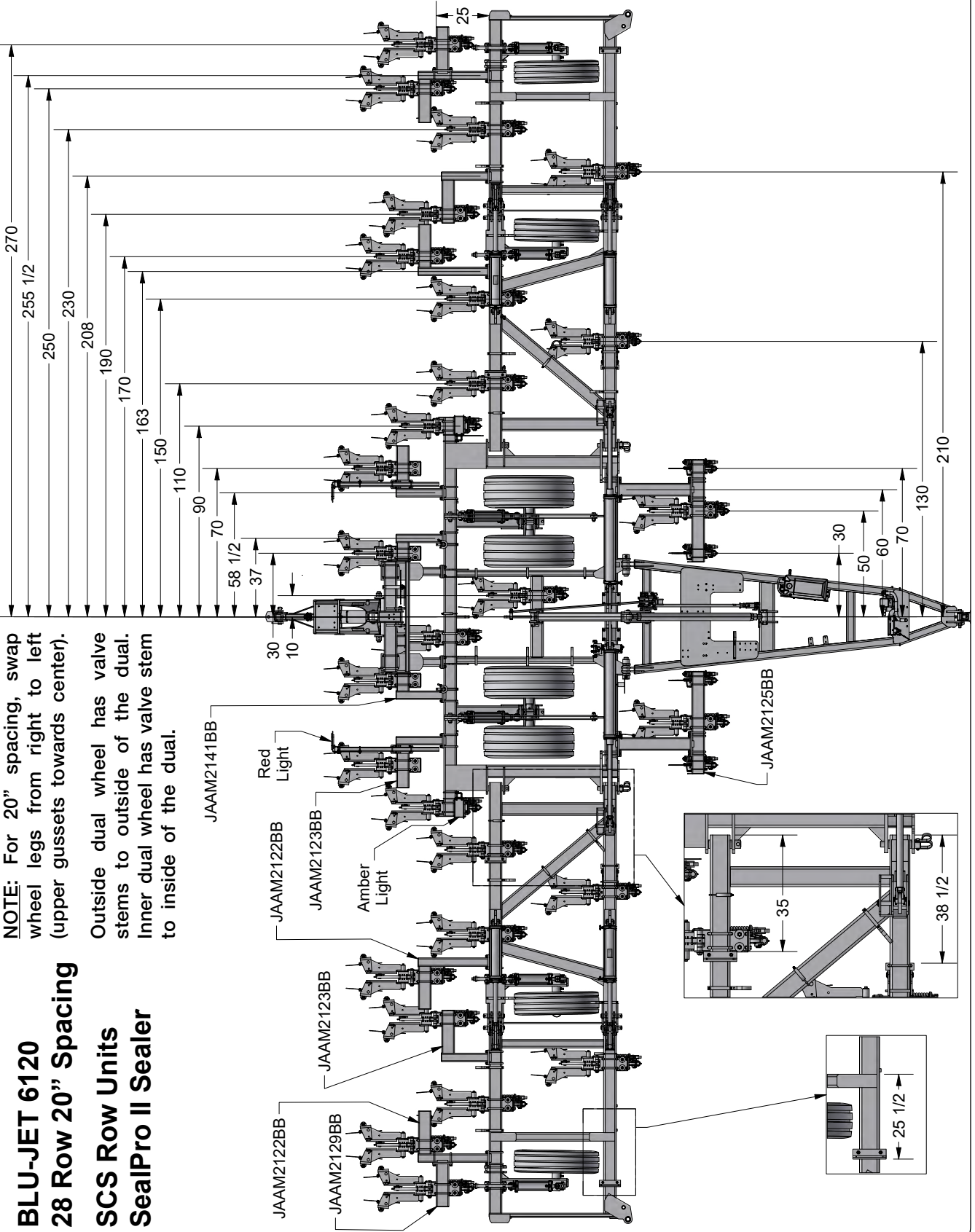

BLU-JET 6120
28 Row 20" Spacing
SCS Row Units
SealPro II Sealer

Overhead Layout - 6120 - 28 Row 20" Spacing

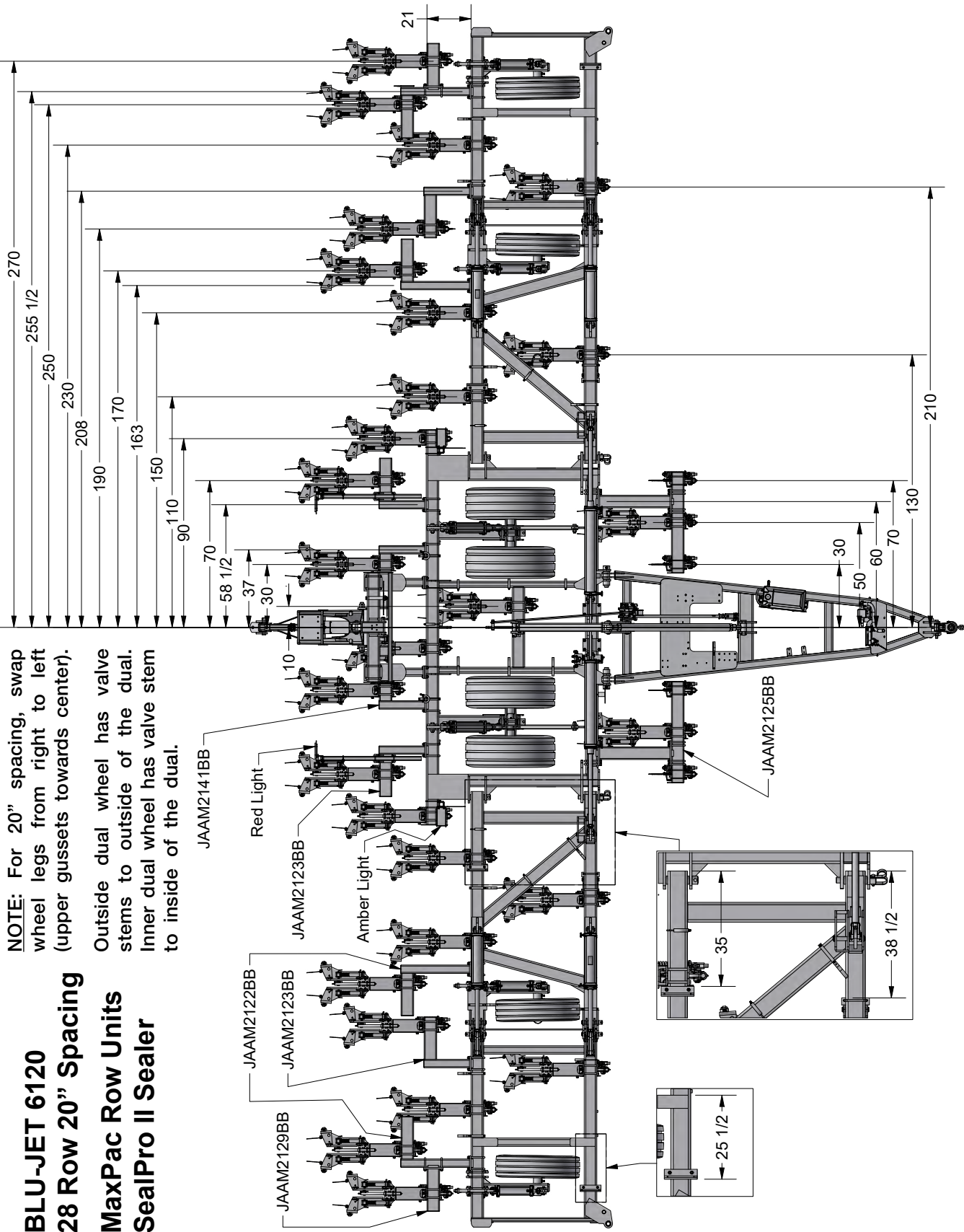

**BLU-JET 6120
28 Row 20" Spacing
MaxPac Row Units
SealPro II Sealer**

Overhead Layout - 6120 - 36 Row 20" Spacing

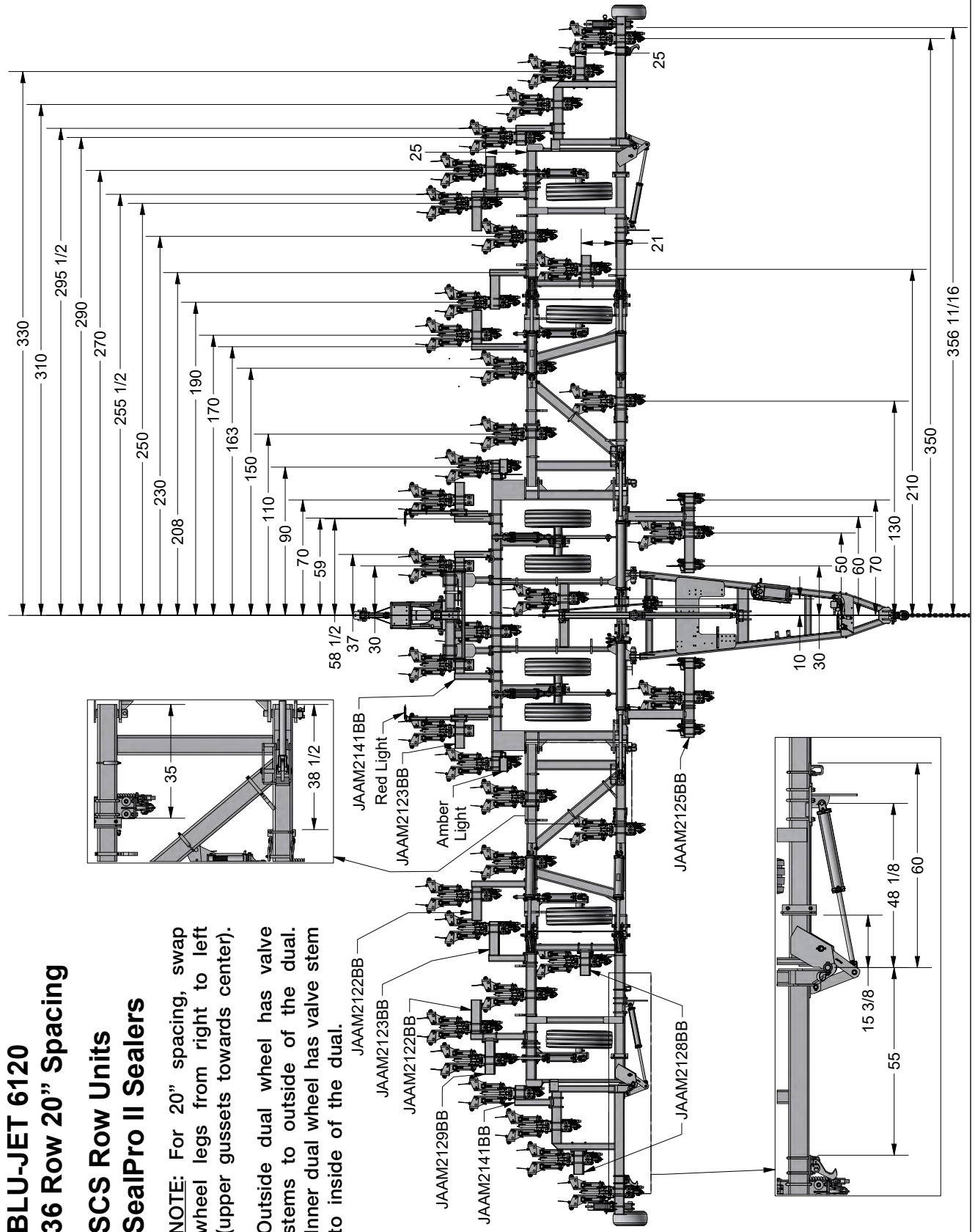

**BLU-JET 6120
36 Row 20" Spacing**

**SCS Row Units
SealPro II Sealers**

NOTE: For 20" spacing, swap wheel legs from right to left (upper gussets towards center).

Outside dual wheel has valve stems to outside of the dual.
Inner dual wheel has valve stem to inside of the dual.

Overhead Layout - 6120 - 36 Row 20" Spacing

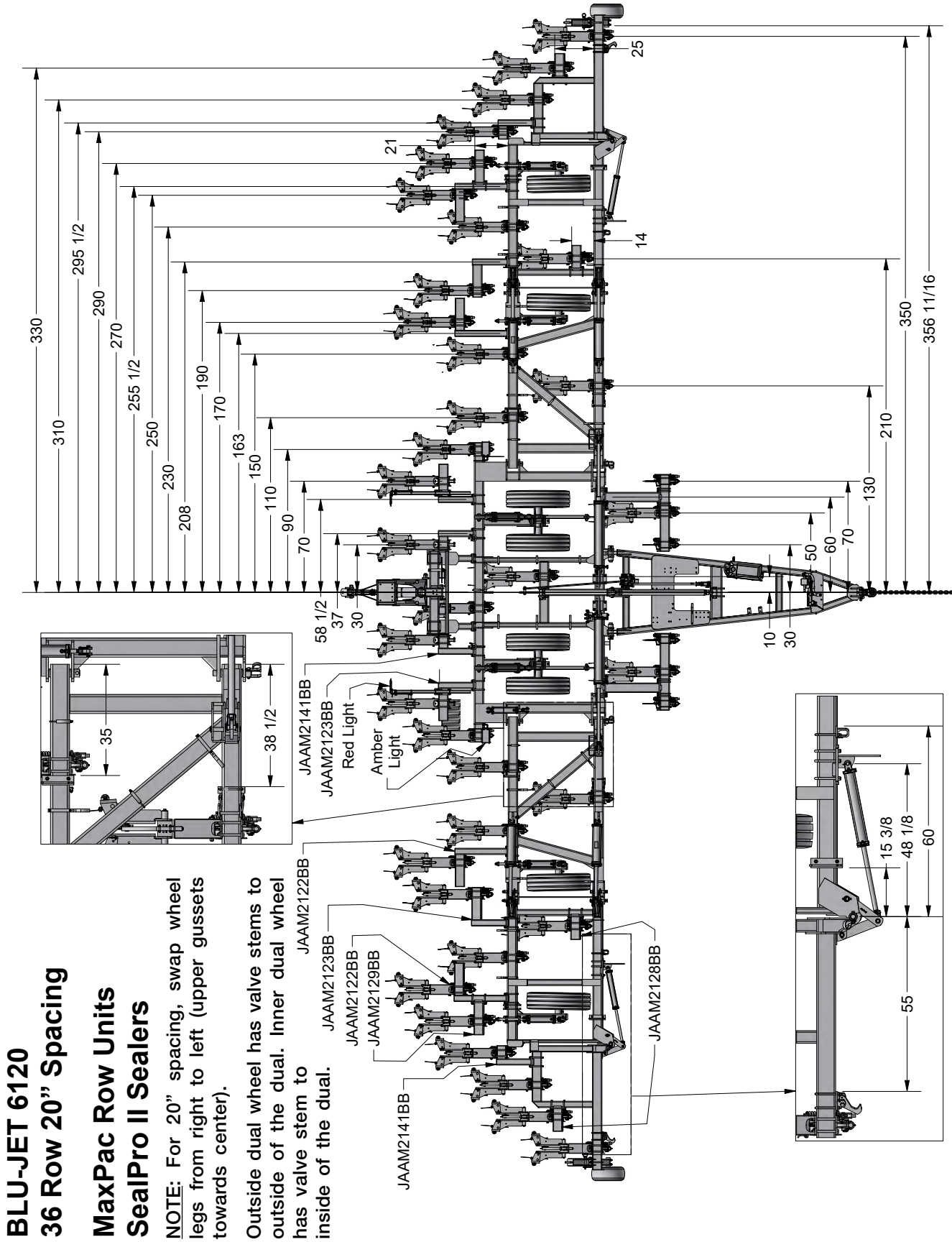

AgLeader RCM Guide

Direct Command Set Up

Whenever the tractor is turned off or the ECU for the anhydrous applicator loses power, the following steps will have to be performed in order for the RCM to function properly right away.

NOTE: Before programming the RCM, ensure the RCM monitor is connected to the battery.

Initial Settings

1. On the initial start-up screen, begin by entering the boom icon on the left.
2. Select the “wrench icon” on the right.
3. Select “System Settings”.
 - a. The Direct Command Unit will have 2 available System Configurations – A & B, Noted on the “Sprayer Icon” on the left. You can switch between the two for different implement applications.

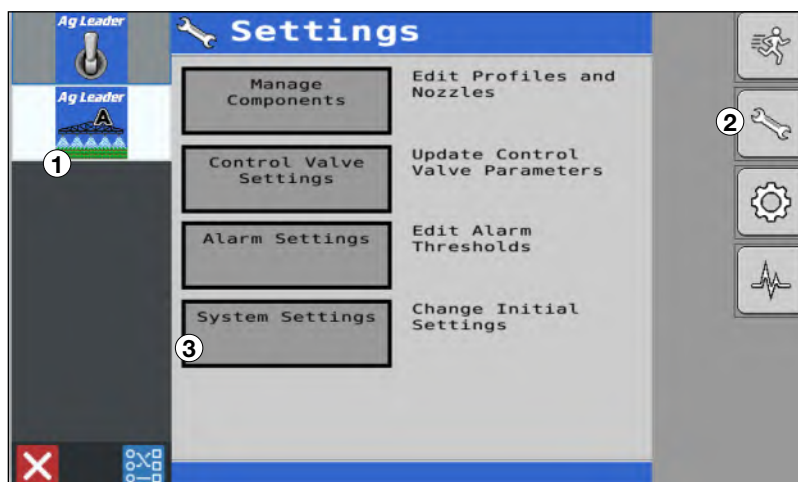

4. If not prompted to create a new Configuration, hit “Reset” to overwrite the current configuration

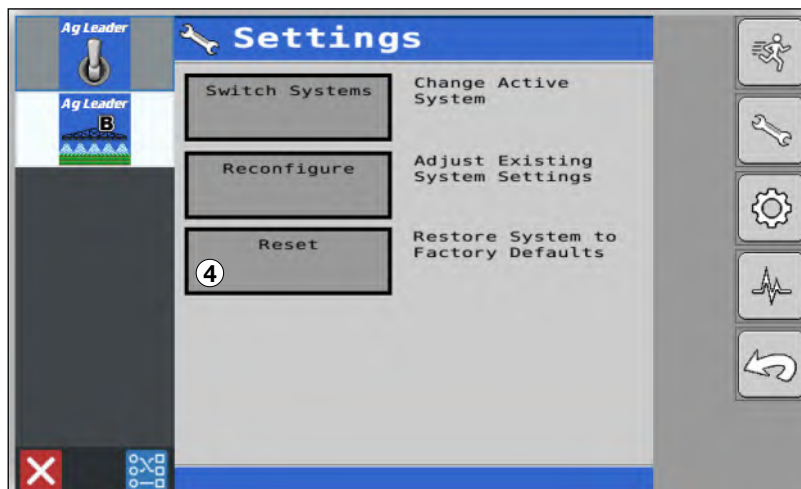

AgLeader RCM Guide (continued)

5. Configure your equipment as shown:

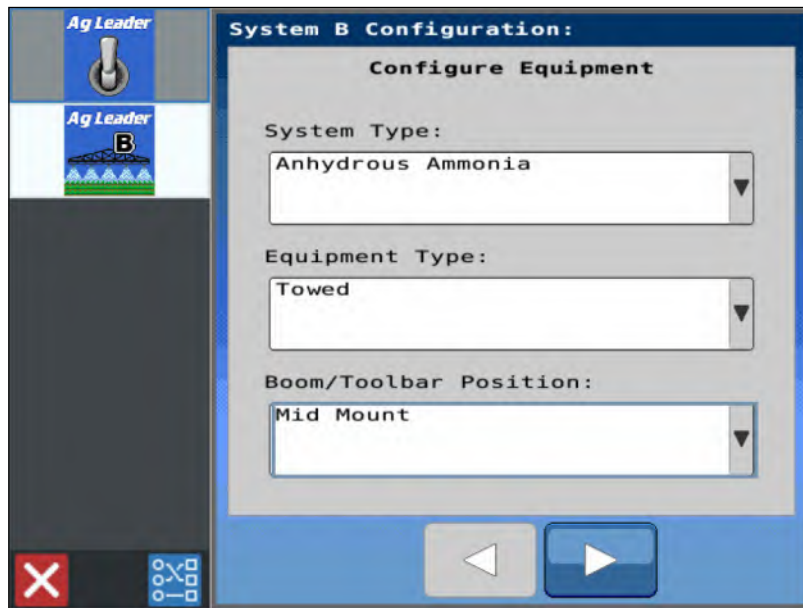

6. Controllers are automatically sensed – Change the number of sections if necessary.

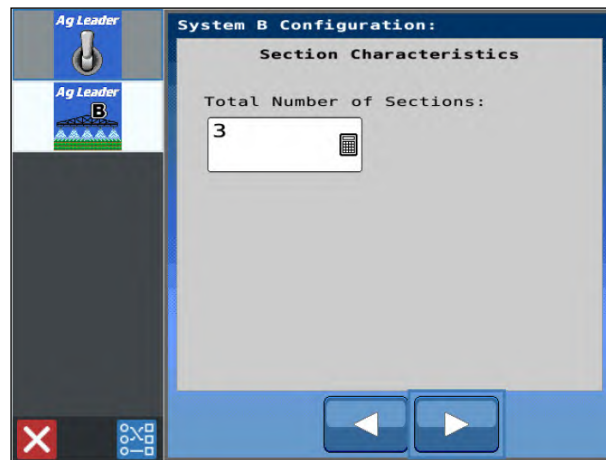
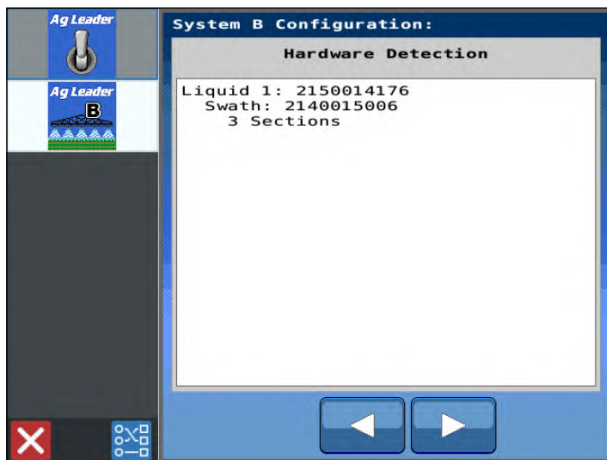

AgLeader RCM Guide (continued)

7. Signal type for Section valves.

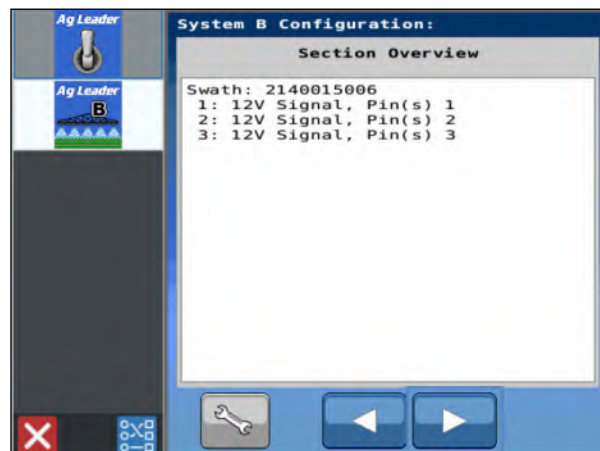
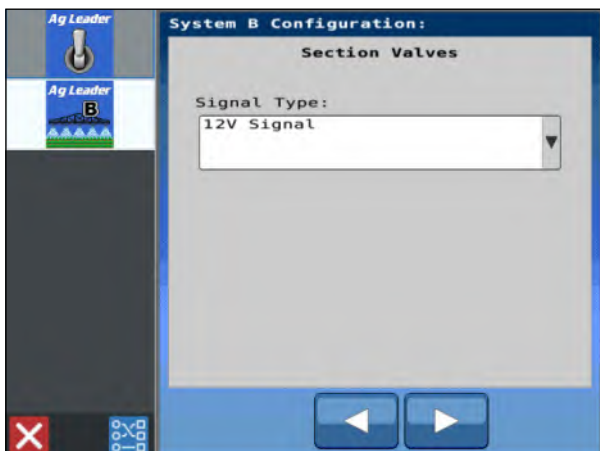

8. Name your profile.

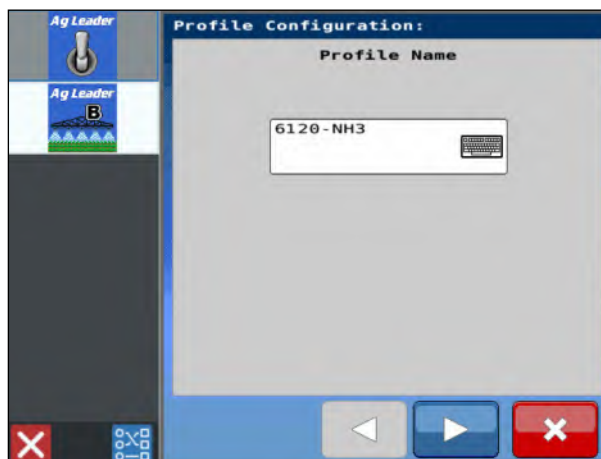

9. Enter row spacing for your machine.

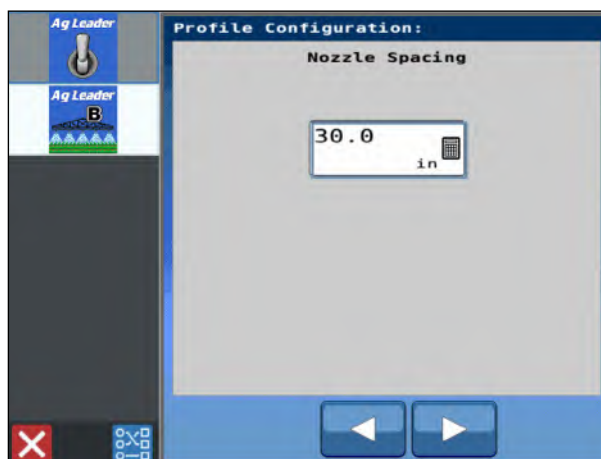

AgLeader RCM Guide (continued)

10. Section Setup – Enter the amount of rows for each section, using the up & down arrows and the entry field on the bottom left.

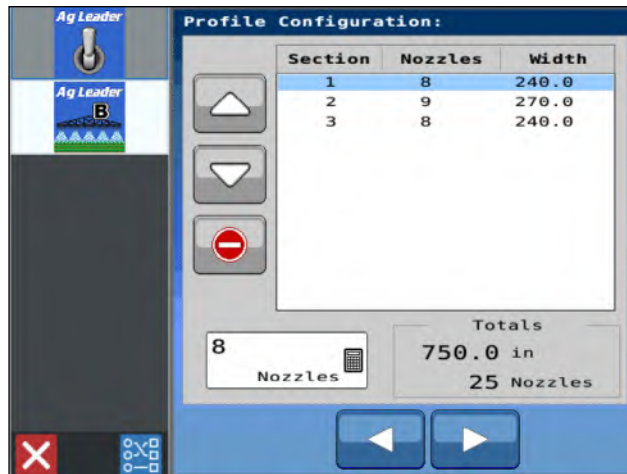

11. Enable Direct Injection Communication – Check **ONLY IF** you are using direct injection.

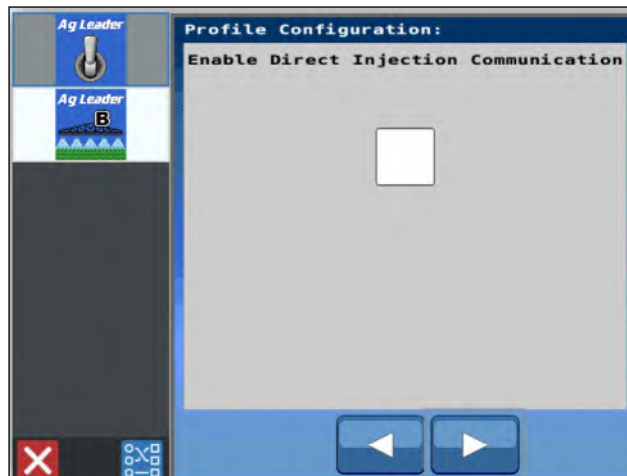

12. Channel Configuration – This is the Product Monitor
a. Name & Enter capacity

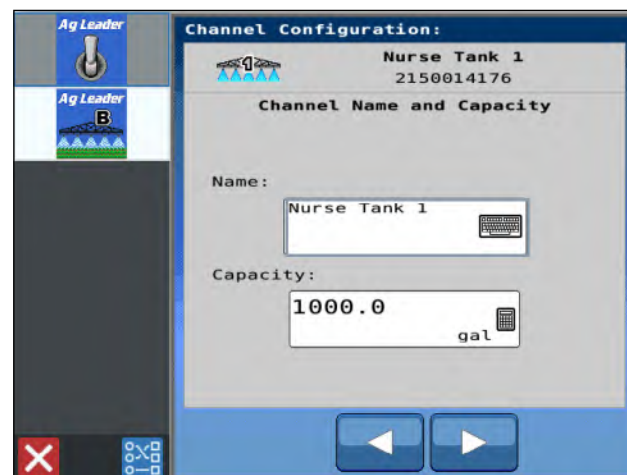

AgLeader RCM Guide (continued)

13. Rate Control Settings – Reference chart at the end of this document
 - a. Fast Valve – Single Control Valve
 - b. Standard Valve – Dual Control Valve
 - c. Typical Setup uses the parameters below:

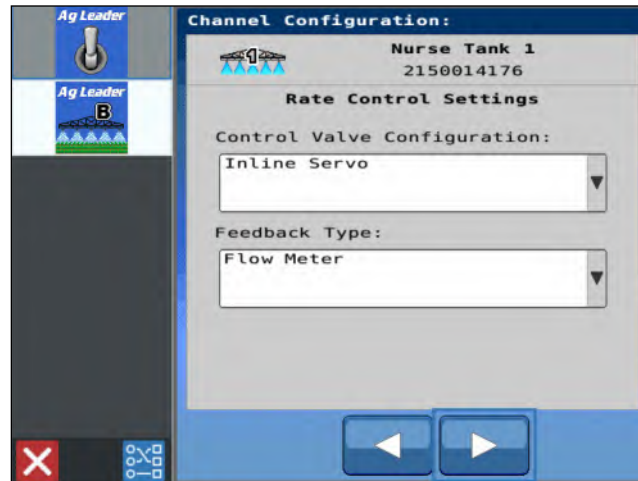

14. Rate off Settings
 - a. Aux Valve 1 – Boost Pump (If Present)
 - i. Always Closed
 - b. Aux Valve 2 – On/Off Valve in dual valve application
 - i. Always Closed
 - c. Control Valve – Rate metering Valve (Used in all applications)
 - i. Single Fast Valve – Closed
 - ii. Dual Valve – Hold



AgLeader RCM Guide (continued)

15. Task Controller Offsets – Measure to indicated points on your machine.

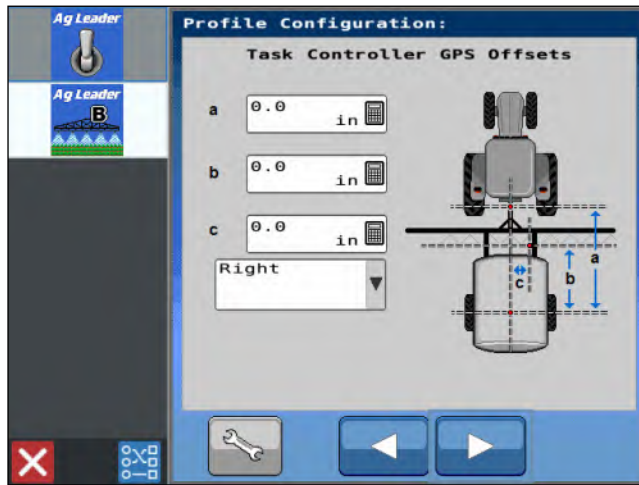

AgLeader RCM Guide (continued)

Control Hardware Set Up

16. Select the Wrench Icon again, and navigate to “Control Valve Settings”.

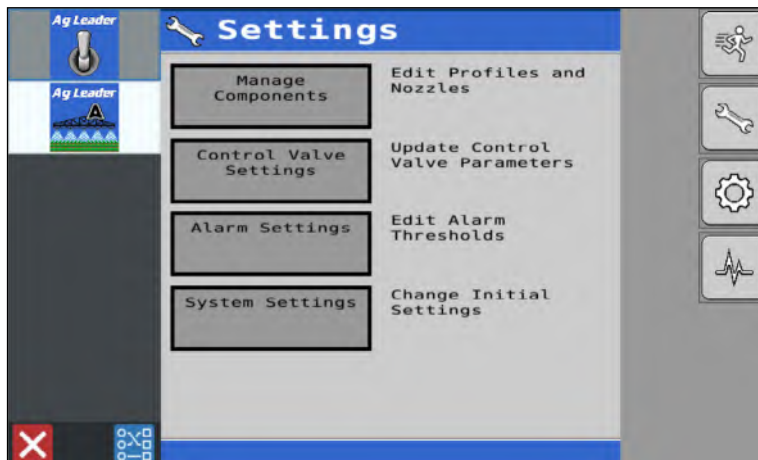

17. Reference Chart at the end of this document for suggested values
 a. Note that these values are based on your equipment’s hardware & Setup.
 i. Numbers Below are for a 30 gpm, Single Valve System

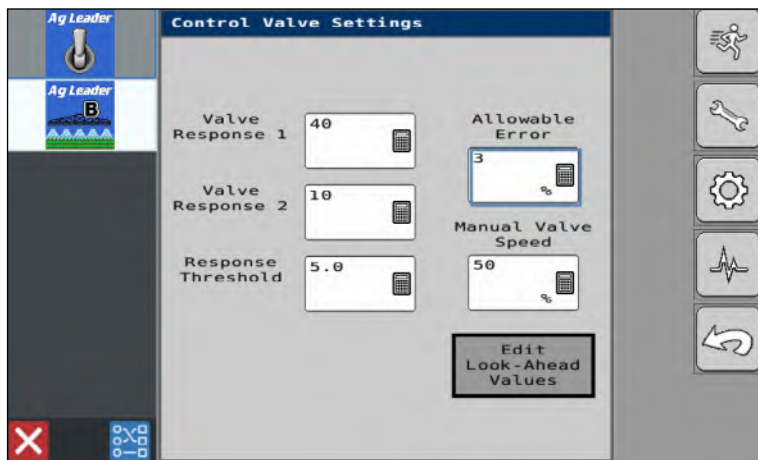

18. Select the Wrench Icon again, and navigate to the Alarm Settings – Set as desired

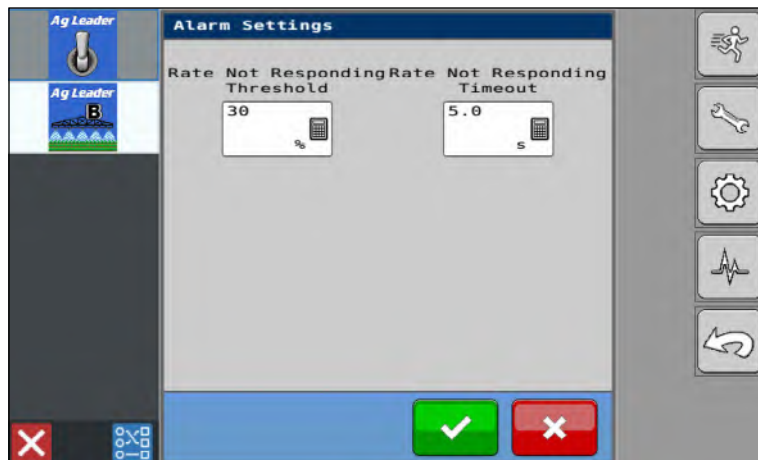

AgLeader RCM Guide (continued)

19. Select the Gear Icon on the right to calibrate sensors
 - a. Pressure Sensor
 - i. Select Wrench Icon on bottom left



- ii. Set the Main to "Voltage", Aux to "Not Used"

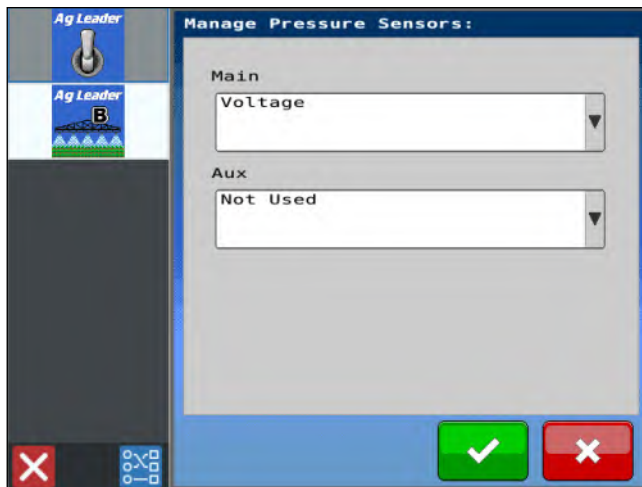

- iii. Single Set Point

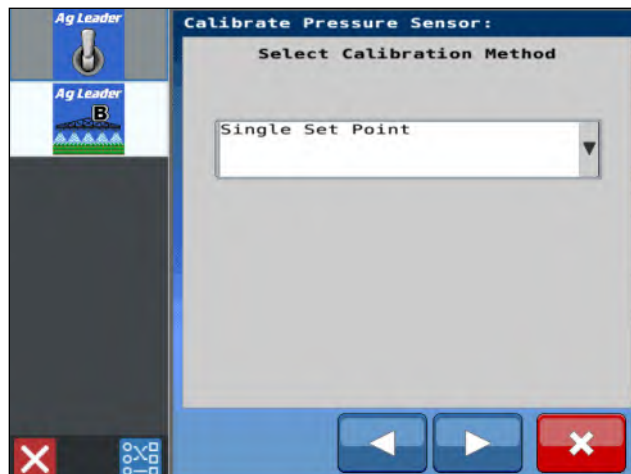

AgLeader RCM Guide (continued)

iv. Derive Sensor Calibration

Ag Leader

Calibrate Pressure Sensor:

Enter Calibration Number

16.0 mV/psi

Derive Sensor Calibration

v. Enter Values Below:

- I. These are the sensor's operating parameters, available on the tag attach to your sensor.

Ag Leader

Calibrate Pressure Sensor:

Enter Sensor Characteristics

Min Pressure: 0 psi

Max Pressure: 250 psi

Min V/A: 1.0 v

Max V/A: 5.0 v

Calculate

AgLeader RCM Guide (continued)

- vi. Record Setpoint of the Depressurized system
 - I. (This effectively Zeroes the sensor)

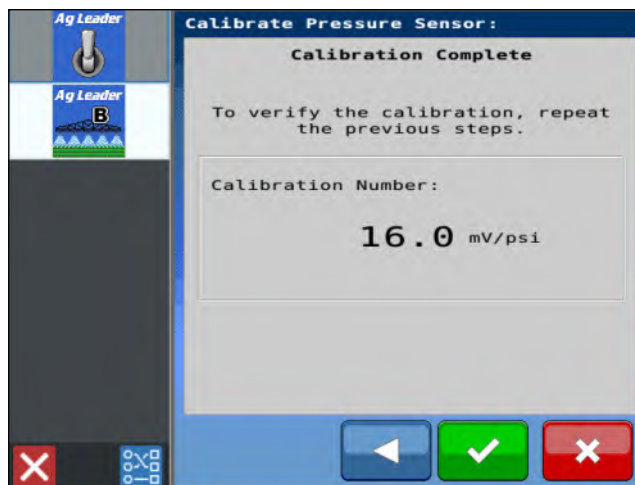
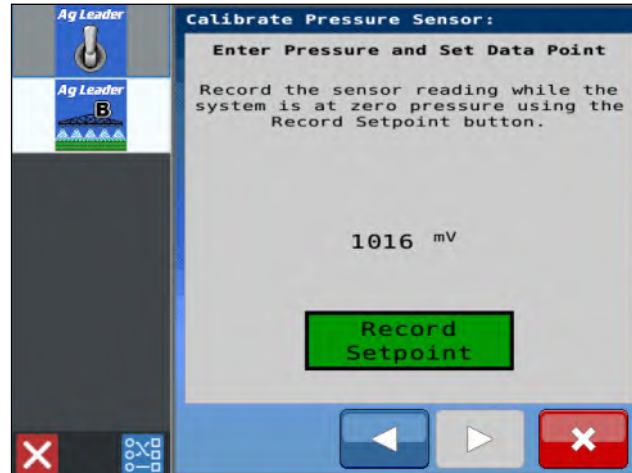

AgLeader RCM Guide (continued)

- b. Flow Sensor – Flow meters are unique. Reference the Part number tag for proper calibration numbers. Be sure to note the unit of measurement – Raven Sensors are noted as Pulses/10 gal. You must divide the Cal number by 10 to get Pulses/Gal

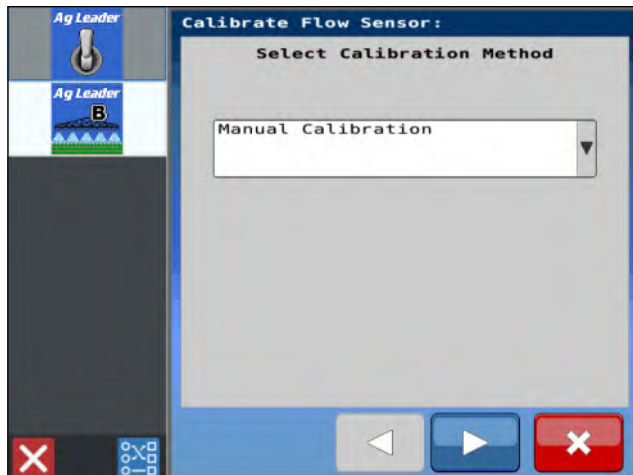

- c. Temperature Sensor (Vapor Sensor 9503384)
i. Select Temperature Sensor



AgLeader RCM Guide (continued)

ii. Derive Sensor Calibration

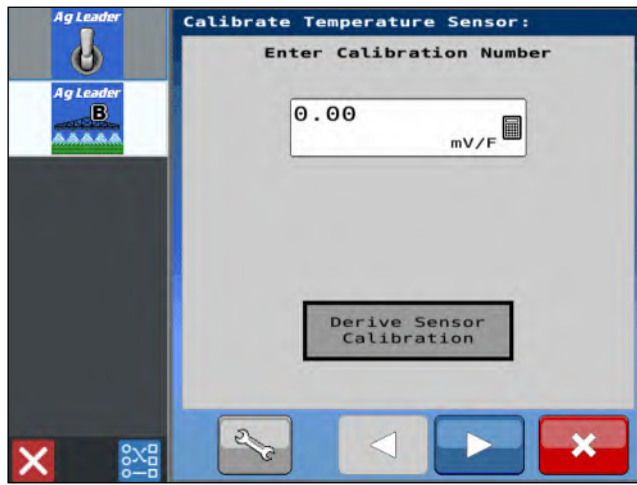

- iii. Enter Numbers based on Sensor Part Number Tag
 - I. NOTE THE UNITS USED (Fahrenheit vs. Celsius)
- iv. Select "Calculate"

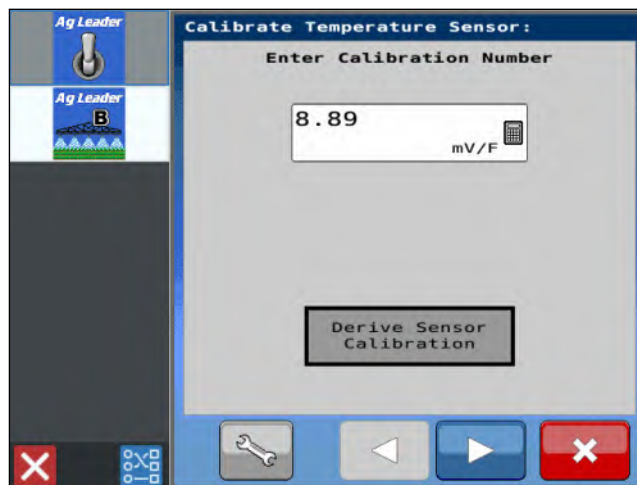
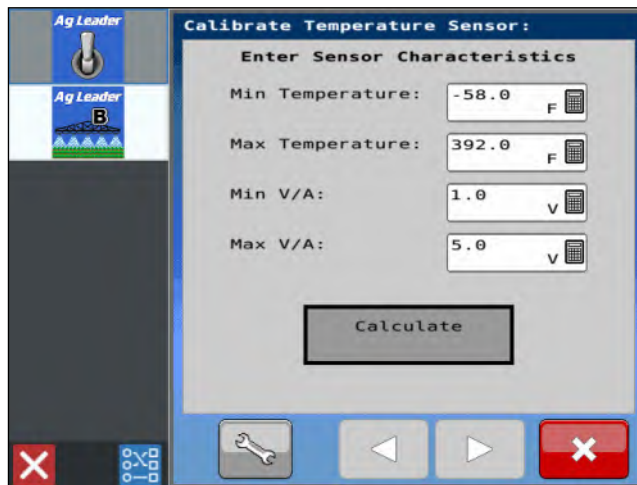

AgLeader RCM Guide (continued)

- v. Enter Current Temperature
 - I. This can be found when the machine is discharged, and preferably sitting in a shaded building. The Ambient temperature in this scenario should be adequate.
 - II. Alternatively, accurate measurements can be obtained by inserting the sensor into saltwater at exactly 32 deg. F

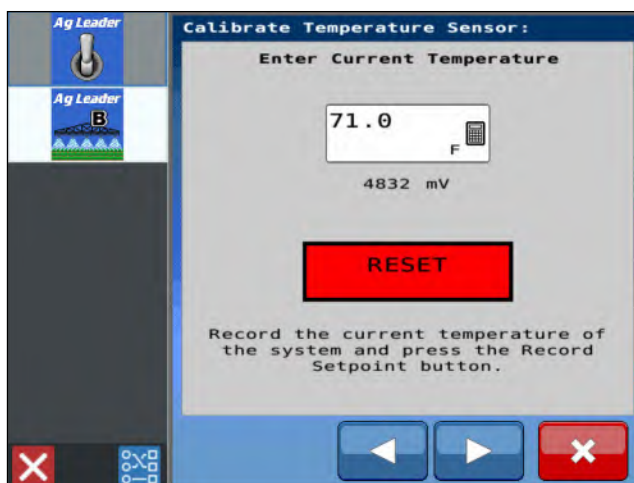

AgLeader RCM Guide (continued)

Operation Parameter Setup

20. Navigate to the Run Page

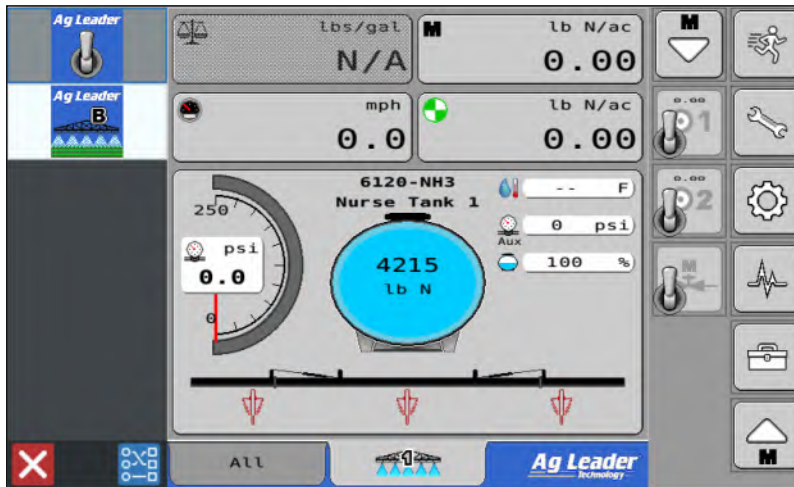

21. Select the Top Right Display for rate control parameters – Set desired rates & units

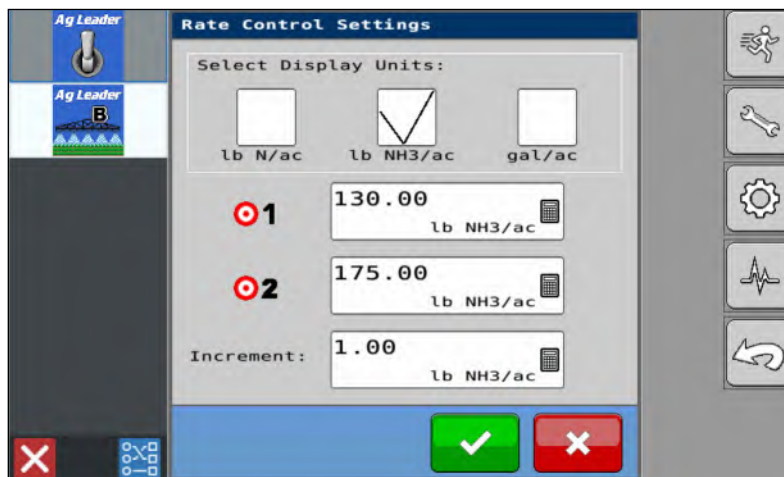

AgLeader RCM Guide (continued)

22. Select the Bottom Right Display to enable rate smoothing

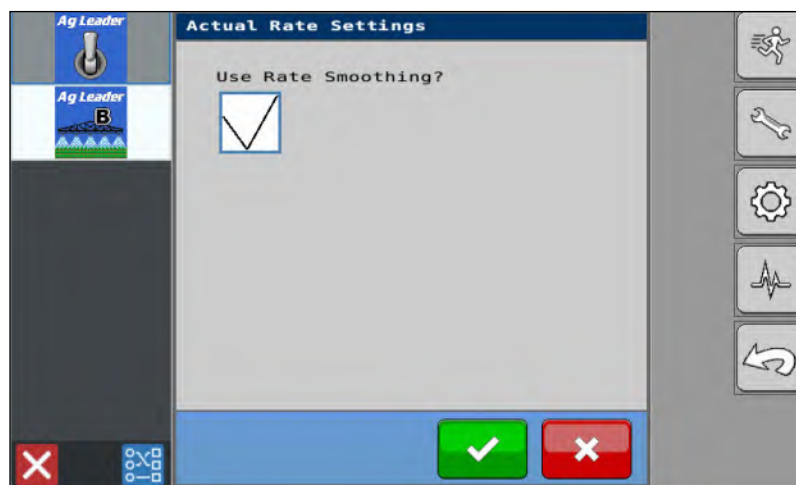

23. Select the Product Tank Icon – Modify parameters as needed

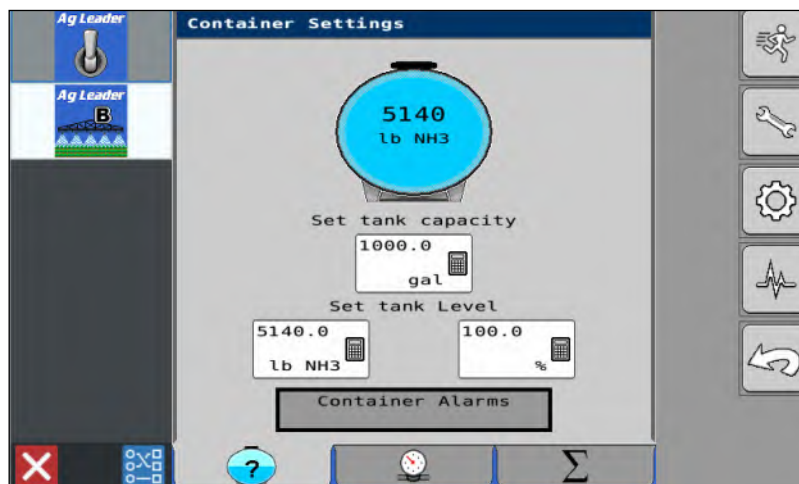

AgLeader RCM Guide (continued)

AgLeader Resources

Setting Name	Description
Control Valve Configuration	<p>Inline Servo: Rate control is achieved through actuating a control valve in the solution hose that goes to the booms. When the valve opens flow increases and when the valve closes, flow decreases.</p> <p>Bypass Servo: Rate control is achieved through actuating a control valve in the return line to the solution tank. When the valve opens, the flow decreases and when the valve closes the flow increases.</p>
Valve Response 1	Determines the speed of the servo valve when product control error exceeds the Response Threshold setting. Decreasing the value will cause the servo valve to run slower
Valve Response 2	Determines the speed of the servo valve when product control error is less than the Response Threshold setting. Decreasing the value will cause the servo valve to run slower.
Allowable Error	Determines the percent of error that is allowed prior to the product control system making any flow rate corrections. 2 % – 3 % is the normal dead band setting range. Too low of a setting will cause the control system to continually hunt for the target application rate. Too high of a setting will cause excessive application error.
Response Threshold	<p>Determines where the control system switches between using Valve response 1 and Valve response 2 speed settings. Decreasing this value will have the overall effect of speeding up servo valve response. Increasing this value will have the overall effect of slowing down servo valve response.</p> <p><i>NOTE: Leaving all other valve control settings at the default value and making a small adjustment to this setting is usually all that is required to fine-tune the control system.</i></p>
Flow Meter Cal	This is the number pulses per 10 gallons of product flow thru the Raven flow meter. The Ag Leader Display requires pulses per gallon for calibration. To calculate the appropriate values divide the Raven calibration number by 10 before entering into the Ag Leader Display.

AgLeader RCM Guide (continued)

SERVO VALVE CONTROL SETTINGS				
Flow Control Valve	Control Valve Configuration	Valve Response 1	Valve Response 2	Response Threshold
Raven Accu-Flow 20 gpm, Single Valve System (FAST VALVE)	Inline Servo	40%	10%	5
Raven Accu-Flow 20 gpm, Two Valve System (STANDARD VALVE)	Inline Servo	100%	24%	5
Raven Accu-Flow 30 gpm, Single Valve System (FAST VALVE)	Inline Servo	40%	10%	5
Raven Accu-Flow 30 gpm, Two Valve System (STANDARD VALVE)	Inline Servo	100%	24%	5
Raven Flow Control Valve (3/4" STANDARD VALVE)	Inline Servo or Bypass Servo	100%	24%	1
Raven Flow Control Valve (3/4" FAST VALVE)	Inline Servo or Bypass Servo	40%	10%	5
Raven Flow Control Valve (1" STANDARD VALVE)	Inline Servo or Bypass Servo	100%	24%	2
Raven Flow Control Valve (1" FAST VALVE)	Inline Servo or Bypass Servo	40%	10%	5
Flow Control Valve (1-1/2" STANDARD VALVE)	Inline Servo or Bypass Servo	100%	24%	3
Raven Flow Control Valve (2" STANDARD VALVE)	Inline Servo or Bypass Servo	100%	24%	8
Raven Flow Control Valve (2" FAST VALVE)	Inline Servo or Bypass Servo	40%	10%	15
Raven Flow Control Valve (3" STANDARD VALVE)	Inline Servo or Bypass Servo	100%	24%	15

Notes

SECTION III

Operation

Preparing Tractor	3-2
Preparing Applicator.....	3-2
Hardware.....	3-2
Pivot Pins	3-2
Hitch	3-2
Hydraulic System.....	3-2
Tires/Wheels.....	3-3
Lubrication	3-3
Hitching to the Tractor.....	3-4
Drawbar Hitching.....	3-4
Transport Chain	3-5
Hydraulic Connections.....	3-6
Electrical Connection	3-6
Jack Usage.....	3-7
Parked Position.....	3-7
Transport Position	3-7
Transporting	3-8
Drawbar Connection	3-8
Toolbar Operation.....	3-9
Leveling Machine.....	3-9
Leveling Adjustable Gauge Wheels.....	3-10
Swing Adjust Gauge Wheels	3-11
Depth Adjustment	3-12
Locking Depth Adjustment Linkage.....	3-12
Hydraulic System Charging.....	3-13
Folding Toolbar.....	3-14
Secondary Wing Latch.....	3-15
Nurse Tank Hitch.....	3-15
Anhydrous Ammonia Operating Instructions	3-16
Checking System	3-17
Connecting Nurse Tank	3-17
Orifice Block Setting	3-18
Disconnecting Nurse Tank	3-19
Clean Water Tank	3-20
DiscCover Sealer (Options).....	3-20
Torsion Arm Basket (Options).....	3-20
SuperShooter (Options)	3-21
MaxPac AR700 (Options)	3-21
Residue Manager (Options).....	3-21
Operational Guide For Various Residue Situations.....	3-22

Preparing Tractor

Before operating applicator, read the tractor operator's manual and gain an understanding of its safe methods of operation.

Check the tractor brakes and transport lights. Make sure they are in proper working order.

Check the tractor hydraulic oil reservoir and add oil if needed.

Verify that the tractor is adequately ballasted for drawbar operation at the anticipated draft and vertical tongue load. Vertical tongue load of a loaded applicator is approximately 8,500 lbs. unfolded (4800 lbs. with toolbars folded to transport position). Ensure that the tractor's drawbar has sufficient strength to support this load.

If possible, adjust the tractor drawbar vertically so the top side of the drawbar is at least 18 inches from the ground. Alternately, the applicator hitch may be adjusted vertically by choosing other mounting holes provided.

Raise and secure all tractor 3-point hitch linkage to prevent interference with the implement tongue and hydraulic hoses during turning.

Preparing Applicator

Perform the service checks as outlined. Repair or replace any damaged or worn parts before operating.

Hardware

Check for loose bolts and nuts, and tighten as needed. Check again after the first half-day of operation.

Pivot Pins

Check that all pins are in place and in good condition. Replace any worn, damaged or missing pins.

Hitch

Check hitch and hitch retention hardware for damage and wear.

Hydraulic System

Check all hoses and cylinders for signs of leakage. Hoses should not be kinked, twisted or rubbing against sharp edges. Re-route or repair hoses as necessary. Refer to SAFETY section for additional information on safe repair and inspection of hydraulic components.

Preparing Applicator (continued)

Tires/Wheels

Check tire pressures and maintain at recommended values listed in the MAINTENANCE section.

CAUTION

- **IMPROPERLY TORQUED WHEEL NUTS/BOLTS CAN CAUSE A LOSS OF IMPLEMENT CONTROL AND MACHINE DAMAGE. WHEEL NUTS/BOLTS MUST BE CHECKED REGULARLY. SEE TORQUE PAGE IN THE “MAINTENANCE” SECTION FOR PROPER WHEEL NUT/BOLT SPECIFICATIONS. WARRANTY DOES NOT COVER FAILURES CAUSED BY IMPROPERLY TORQUED WHEEL NUTS/BOLTS.**

IMPORTANT

- *Installing wheels without the proper inset could result in hub or spindle failure. This will cause substantial damage to the applicator.*

For questions regarding new tire warranty, please contact your local original equipment tire dealer. Used tires carry no warranty. Tire manufacturers' phone numbers and web sites are listed in the “MAINTENANCE” section for your convenience.

Lubrication

Lubricate the applicator as outlined in the MAINTENANCE section.

Hitching to the Tractor

Drawbar Hitching

⚠ WARNING

- **DO NOT STAND BETWEEN THE IMPLEMENT AND TRACTOR WHEN HITCHING. ALWAYS ENGAGE PARKING BRAKE AND STOP ENGINE BEFORE INSERTING HITCH PIN.**

Connect the hitch to the tractor drawbar. Do not attempt to hitch to any other location on the tractor. (FIG. 3-1)

NOTE: Only use the centered position on the tractor drawbar.

The implement is equipped with a single-tang ball swivel hitch (JAP3232) and requires a 2" diameter drawbar pin. Clevis hitch (JAM2144) requires a 1 1/4" diameter drawbar pin.

FIG. 3-1

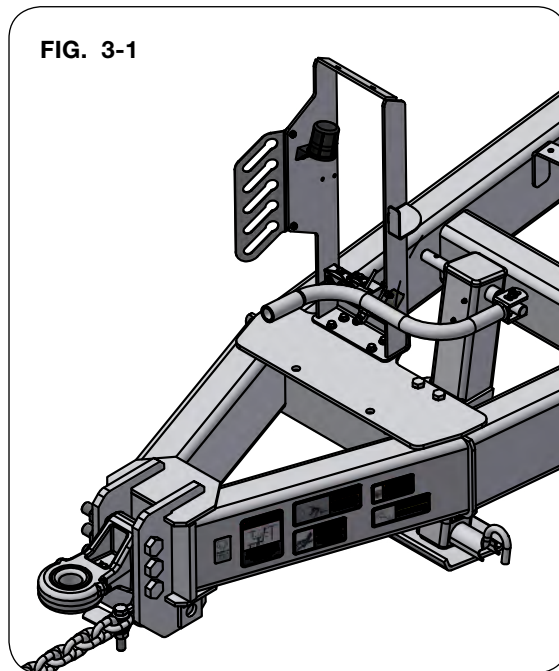

IMPORTANT

- *The use of a smaller-diameter hitch pin will result in additional clearance between the implement hitch and pin. This additional clearance may cause accelerated pin and hitch wear, along with more pronounced jolting from the implement during operation.*

Hitching to the Tractor (continued)**Transport Chain****⚠ CAUTION**

- REPLACE TRANSPORT CHAIN IF ANY LINK OR END FITTING IS BROKEN, STRETCHED, DAMAGED OR NOT FUNCTIONING. DO NOT WELD TRANSPORT CHAIN.

Always use a transport chain when connecting the implement directly to a tractor. Make sure the intermediate chain support is in use. DO NOT use the intermediate chain support as the chain attaching point. FIG. 3-2 shows how the transport chain must be installed between the tractor and implement.

Transport chain should have a minimum rating equal to the gross weight of the implement and all attachments. Use only ASABE approved chain. Allow no more slack in the chain than necessary to permit turning.

Transport chain connection shown for illustration purposes only. Refer to tractor manufacturer for proper attachment.

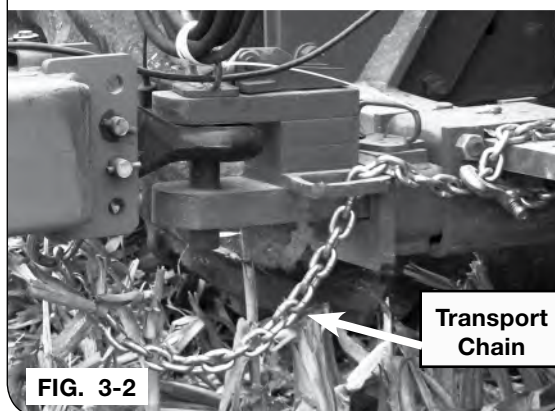

Hitching to the Tractor (continued)**Hydraulic Connections**

After cleaning hydraulic hose couplers, connect to tractor hydraulic circuits.

CAUTION

- **DO NOT UNFOLD OR FOLD TOOLBAR WITHOUT HITCHING TO THE TRACTOR.**

1. Connect the toolbar hydraulic hoses to the tractor remote couplers. The 1/2" hoses supply oil to the toolbar lift cylinders. The 3/8" hoses supply oil to the wing fold cylinders.

NOTE: Always connect the hoses so the toolbar raises when the tractor remote control lever is moved rearward and lowers when the lever is moved forward.

Refer to the MAINTENANCE SECTION for flow diverter valve setup information.

Before disconnecting hoses from the tractor, relieve pressure from the lines. See tractor's operators manual for proper procedure to relieve pressure.

WARNING

- **AFTER INITIAL SET-UP OR REPLACEMENT OF ANY HYDRAULIC COMPONENT ON THE APPLICATOR, AIR MUST BE REMOVED FROM THE WING-FOLD HYDRAULIC SYSTEM PRIOR TO ITS FIRST USE. FAILURE TO DO SO MAY RESULT IN DAMAGE TO TOOLBAR COMPONENTS DUE TO RAPID MOVEMENT.**

Electrical Connection

The main harness has a 7-pin (round) plug conforming to SAE standards that connects to tractor. If your tractor does not have the mating socket connector, contact your tractor dealer. (FIG. 3-3)

The wiring schematic for this applicator, as shown in the maintenance section, complies with current ASABE standards. Always verify correct electrical function before using this applicator.

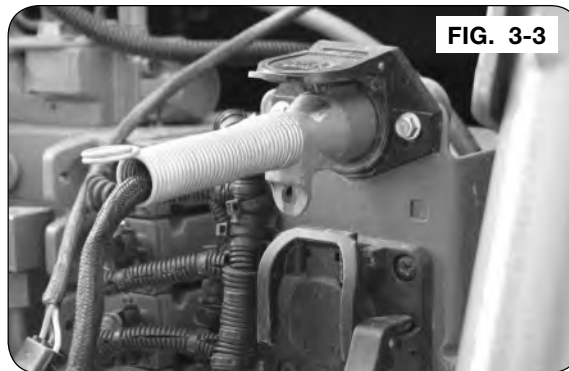

Jack Usage

Parked Position

Lower drop leg to contact the ground. Crank jack leg downward to completely remove the hitch weight from tractor drawbar. (FIG. 3-4)

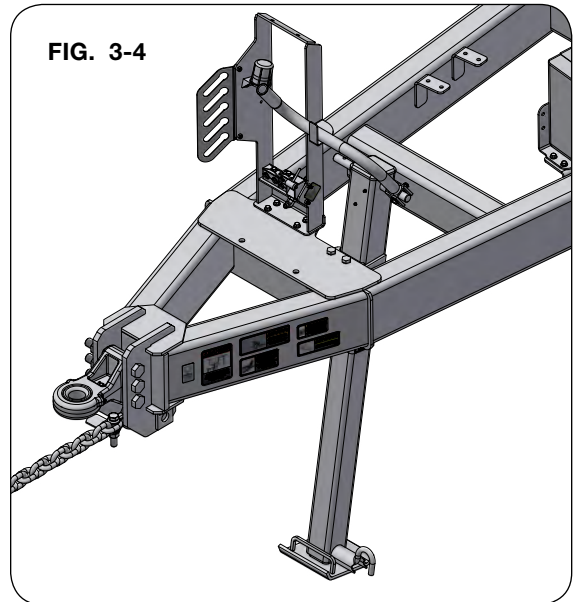

Transport Position

After tractor connection is established, raise jack leg to highest position to maximize ground clearance. (FIG. 3-5)

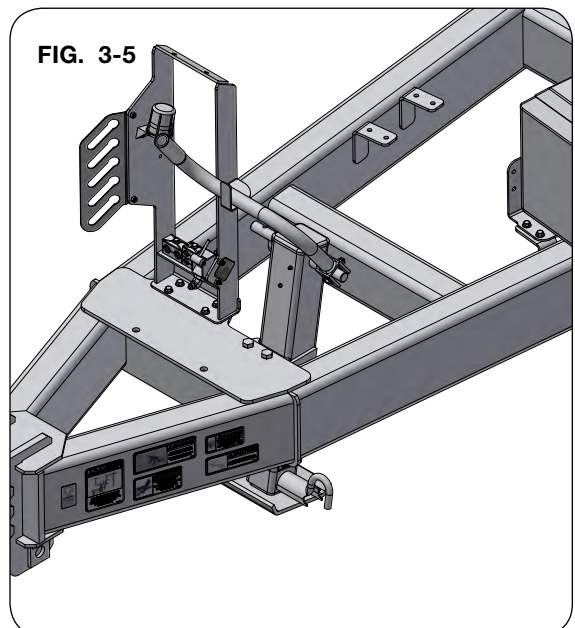

Transporting

Drawbar Connection



CAUTION

- **THIS IMPLEMENT IS NOT EQUIPPED WITH BRAKES. ENSURE THAT THE TOWING VEHICLE HAS ADEQUATE WEIGHT AND BRAKING CAPACITY TO TOW THIS IMPLEMENT.**
- **IMMEDIATELY PRIOR TO ROAD TRANSPORT, RUN THE FULL FOLD SEQUENCE FOR PROPER SYSTEM PRESSURES AND TO AVOID INADVERTENT MOVEMENT.**

See towing vehicle manual for towing and braking capacity. Regulate speed to road conditions. Maximum speed of applicator with wheels should never exceed 20 m.p.h.

Secure drawbar pin with a locking device and lock tractor drawbar in centered position.

Secure transport chain to tractor before transporting. Use good judgment when transporting equipment on highways. Regulate speed to road conditions and maintain complete control.

Lock fold hydraulics to prevent inadvertent operation during transport.

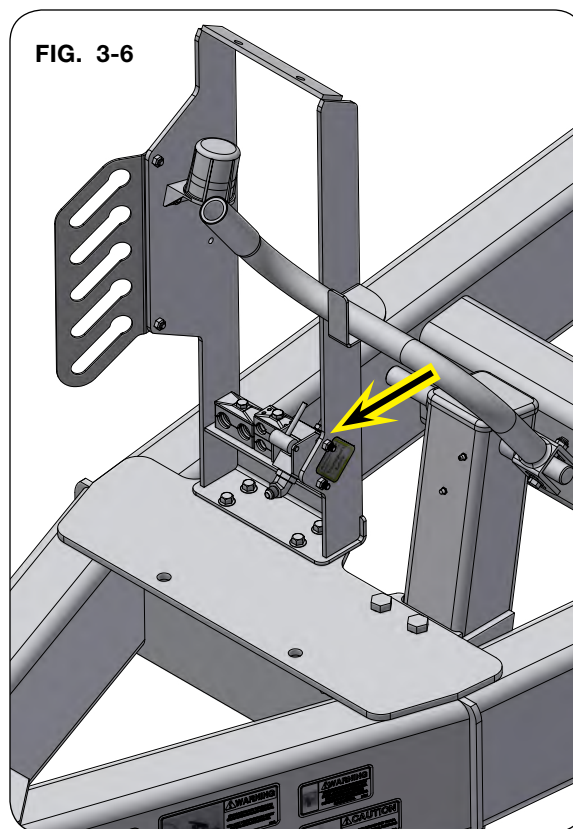

It is probable that this implement is taller, wider, and longer than the towing tractor. Become aware of and avoid all obstacles and hazards in the travel path of the equipment, such as power lines, ditches, etc.

Slow down before making sharp turns to avoid tipping. Drive slowly over rough ground and side slopes.

Toolbar Operation

DANGER

- ELECTROCUTION WILL CAUSE SERIOUS INJURY OR DEATH. PERFORM FRAME UNFOLDING AND FOLDING OPERATIONS ONLY IN AREAS WITH ADEQUATE HEIGHT, WIDTH AND LENGTH CLEARANCE. IN PARTICULAR, BE MINDFUL OF LOCATION OF OVERHEAD POWER LINES.

WARNING

- KEEP ALL PERSONNEL A SAFE DISTANCE AWAY FROM THE IMPLEMENT WHEN UNFOLDING OR FOLDING THE TOOLBAR. PERSONAL INJURY CAN RESULT FROM IMPACT WITH FRAME.
- DO NOT EXCEED 10 MPH DURING OFF-HIGHWAY TRAVEL.

Leveling Machine

IMPORTANT

- *Never unfold the unit without attaching to tractor first. Refer to “Hitching to the Tractor” and “Jack Usage” in this section.*
1. Before leveling the machine the tire pressure should be checked. Inflate center section lugged tractor tires to 51 PSI maximum; truck tires 95 PSI maximum.

Before beginning operation of this machine the main frame must be level. Place toolbar on level surface. Use the turnbuckle wrench to loosen the lower turnbuckle jam nut. Adjust turnbuckle with wrench until the main frame is level front to back. After making the necessary adjustment, lock turnbuckle with jam nut.

2. Unlock transport lock before unfolding toolbar.

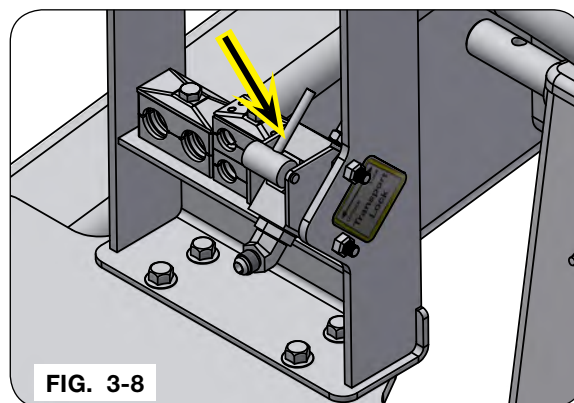
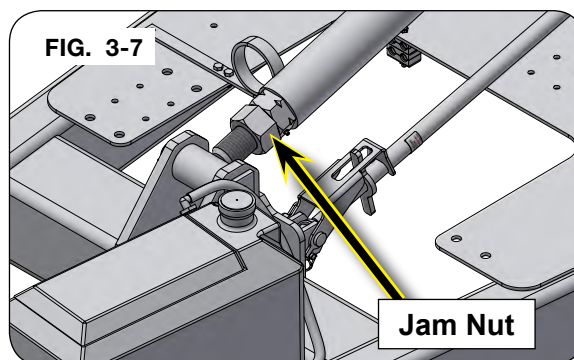

Toolbar Operation (continued)

Leveling Adjustable Gauge Wheels

NOTE: Adjust until toolbar is level across the entire bar

1. Check tire pressure before adjusting. Loosen the two 1" x 4" hex bolts at the top of the adjust linkage. Loosen 1" hex nut on inside of threaded rod. Turn 1" hex nut on outside clockwise to lower wing and counter clockwise to raise wing. Secure both nuts on threaded rod against cylinder lug adjust. Tighten 1" x 4" hex cap screws after wheel adjustment.

NOTE: Coulter will require final working depth adjustment in the field.

Tighten one inch hex nuts after wheel adjustment.

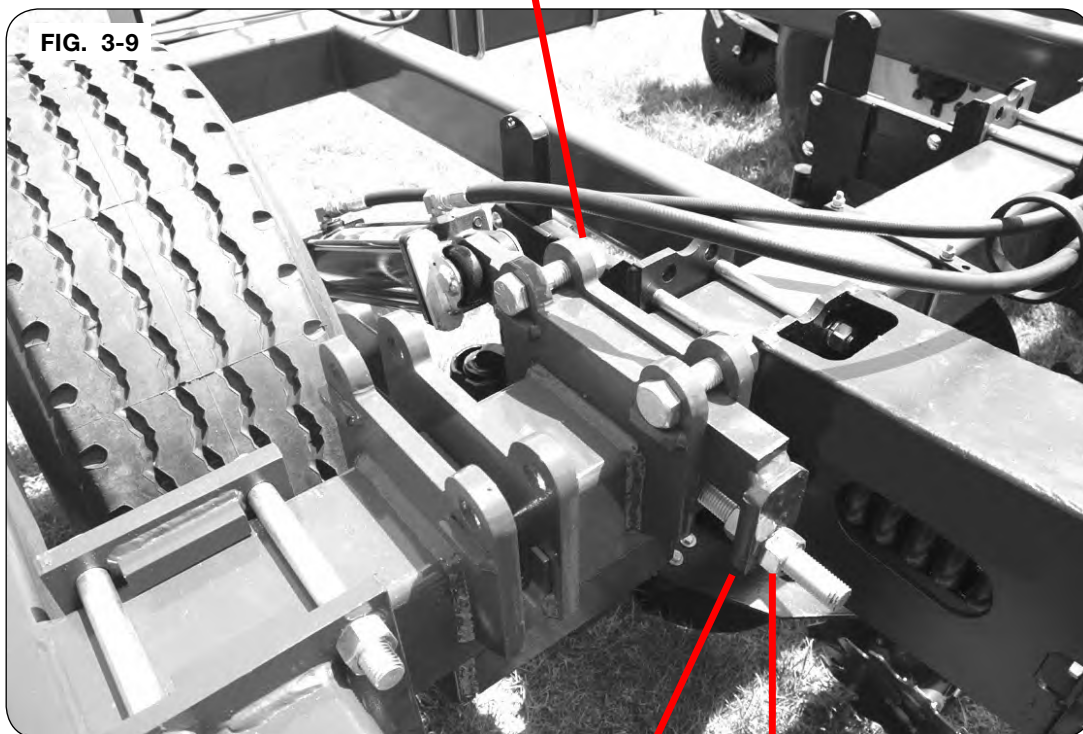

FIG. 3-9

Cylinder lug adjust

One inch hex nut

Toolbar Operation (continued)

Swing Adjust Gauge Wheels

1. Adjust pin adjust gauge wheel to level position with the hydraulic gauge wheel.



Toolbar Operation (continued)

Depth Adjustment

1. One complete revolution equals 1/2" of depth increase or decrease.

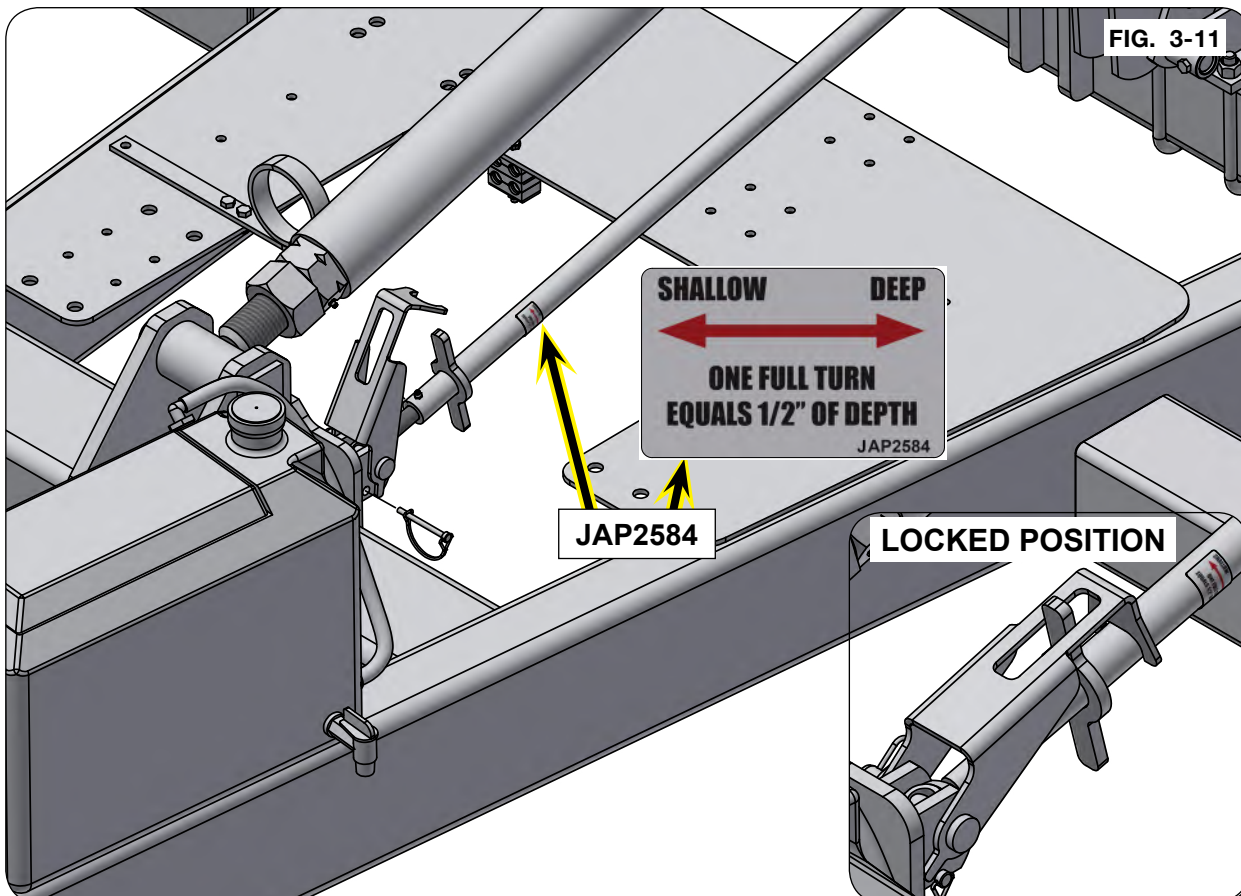

Locking Depth Adjustment Linkage

1. Rotate depth control adjuster latch over handle and lock in place with 1/4" x 2" lynch pin (JBP3376).

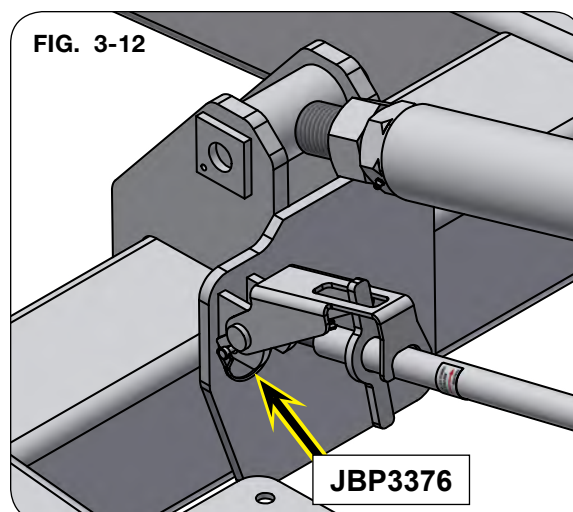

Hydraulic System Charging

WARNING

- ALWAYS RELIEVE HYDRAULIC SYSTEM PRESSURE BEFORE DISCONNECTING HOSES FROM TRACTOR OR SERVICING HYDRAULIC SYSTEM. SEE TRACTOR OPERATOR'S MANUAL FOR PROPER PROCEDURES.
- HYDRAULIC SYSTEM MUST BE PURGED OF AIR BEFORE OPERATING TO PREVENT SERIOUS INJURY OR DEATH.
- HIGH-PRESSURE FLUIDS CAN PENETRATE THE SKIN AND CAUSE SERIOUS INJURY OR DEATH. USE CARDBOARD OR WOOD TO DETECT LEAKS IN THE HYDRAULIC SYSTEM. SEEK MEDICAL TREATMENT IMMEDIATELY IF INJURED BY HIGH-PRESSURE FLUIDS.

NOTE: Refer to SETUP section for purging process.

Connecting Hydraulic Hoses to Tractor

1. Connect the hydraulic hoses to the tractor remote couplers. The 1/2" hoses supply oil to the wheel lift cylinders. The 3/8" hoses supply oil to the wing cylinders. Mark hose pairs with paint or tape. Mark hoses so that they are plugged in correctly each time.
2. Hook implement to tractor. Connect the hydraulic lines to tractor ports.

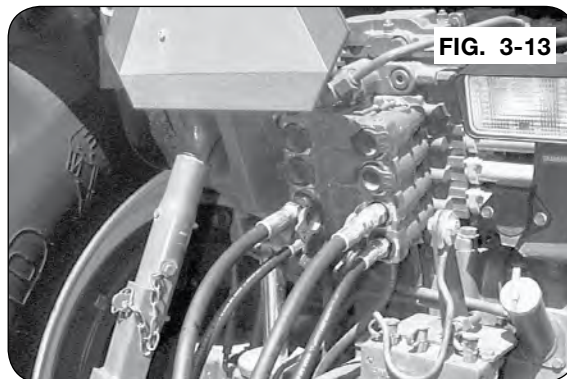

GENERIC EXAMPLE

Folding Toolbar

NOTE: Always fold and unfold with the applicator in the fully raised position.

1. Fold slowly! Check hoses, fittings and row mountings for folding interference or leaks.

FIG. 3-14



Secondary Wing Latch

1. Mechanism must swing freely in order to operate properly. Installed position must be squared with frame to allow maximum freedom of movement. Keep soil and debris from area to allow maximum movement.

NOTE: After seasonal storage, check wing latch for freedom of movement.

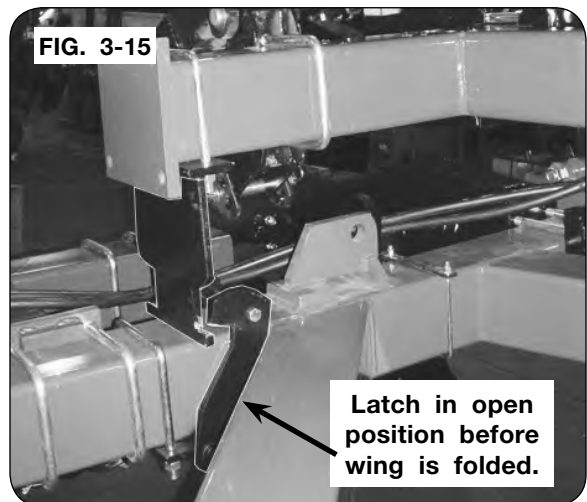

Nurse Tank Hitch

NOTE: This nurse tank hitch has a towing capacity of 25,000 lbs. gross vehicle weight.

1. Nurse tank hitch can be retracted and moved from side to side for easy hookup. Hitch will automatically lock in the extended position.

NOTE: Periodically check latch mechanism to ensure proper latching in the extended position.

2. Mechanism must swing freely in order to operate properly. Installed position must be squared with frame to allow maximum freedom of movement. Keep soil and debris from area to allow maximum movement.

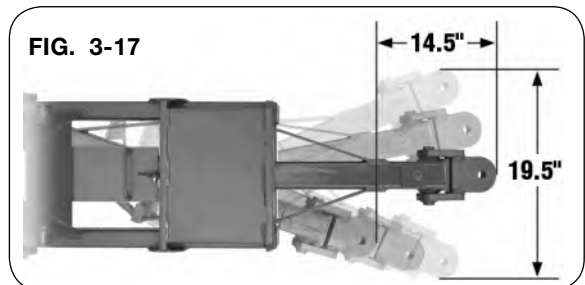
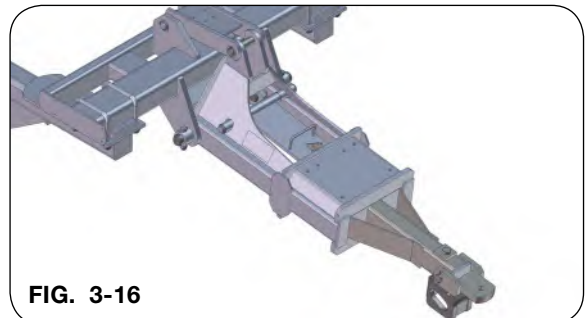

Anhydrous Ammonia Operating Instructions** DANGER**

- EXPOSURE TO ANHYDROUS AMMONIA (NH₃) WILL CAUSE SERIOUS INJURY OR DEATH.
 - AVOID BREATHING NH₃ VAPORS. ALWAYS REMAIN UPWIND WHEN WORKING ON NH₃ SYSTEM.
 - IMMEDIATELY FLUSH EXPOSED AREAS WITH CLEAN WATER AND SEEK MEDICAL TREATMENT.
 - ALWAYS WEAR PERSONAL PROTECTIVE EQUIPMENT (PPE) WHEN WORKING WITH OR NEAR NH₃. THIS INCLUDES BUT IS NOT LIMITED TO APPROPRIATE GAUNTLET STYLE GLOVES, INDIRECT VENT CHEMICAL SPLASH GOGGLES, SHOES, SOCKS, LONG SLEEVED SHIRT AND LONG PANTS.

- EXPOSURE TO ANHYDROUS AMMONIA (NH₃) WILL CAUSE SERIOUS INJURY OR DEATH. ONLY OPEN A NURSE TANK VALVE DURING APPLICATION. DO NOT TRANSPORT, PARK, OR LEAVE THE APPLICATOR UNATTENDED WITH THE VALVE OPEN.

 WARNING

- POSITION YOUR BODY AWAY FROM THE BLEED VALVE EXIT HOLE TO AVOID CONTACT WITH ANHYDROUS AMMONIA WHEN BLEED VALVE IS OPENED. CONTACT WITH EYES AND SKIN WILL CAUSE SEVERE CHEMICAL BURNS.

- AVOID BREATHING AMMONIA VAPORS. CLEAR ALL PERSONNEL FROM THE AREA BEFORE OPENING SYSTEM. INHALATION OF VAPORS WILL IRRITATE OR DAMAGE RESPIRATORY TRACT AND LUNGS, RESULTING IN INJURY OR DEATH.

IMPORTANT

- *Attend Anhydrous Ammonia Safety Training Class Before Operating This Equipment.*

NOTE: In case of exposure, have a minimum of 5 gallons of flushing water available at all times.

Anhydrous Ammonia Operating Instructions (continued)

Checking System

With personal protective equipment in place, visually inspect the toolbar and system components for integrity, including hoses that may be subject to inadvertent contact with structural surfaces resulting in premature exterior hose deterioration.

Connecting Nurse Tank

NOTE: See “Coupler Operations” in MAINTENANCE section for instructions.

Hitch the nurse tank to the applicator using a hitch pin with safety lock. Attach the wagon tongue transport chains to the hitch at the provided chain loops.

When coupling a nurse tank and supply line hose to the applicator for the first time, perform a test turn in both directions with the tank valve closed to verify sufficient slack in the hose allowing free articulation. Do not allow hose to contact the wagon tongue or any other components during movement.

When ready to begin application, with PPE in place and standing upwind, slowly open supply line valves.

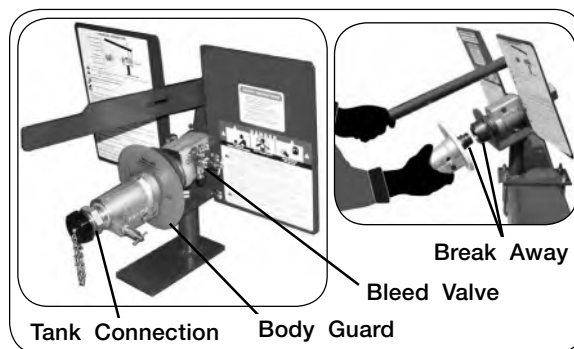

Anhydrous Ammonia Operating Instructions (continued)

Orifice Block Setting

To minimize the amount of ammonia going out the dump lines, follow the chart below to determine the dump orifice hose barb to use and install. The chart is based on GPM, gallons per minute. Use the formula below to determine your GPM then refer to the chart for the recommended dump orifice hose barb needed for your application.

Toolbar width in feet X speed X actual lbs. N per acre X .1212 ÷ .82 ÷ 5.14 ÷ 60 = GPM

1-10 GPM	11-20 GPM	21 and UP GPM	N-Serve Users
A	B	C	D

NOTE: “D” orifice is only for users having problems with N-serve plugging up the heat exchanger.

TIP: If you find that your rate does not balance out, try changing the orifice to the next larger size orifice.

To set or change the orifice size, loosen the wing nut slightly, then turn the orifice disk to the desired orifice letter by looking into the sight hole then tighten the wing nut firmly.

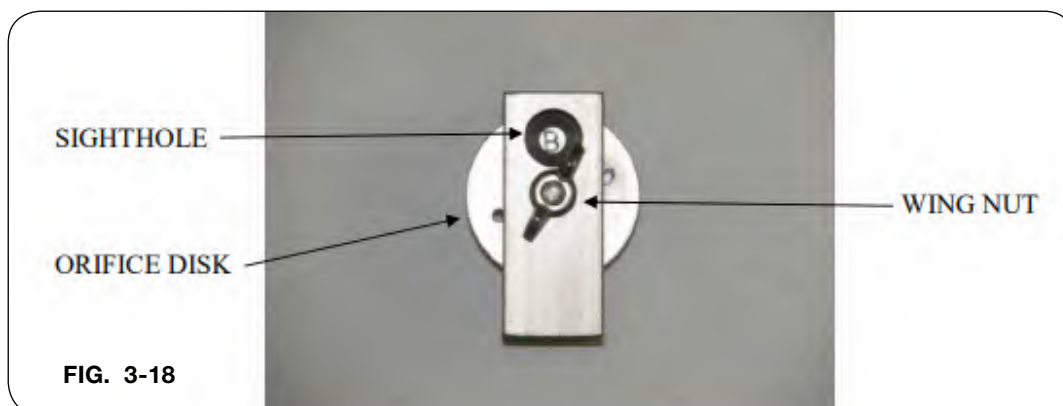

Anhydrous Ammonia Operating Instructions (continued)

Disconnecting Nurse Tank

⚠ DANGER

- EXPOSURE TO ANHYDROUS AMMONIA (NH₃) WILL CAUSE SERIOUS INJURY OR DEATH.
 - AVOID BREATHING NH₃ VAPORS. ALWAYS REMAIN UPWIND WHEN WORKING ON NH₃ SYSTEM.
 - IMMEDIATELY FLUSH EXPOSED AREAS WITH CLEAN WATER AND SEEK MEDICAL TREATMENT.
 - ALWAYS WEAR PERSONAL PROTECTIVE EQUIPMENT (PPE) WHEN WORKING WITH OR NEAR NH₃. THIS INCLUDES BUT IS NOT LIMITED TO APPROPRIATE GAUNTLET STYLE GLOVES, INDIRECT VENT CHEMICAL SPLASH GOGGLES, SHOES, SOCKS, LONG SLEEVED SHIRT AND LONG PANTS.
-
- EXPOSURE TO ANHYDROUS AMMONIA (NH₃) WILL CAUSE SERIOUS INJURY OR DEATH. ONLY OPEN A NURSE TANK VALVE DURING APPLICATION. DO NOT TRANSPORT, PARK, OR LEAVE THE APPLICATOR UNATTENDED WITH THE VALVE OPEN.

⚠ CAUTION

- FIFTH WHEEL STYLE RUNNING GEAR FRONT AXLES MAY INADVERTENTLY ROTATE IN UNEVEN SOIL CONDITIONS WHEN THE HITCH PIN IS PULLED CAUSING THE TONGUE TO COME INTO CONTACT AND POTENTIALLY INJURING THE OPERATOR.
-
1. Park applicator on a firm, level surface with operating station upwind and beginning at the tank, fully close all supply hose valves.
 2. While remaining upwind, slowly open coupler bleed valve to release pressure from the coupler. (FIG. 3-19)
 3. Once pressure is completely bled, disconnect supply hose. Store hose safely to protect hose from damage during transport.
 4. Block the wheels on nurse tank wagon and disconnect from applicator hitch.

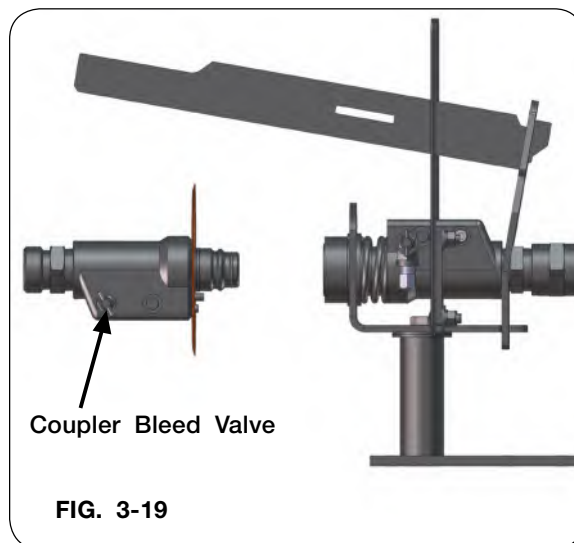

Clean Water Tank

Change water daily to provide fresh clean water to flush exposed skin or eyes. Drain water daily in cold temperatures to prevent freezing and bursting tank.

In case of exposure to anhydrous ammonia, open faucet or pull top end of hose loose to flush exposed part of body. Remove contaminated clothes as soon as possible. Seek medical attention.

NOTE: Clean Water Tank placement will depend on row spacing.



FIG. 3-20

DiscCover Sealer (Options)

See manual #J04000040 for complete operating procedures.

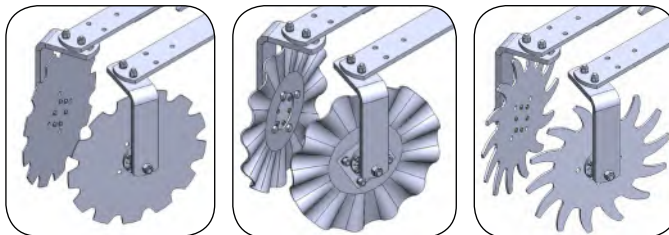

Torsion Arm Basket (Options)

See manual #J04000027 for complete operating procedures.

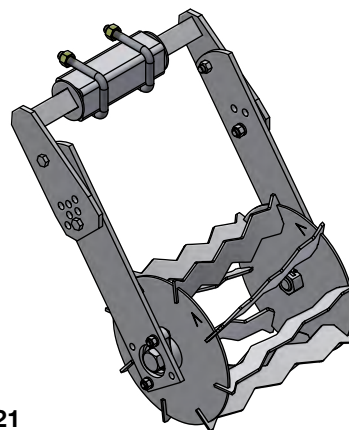
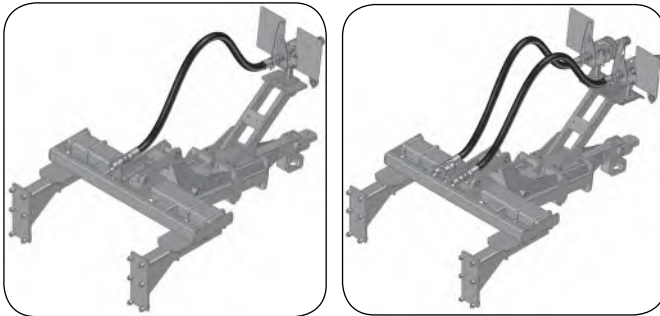

FIG. 3-21

SuperShooter (Options)

See manual #J04000041 or J04000026 for complete operating procedures.



SUPERSHOOTER III
1 1/4" NPT OR 1 1/2" NPT
(MANUAL #J04000041)

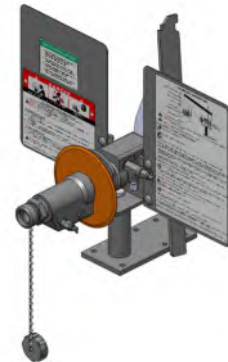

SUPERSHOOTER III
COUPLER
BODYGUARD III
(MANUAL #J04000026)

MaxPac AR700 (Options)

See manual #J04000028 for complete operating procedures.

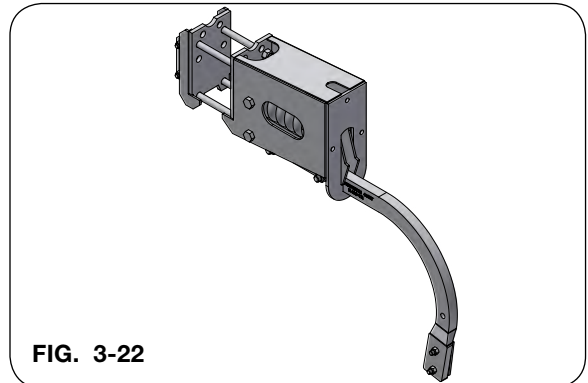

FIG. 3-22

Residue Manager (Options)

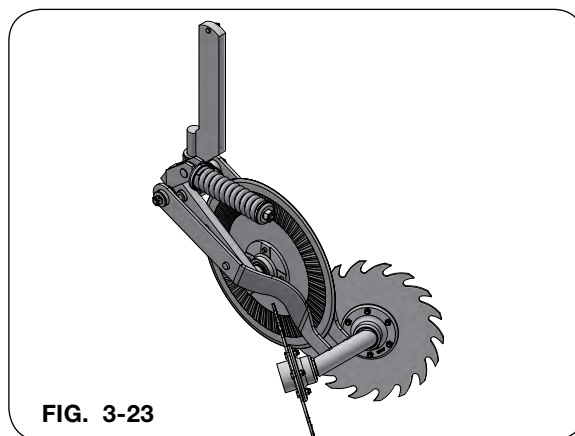

FIG. 3-23

Operational Guide For Various Residue Situations

Coulter Blades For All Crops

- 3"-4" Deep (make sure hub is not running in the ground)
- If blades are new or being used for the first time in a season, or if residue is hair pinning, sharpening each blade will assist in cutting during the first few acres of operation. After the first few acres, blades will self-sharpen.

Beans (Soy or Pinto)

Residue Managers – Light pressure setting (particularly in light soils)

Shank Depth – Minimum 4" deep from ground level (optimum depth for fertilizer placement is 6"-8")

Sealer Blade Pitch – Determined by soil type and season in soybean residue

Sealer Blade Down Pressure – Determined by soil type and season in this residue

Basket Pressure – Determined by soil type and season in this residue

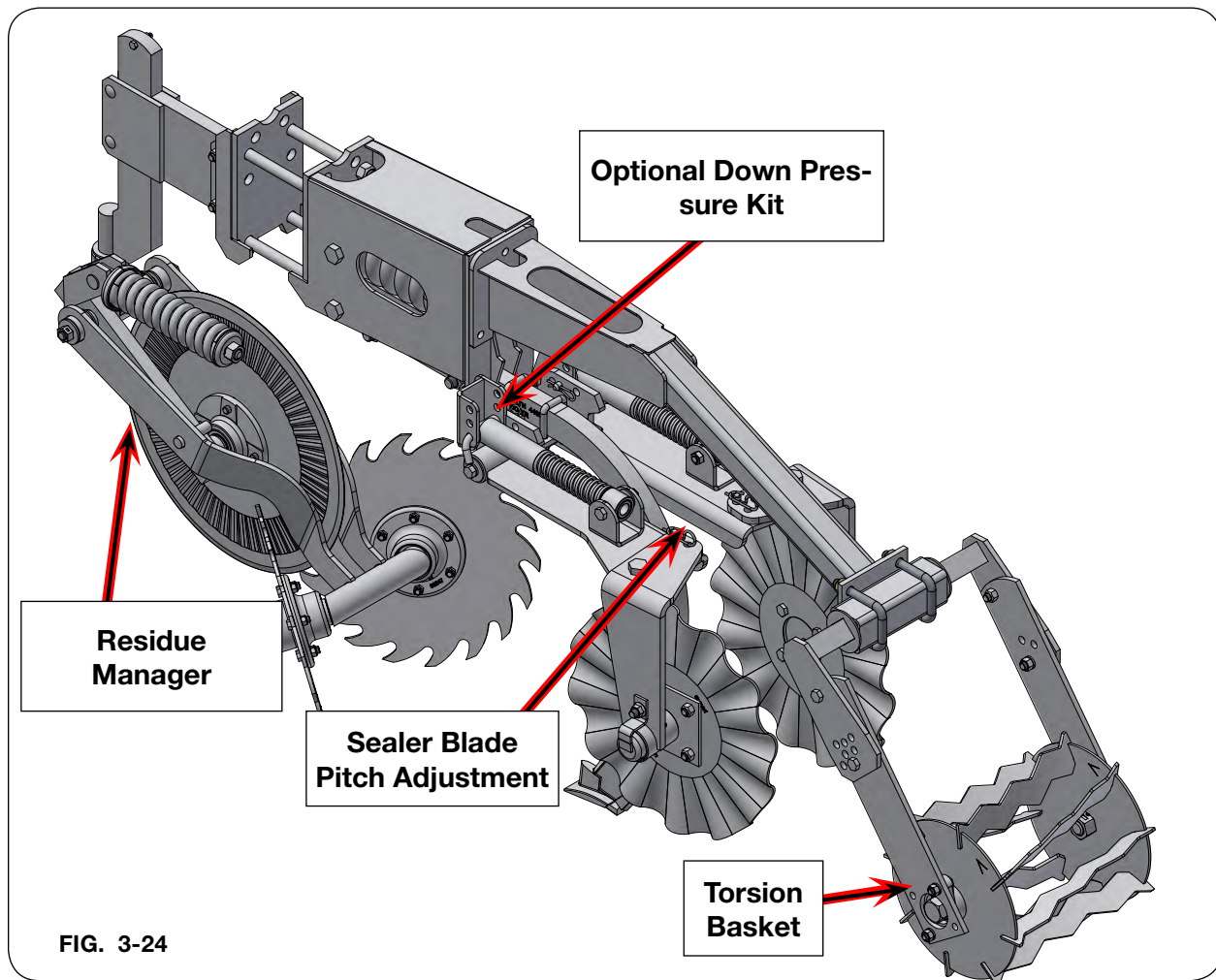

Operational Guide For Various Residue Situations (continued)

Corn

For best results follow these operating recommendations:

- Leaving standing stalks in the field when harvesting (about knee high) is preferable to shredding the residue
- Corn in one year rotation: Row units on the machine should be operated between last year's corn rows (split last year's rows)
- Corn in two plus years rotation: Row units on the machine should be operated 7.5" to one side of last year's corn row (RTK guidance recommended)
- Silage: Row units on the machine should be operated at least 7.5" off of any corn row where root ball masses remain mostly intact

Under 250 Bushel In One Year Corn/Bean Rotation

Residue Managers – Heavy pressure setting

Shank Depth – Minimum 4" deep from ground level (optimum depth for fertilizer placement is 6"-8")

Sealer Blade Pitch – Blades should be even in pitch and backs of the blades should be at least 8" apart

Sealer Blade Down Pressure – Determined by soil type and season in this residue

Basket Pressure – Determined by soil type and season in this residue

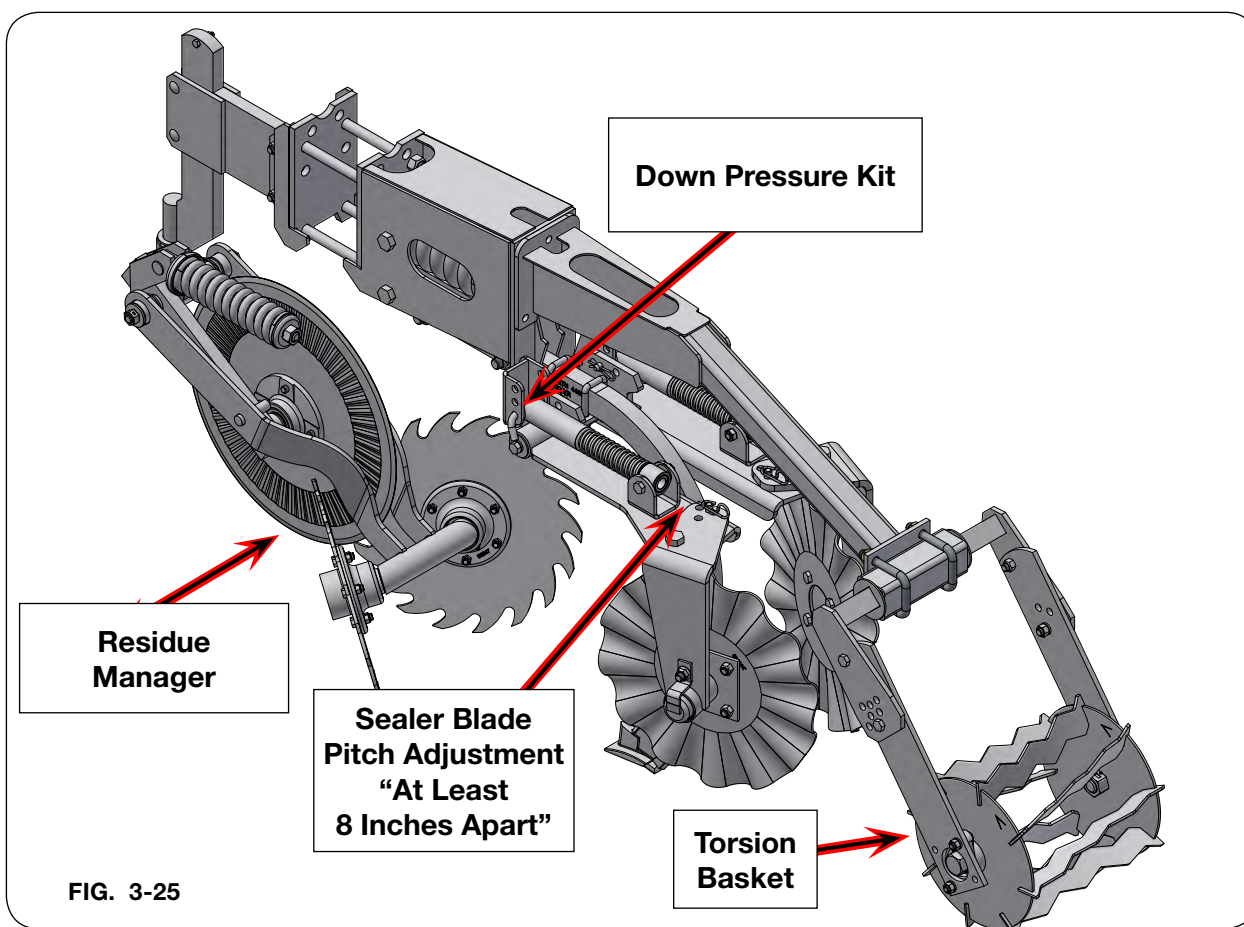

FIG. 3-25

Operational Guide For Various Residue Situations (continued)

Corn (continued)

Over 250 Bushel In One Year Corn/Bean Rotation

Residue Managers – Heavy pressure setting

Shank Depth – Minimum 4" deep from ground level (optimum depth for fertilizer placement is 6"-8")

Sealer Blade Pitch

- Left blade should be set at nearly maximum pitch
- Right blade should be set at about half pitch when compared to the left blade

Sealer Blade Down Pressure – Down Pressure Kits are recommended for this residue situation

Basket Pressure – Running a basket is recommended for this residue situation.

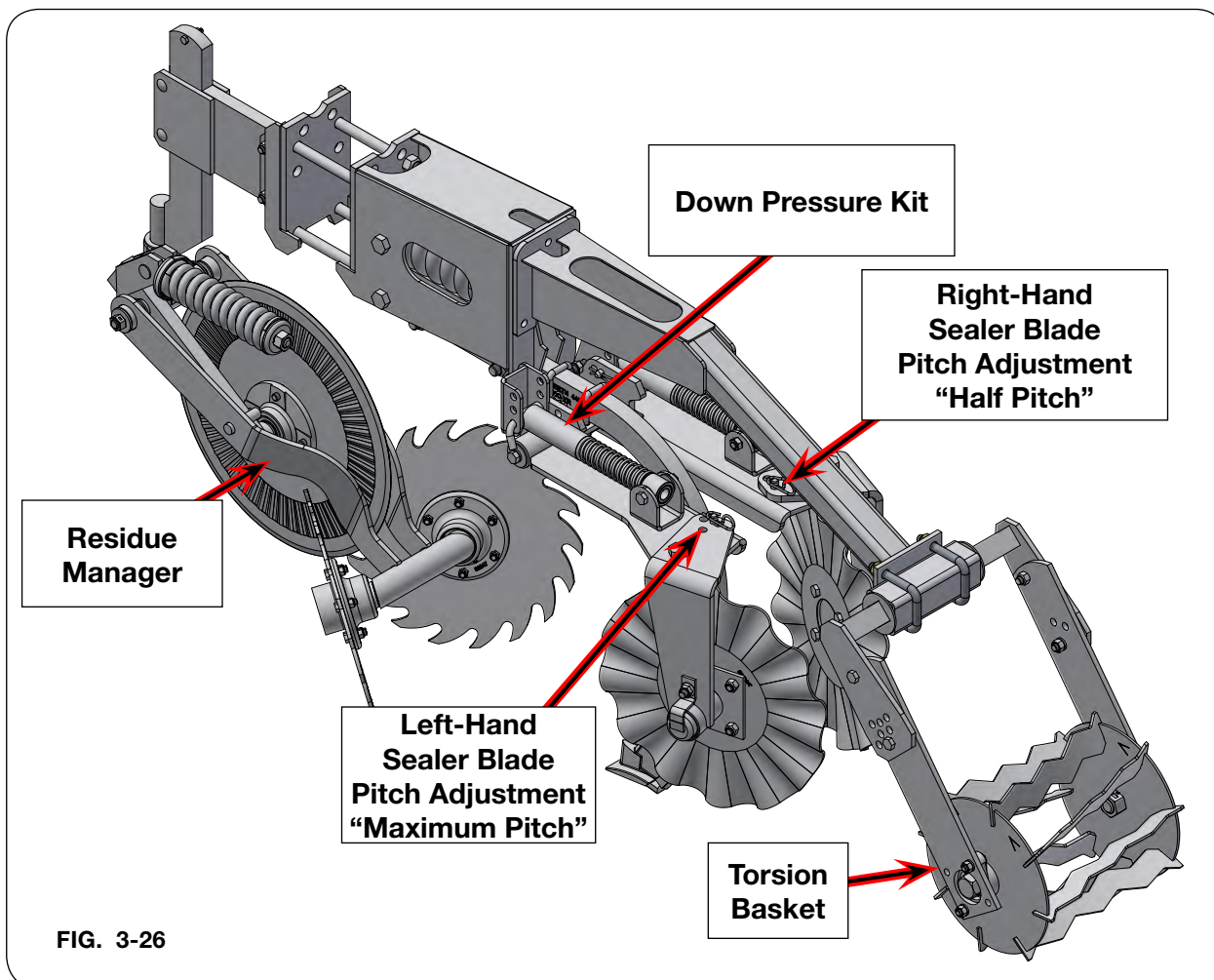

Operational Guide For Various Residue Situations (continued)

Corn (continued)

Under 250 Bushel In 2+ Years Corn Rotation

Residue Managers – Heavy pressure setting

Shank Depth – Minimum 4" deep from ground level (optimum depth for fertilizer placement is 6"-8")

Sealer Blade Pitch – Blades should be even in pitch and backs of the blades should be at least 10" apart

Sealer Blade Down Pressure – Down Pressure Kits are recommended for this residue situation

Basket Pressure – Determined by soil type and season in this residue

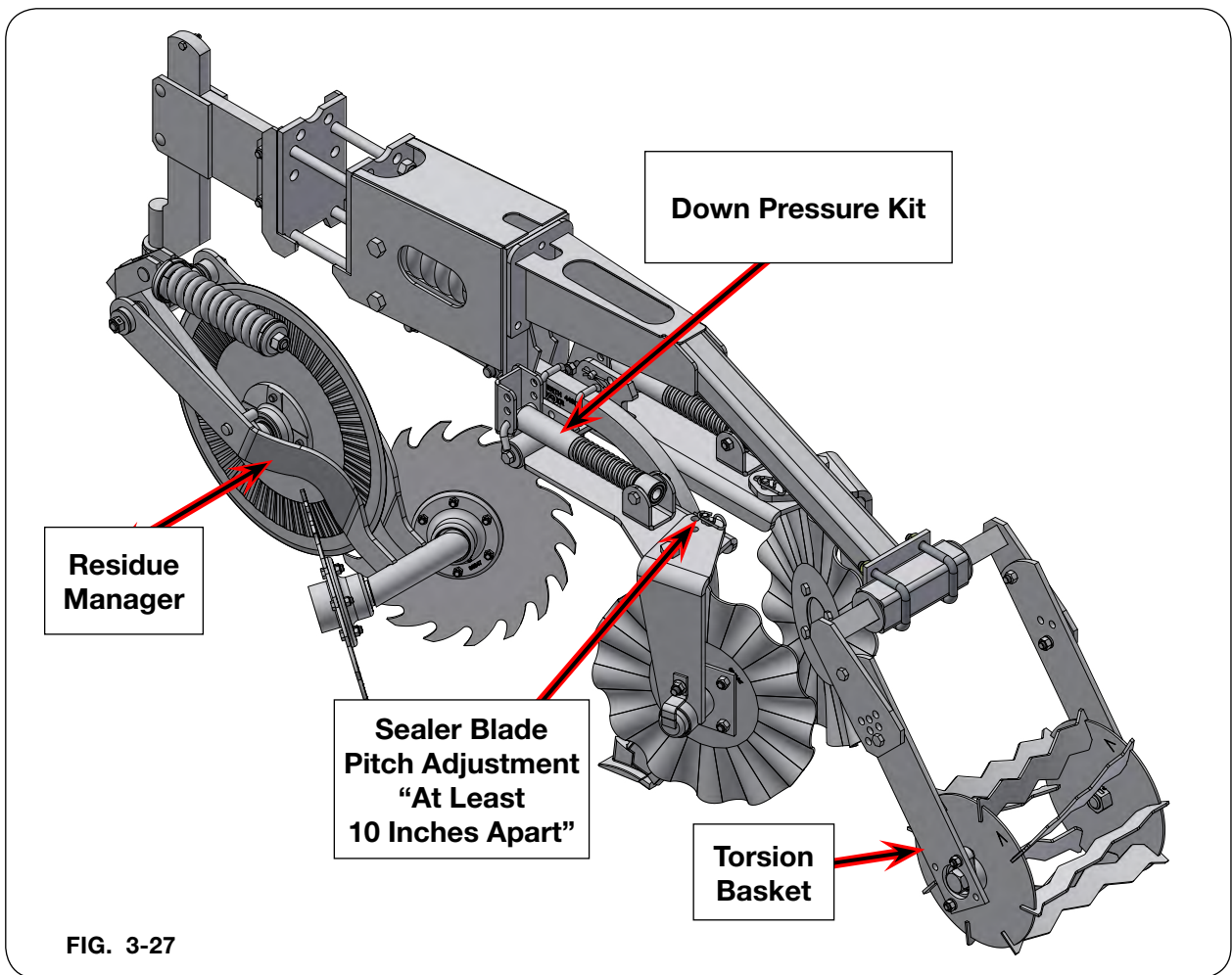

Operational Guide For Various Residue Situations (continued)

Corn (continued)

Over 250 Bushel In 2+ Years Corn Rotation

Residue Managers – Heavy pressure setting

Shank Depth – Minimum 4" deep from ground level (optimum depth for fertilizer placement is 6"-8")

Sealer Blade Pitch

- Left blade should be set at nearly maximum pitch
- Right blade should be set at about half pitch when compared to the left blade

Sealer Blade Down Pressure – Down Pressure Kits are recommended for this residue situation

Basket Pressure – Running a basket is recommended for this residue situation.

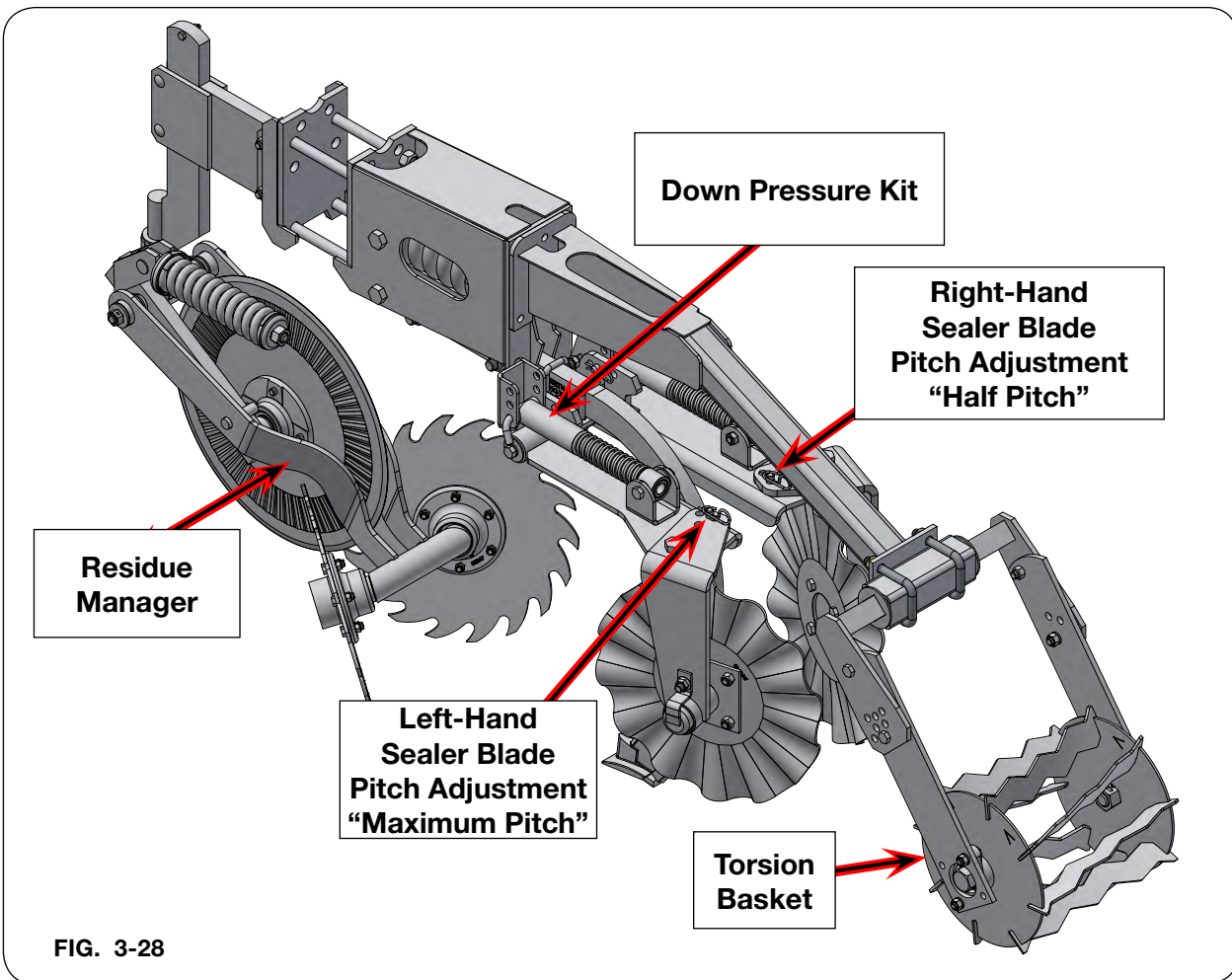

FIG. 3-28

Operational Guide For Various Residue Situations (continued)

Corn (continued)

Silage

Residue Managers - Light pressure setting (particularly in light soils)

Shank Depth - Minimum 4" deep from ground level (optimum depth for fertilizer placement is 6"-8")

Sealer Blade Pitch - Determined by soil type and season in this residue

Sealer Blade Down Pressure - Determined by soil type and season in this residue

Basket Pressure - Determined by soil type and season in this residue

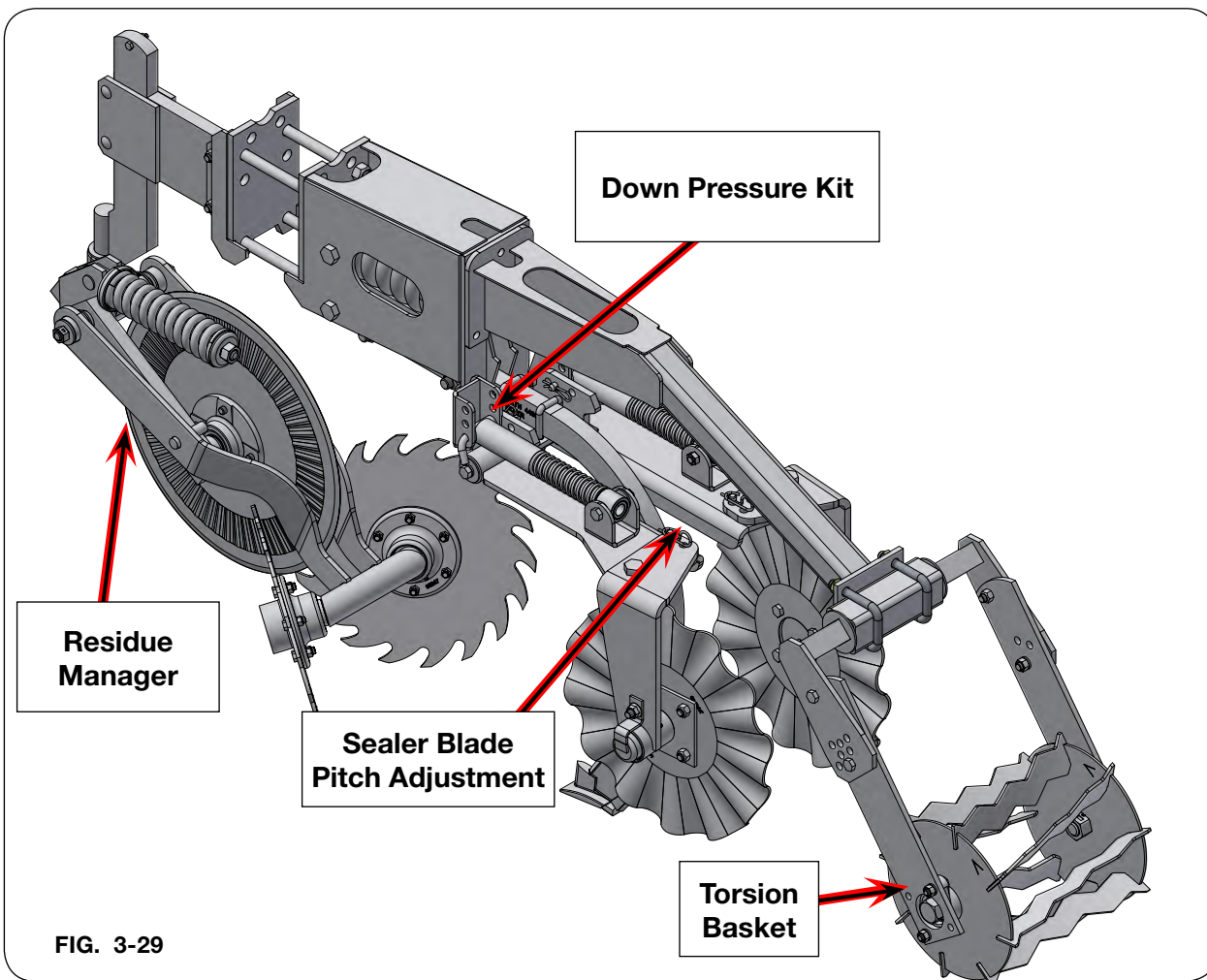

Operational Guide For Various Residue Situations (continued)

Cover Crop (Live or Residue)

Residue Managers – Heavy pressure setting

Shank Depth – Minimum 4" deep from ground level (optimum depth for fertilizer placement is 6"-8")

Sealer Blade Pitch – Blades should be even in pitch and backs of the blades should be at least 8" apart

Sealer Blade Down Pressure – Down Pressure Kit recommended in this residue situation

Basket Pressure – Determined by soil type and season in this residue

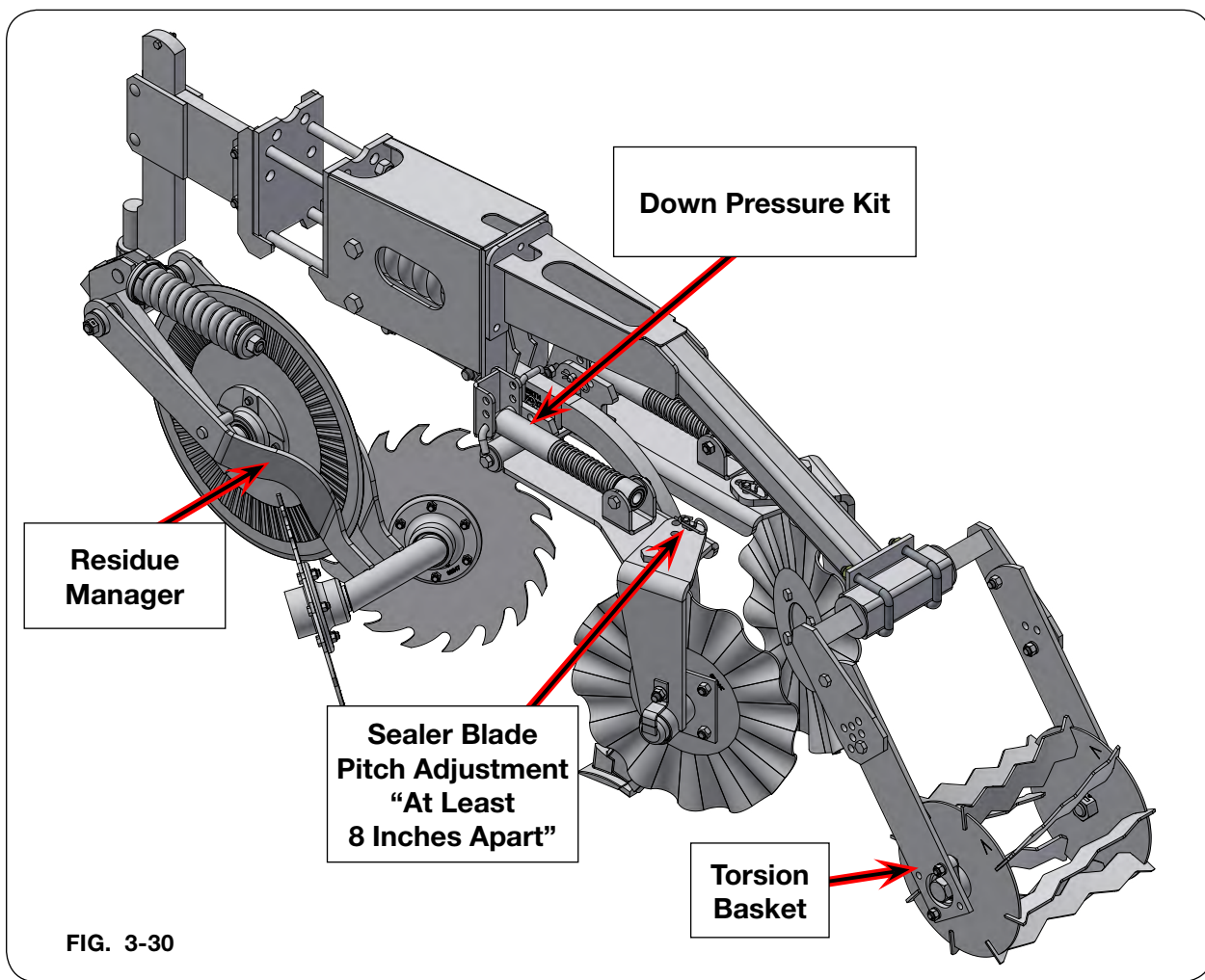

Operational Guide For Various Residue Situations (continued)

Sugar Beets

Residue Managers - Light pressure setting (particularly in light soils)

Shank Depth - Minimum 4" deep from ground level (optimum depth for fertilizer placement is 6"-8")

Sealer Blade Pitch - Determined by soil type and season in this residue

Sealer Blade Down Pressure - Determined by soil type and season in this residue

Basket Pressure - Determined by soil type and season in this residue

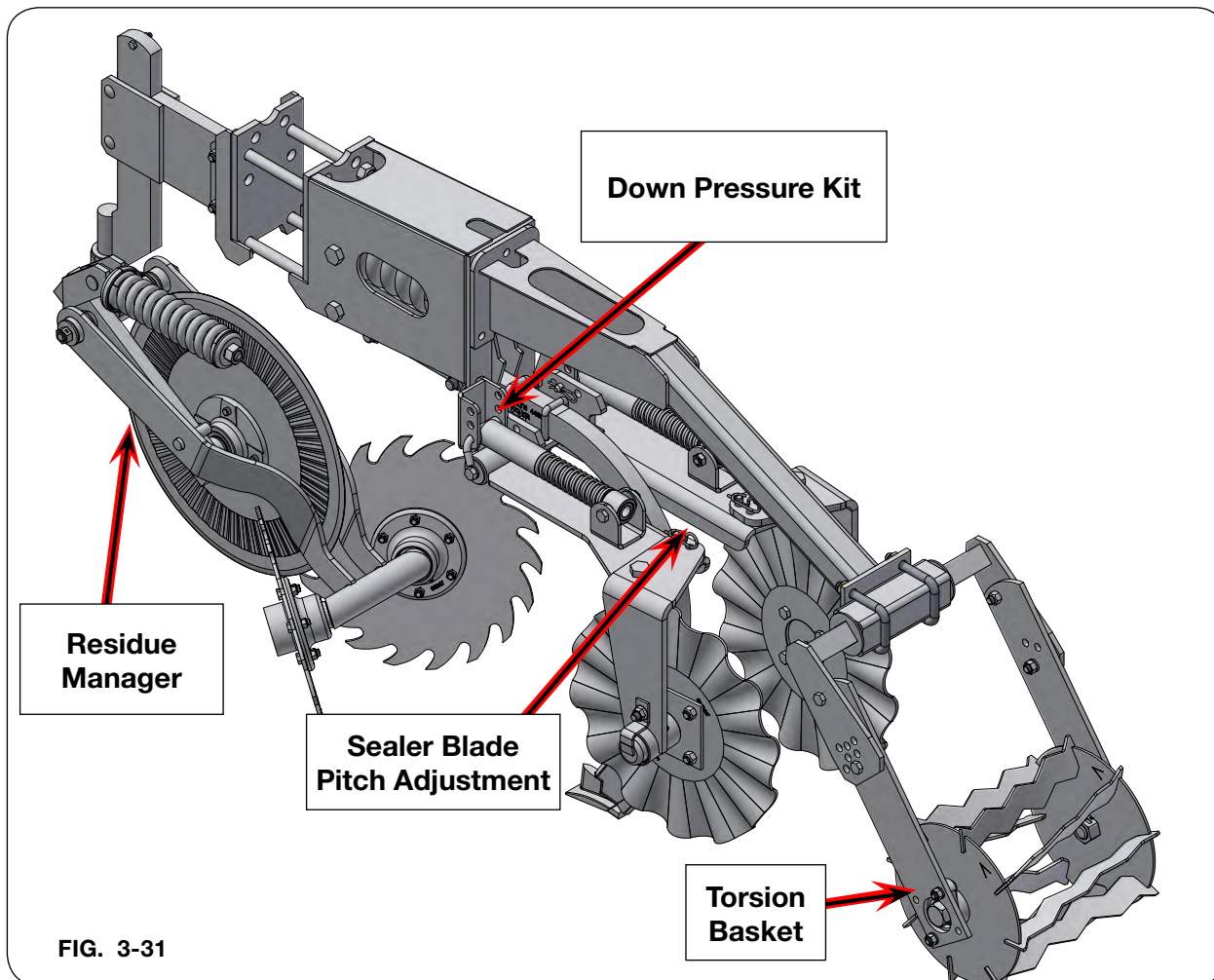

Operational Guide For Various Residue Situations (continued)

Wheat & Other Small Grain

Residue Managers – Heavy pressure setting

Shank Depth – Minimum 4” deep from ground level (optimum depth for fertilizer placement is 6”-8”)

Sealer Blade Pitch – Blades should be even in pitch and backs of the blades should be at least 8” apart

Sealer Blade Down Pressure – Down Pressure Kit recommended in this residue situation

Basket Pressure – Determined by soil type and season in this residue

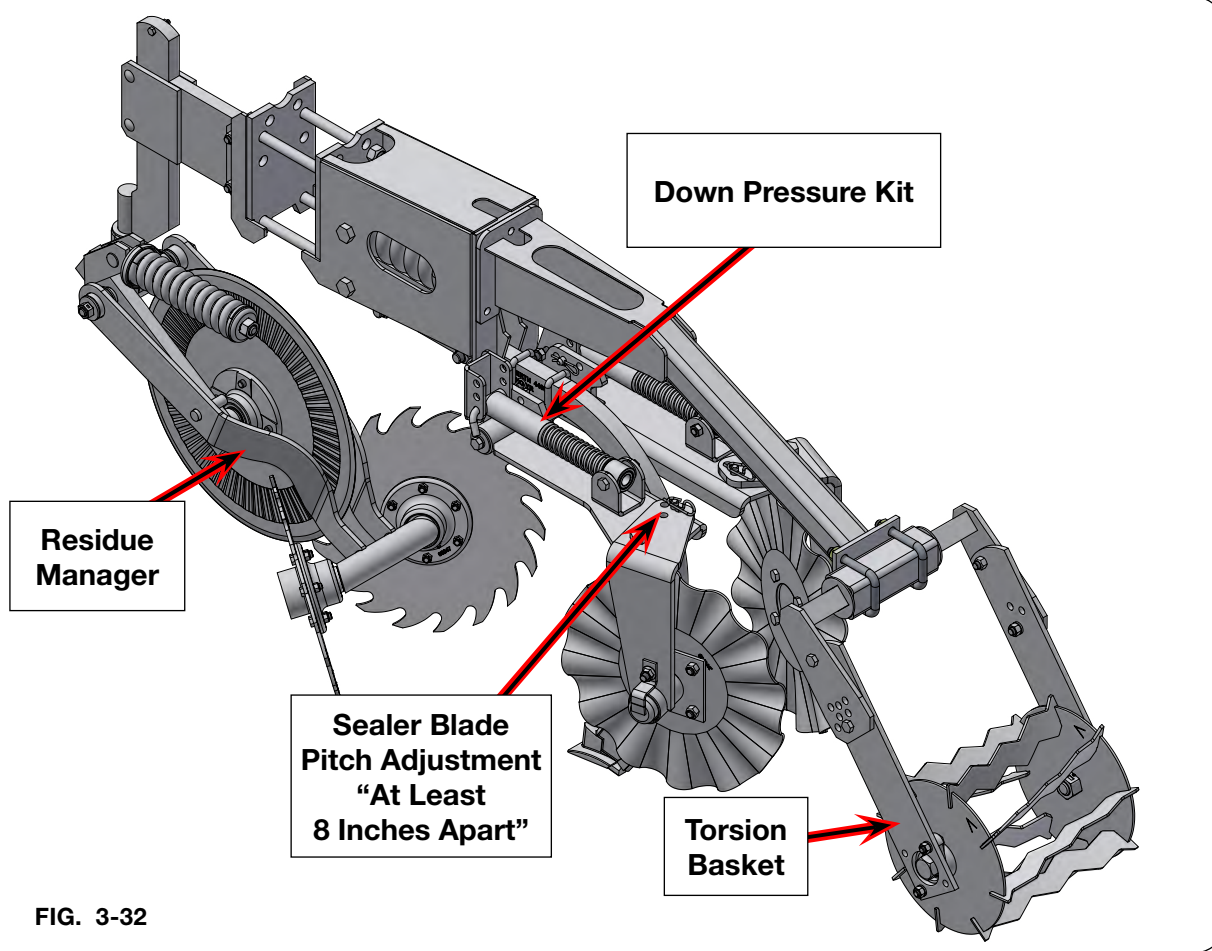
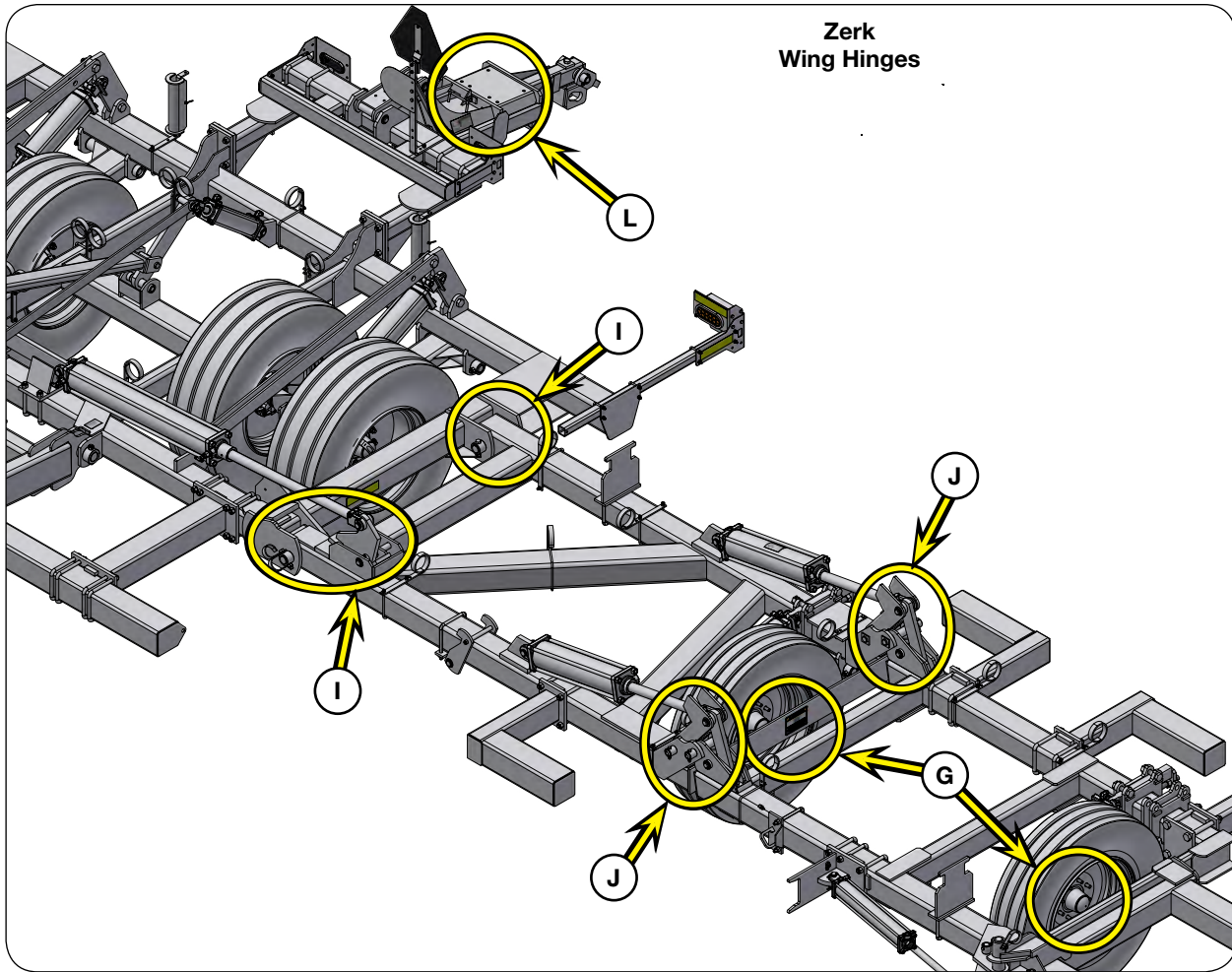
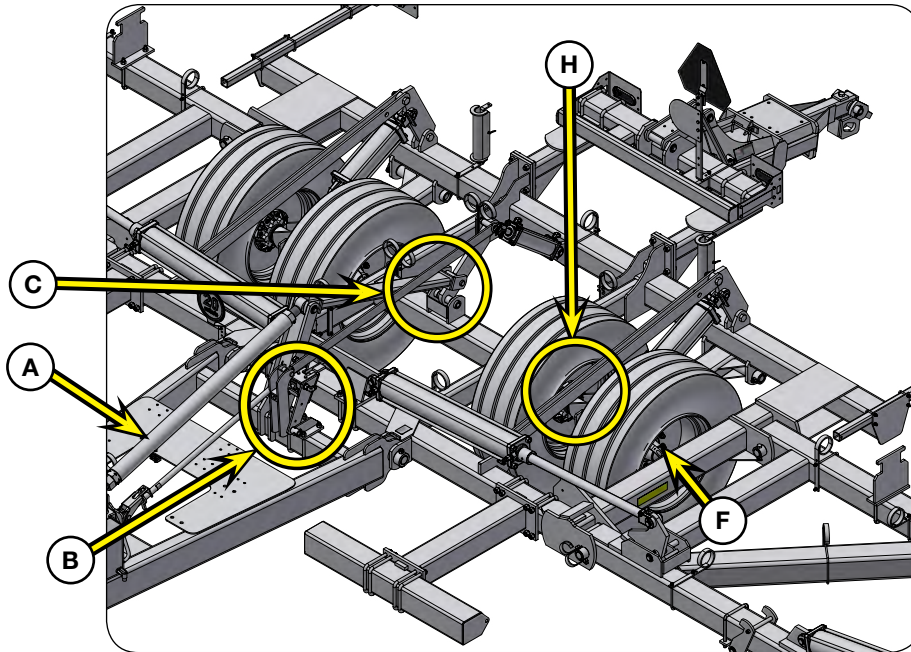

FIG. 3-32

Section IV Maintenance

Lubrication.....	4-2
Hydraulics.....	4-4
Purging A Hydraulic System	4-4
6120 Maintenance	4-5
Seasonal Storage.....	4-6
NH3 Bleed Procedure	4-7
Coupler Operations.....	4-10
Electrical Layout - AgLeader Rate Controller.....	4-12
Electrical Layout - Raven 450 Rate Controller.....	4-13
Electrical Layout - Lighting	4-14
Schematics - Electrical.....	4-15
Electrical Harness - Limit Switch Assembly (416395).....	4-15
Electrical Harness - 450 Console Controller (9007549).....	4-16
Electrical Harness - 12 Ft. Extension (9503392) - For On/Off Valve	4-17
Electrical Harness - 24 Ft. Extension (9503393) - For On/Off Valve	4-17
Electrical Harness - Console 10 Ft. (9503395) - Transducer to Console.....	4-18
Electrical Harness - 16 Pin Console to 47 Pin Connector (9503396).....	4-19
Electrical Harness - RCM Accu-Flow - 3 Section (9504612).....	4-20
Electrical Harness - RCM Accu-Flow - 6 Section (9504613).....	4-21
Electrical Harness - 16 Ft. Front IBIC (9505086).....	4-22
Electrical Harness - Flow Control Cable (9505087).....	4-23
Electrical Harness - Swath Control - 6 Section (9505088)	4-24
Electrical Harness - ISOBUS Breakout (9505089)	4-25
Electrical Harness - Local CAN Breakout (9505090).....	4-26
Electrical Harness - ISO Switchbox Metripack Tee (9505092)	4-27
Electrical Harness - ISO Active Imp Termination (9505093).....	4-27
Electrical Harness - CAN Implement Switch Cable (9505100).....	4-28
Electrical Harness - Main 33' (JAP3221).....	4-28
Electrical Harness - Rear 27' (JAP3222)	4-29
Electrical Harness - AG Plug to RV Socket (JAP3223).....	4-29
Wheel, Hub and Spindle Disassembly and Assembly	4-30
Wheels and Tires.....	4-32
Wheel Nut Torque Requirements.....	4-32
Tire Pressure	4-33
Tire Warranty	4-34
Complete Torque Chart.....	4-35
Hydraulic Fittings - Torque and Installation.....	4-37
NH3 Fittings - Torque and Installation.....	4-39

Lubrication



Lubrication (continued)

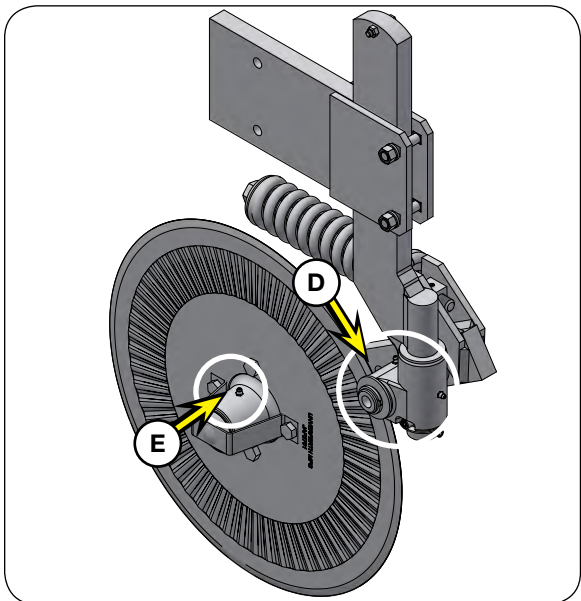

To keep your applicator in top operating condition and to assure its proper performance and reliability for a long period of time, periodic inspection and lubrication is a must.

Use EP-2 lubricant at the locations described in the chart.

All exposed cylinder rods should be coated with grease before seasonal storage to prevent rusting. Remove depth collars and lubricate exposed cylinder rods.

After seasonal storage, check wing latch for freedom of movement.

The lubrication locations and recommended schedule are as follows:

ITEM	DESCRIPTION	POINT	QTY.	HOURS
A	Depth Control Turnbuckle Assembly*	2	2 Shots	50 Hours
B	Stop Arm with Plunger Assembly	1	1 Shot	Weekly
C	Tongue Cylinder Arm Linkage	4	1 Shot	Weekly
D	Coulters Arm Pivot	2	2 Shots	Weekly
E	Coulters Hub	-	10 Shots	Once Every Season
F	Main Frame Transport Wheel Hub	2	Repack	Once Every Season
G	Wing Gauge Wheel Hub	4	Repack	Once Every Season
H	Main Frame Gauge Wheel Pivot	8	5 Shots	Weekly
I	Main Frame to Primary Wing Hinge	4	5 Shots	Weekly
J	Primary Wing to Secondary Wing Hinge & Linkage	6	5 Shots	Weekly
K	Hitch	2	2 Shots	Weekly
L	Nurse Tank - Under Hitch	1	2 Shots	Weekly

***NOTE - ITEM A:** Turn adjustable link two full turns in each direction to ensure threads do not seize.

Hydraulics

Purging A Hydraulic System

WARNING

- RELIEVE HYDRAULIC SYSTEM OF ALL PRESSURE BEFORE ADJUSTING OR SERVICING. SEE TRACTOR OPERATOR'S MANUAL FOR PROPER PROCEDURES.

 - HIGH-PRESSURE FLUIDS CAN PENETRATE THE SKIN AND CAUSE SERIOUS INJURY OR DEATH. SEEK MEDICAL TREATMENT IMMEDIATELY IF INJURED BY HIGH-PRESSURE FLUIDS. USE CARDBOARD OR WOOD TO DETECT LEAKS IN THE HYDRAULIC SYSTEM.

 - EYE PROTECTION AND OTHER APPROPRIATE PERSONAL PROTECTIVE EQUIPMENT MUST BE WORN WHILE SERVICING IMPLEMENT.

1. Purge air from system as follows:
 - A. Clear all personnel and objects from the area, including where the machine will have full range of motion during the hydraulic movement. Remove transport locks from the machine.
 - B. Pressurize the system and maintain the system at full pressure for at least 5 seconds after the cylinder rods stop moving, or hydraulic motors have completed the required movement. Check that all movements are fully completed.
 - C. Check oil reservoir in the hydraulic power source and refill as needed.
 - D. Pressurize the system again to reverse the motion of step B. Maintain pressure on the system for at least 5 seconds after the cylinder rods stop moving, or hydraulic motors have completed the required movement. Check that all movements are fully completed.
 - E. Check for hydraulic oil leaks using cardboard or wood. Tighten connections according to directions in the Torque Specifications in the MAINTENANCE section.
 - F. Repeat steps in B, C, D, and E 10-12 times.

6120 Maintenance

DANGER

- **ELECTROCUTION WILL CAUSE SERIOUS INJURY OR DEATH. THE IMPLEMENT IS NOT INSULATED. KEEP AWAY FROM ALL ELECTRICAL LINES AND DEVICES. ELECTROCUTION CAN OCCUR WITHOUT DIRECT CONTACT.**
-

WARNING

- **TIPPING OR MOVEMENT OF THE MACHINE CAN CAUSE SERIOUS INJURY OR DEATH. BE SURE MACHINE IS SECURELY BLOCKED.**

 - **EYE PROTECTION AND OTHER APPROPRIATE PERSONAL PROTECTIVE EQUIPMENT MUST BE WORN WHILE SERVICING IMPLEMENT.**

 - **KEEP HANDS CLEAR OF PINCH POINT AREAS.**

 - **ALWAYS WEAR PERSONAL PROTECTIVE EQUIPMENT WHEN WORKING WITH OR NEAR CHEMICALS. THIS EQUIPMENT INCLUDES, BUT IS NOT LIMITED TO: PROTECTIVE EYE WEAR, GLOVES, SHOES, SOCKS, LONG-SLEEVED SHIRT, AND LONG PANTS. ADDITIONAL PROTECTION MAY BE REQUIRED FOR MANY TYPES OF CHEMICALS.**

 - **AVOID BREATHING SPRAY MIST OR VAPOR.**

 - **WASH HANDS BEFORE EATING, DRINKING, CHEWING GUM, OR USING TOILET.**

 - **NEW HYDRAULIC SYSTEMS OR SYSTEMS THAT HAVE BEEN MAINTAINED MUST BE PURGED OF AIR BEFORE OPERATING OR MOVING MACHINE TO PREVENT SERIOUS INJURY OR DEATH.**
-

CAUTION

- **SHARP EDGES ON COULTER BLADES AND KNIVES CAN CAUSE SERIOUS INJURY. BE CAREFUL WHEN WORKING AROUND COULTER BLADES AND KNIVES.**
-

6120 Maintenance (continued)**Seasonal Storage**

Check coultter swivel for wear. Replace as needed. See FIG. 4-1 on next page.

Always open all valves to remove any fluids and to allow moisture to dry.

Immediately after season is finished, completely wash machine to remove corrosive fertilizer inside and out before storing. When using pressure washers maintain an adequate distance so not to force water into bearings, hydraulic seals, or electrical connections.

Repaint all areas where paint has been removed to keep rust from developing. Coat areas of coultter blades and knives, if equipped, and coultter posts with rust preventative material.

Coat exposed cylinder piston rods with rust preventative material.

Inspect machine for parts that may need to be replaced so they may be ordered in the off season.

Lubricate machine at all points outlined.

Check coultter hubs for free rotation. If blade hubs do not rotate, replace and/or pack bearings with grease. Replace coultter arm if spindle is damaged. (FIG. 4-1)

After period of unused time, unit should be unfolded and refolded to check function of hydraulic system.

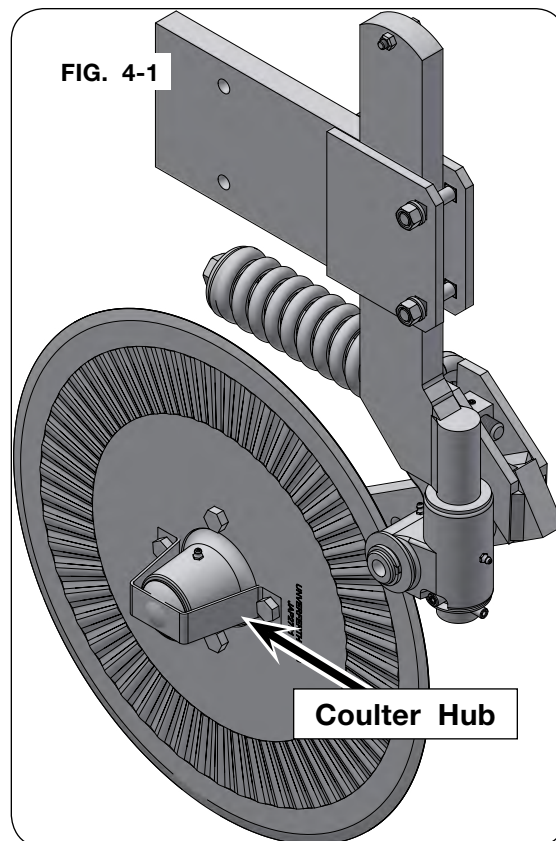

NH3 Bleed Procedure

DANGER

- ELECTROCUTION WILL CAUSE SERIOUS INJURY OR DEATH. THE IMPLEMENT IS NOT INSULATED. KEEP AWAY FROM ALL ELECTRICAL LINES AND DEVICES. ELECTROCUTION CAN OCCUR WITHOUT DIRECT CONTACT.

WARNING

- TIPPING OR MOVEMENT OF THE MACHINE CAN CAUSE SERIOUS INJURY OR DEATH. BE SURE MACHINE IS SECURELY BLOCKED.
- EYE PROTECTION AND OTHER APPROPRIATE PERSONAL PROTECTIVE EQUIPMENT MUST BE WORN WHILE SERVICING IMPLEMENT.
- KEEP HANDS CLEAR OF PINCH POINT AREAS.
- ALWAYS WEAR PERSONAL PROTECTIVE EQUIPMENT WHEN WORKING WITH OR NEAR CHEMICALS. THIS EQUIPMENT INCLUDES, BUT IS NOT LIMITED TO: PROTECTIVE EYE WEAR, GLOVES, SHOES, SOCKS, LONG-SLEEVED SHIRT, AND LONG PANTS. ADDITIONAL PROTECTION MAY BE REQUIRED FOR MANY TYPES OF CHEMICALS.
- AVOID BREATHING SPRAY MIST OR VAPOR.
- WASH HANDS BEFORE EATING, DRINKING, CHEWING GUM, OR USING TOILET.

Changing Anhydrous Tanks

1. Park the machine on a firm level surface. Ensure the machine is downwind of where you will be working on it. Lower the machine to the ground or transport stands and set the tractor parking brake.
2. Put on the appropriate PPE including long sleeve shirt, protective gloves, and chemical splash goggles. Ensure the water tank is filled.

Protective gloves: Gauntlet-style made of rubber or other material impervious to anhydrous ammonia with sufficient length to allow for cuffing and which provide thermal protection suitable for anhydrous ammonia exposure.

Chemical splash goggles: Flexible fitting chemical-protective goggles with a hooded indirect ventilation system to provide primary protection of the eyes and eye sockets from the splash of hazardous liquids. Designed to meet the requirements of ANSI Z87.1.

NH3 Bleed Procedure (continued)

3. Completely close the feed valve that is attached to the tank.



4. Completely close the hose end valve attached to the feed line going to applicator.



5. Crack the bleeder attached to the ACME coupler and allow anhydrous to bleed out.

6. Once anhydrous stops bleeding out, shake the line to make sure it is completely empty. If more gas bleeds out, allow it to finish and repeat this step.



7. Carefully loosen ACME nut and unthread slowly until the threaded hose connection is completely disconnected from the tank valve.
8. Store the ACME connector on the parking plug provided on the applicator.
9. Unhook the tank from the applicator.
10. Inspect the ACME gasket on the connectors for damage and replace if needed.
11. Hook up the next Anhydrous tank to the applicator and ensure the transport chain is attached.

NH3 Bleed Procedure (continued)

12. Unhook the ACME coupler from the parking plug.



- **DAMAGED ACME GASKETS OR LACK OF ONE COULD CAUSE INADEQUATE SEALING RESULTING IN INJURY OR DEATH**

13. Thread the ACME coupler onto the new tank.

- Always check to make sure there is a good ACME gasket seal on the tank connection.

14. Hook up the ACME coupler to the tank connection.

15. Close all bleeder valves.

16. Slowly crack open the main valve on the tank. Before opening the hose-end valve, the pressure will not reach the feed hose. Allow the pressure to equalize. Once you stop hearing flow, open the valve the rest of the way. Repeat this process for the hose-end valve on the feed line to the applicator.

NOTE: There won't be flow into the hose until the hose-end valve is opened.

17. Resume anhydrous ammonia application.

Complete Bleeding Procedure for Toolbar

- Park the unit on a firm, level surface. Ensure the potential release points for anhydrous ammonia are downwind of where you will be working. Note that some bleed valves exhaust to the applicator's vapor knives. Lower the toolbar to the ground and allow the knives to engage into the ground. Shut off the tractor and remove the ignition key.
- Put on the appropriate PPE including long-sleeve shirt, protective gloves, and chemical splash goggles. Ensure the water tank is filled.



- **ADDITIONAL PPE WOULD BE APPROPRIATE FOR ANY MAINTENANCE OR REPAIR ACTIVITIES WHICH MAY RESULT IN UNEXPECTED RELEASE OF ANHYDROUS AMMONIA (SUCH AS THE REPLACEMENT OF A SYSTEM COMPONENT OR THE RECONNECTION OF A BREAK-AWAY COUPLER). A HALF-FACE OR ESCAPE RESPIRATOR SUITABLE FOR ANHYDROUS AMMONIA WOULD PROVIDE PROTECTION AGAINST INHALATION HAZARDS.**

3. Completely close tank withdraw valve on the anhydrous tank and hose-end valve on feed line to toolbar.

4. Bleed the system down by opening the bleeder valves on applicator and supply hoses.

5. Allow the valves to completely bleed. Shake all hoses to ensure they are completely bled.

Coupler Operations



- EXPOSURE TO ANHYDROUS AMMONIA (NH₃) WILL CAUSE SERIOUS INJURY OR DEATH.
 - AVOID BREATHING NH₃ VAPORS. ALWAYS REMAIN UPWIND WHEN WORKING ON NH₃ SYSTEM.
 - IMMEDIATELY FLUSH EXPOSED AREAS WITH CLEAN WATER AND SEEK MEDICAL TREATMENT.
 - ALWAYS WEAR PERSONAL PROTECTIVE EQUIPMENT (PPE) WHEN WORKING WITH OR NEAR NH₃. THIS INCLUDES BUT IS NOT LIMITED TO APPROPRIATE GAUNTLET STYLE GLOVES, INDIRECT VENT CHEMICAL SPLASH GOGGLES, SHOES, SOCKS, LONG SLEEVED SHIRT AND LONG PANTS.
-
- EXPOSURE TO ANHYDROUS AMMONIA (NH₃) WILL CAUSE SERIOUS INJURY OR DEATH. ONLY OPEN A NURSE TANK VALVE DURING APPLICATION. DO NOT TRANSPORT, PARK, OR LEAVE THE APPLICATOR UNATTENDED WITH THE VALVE OPEN.

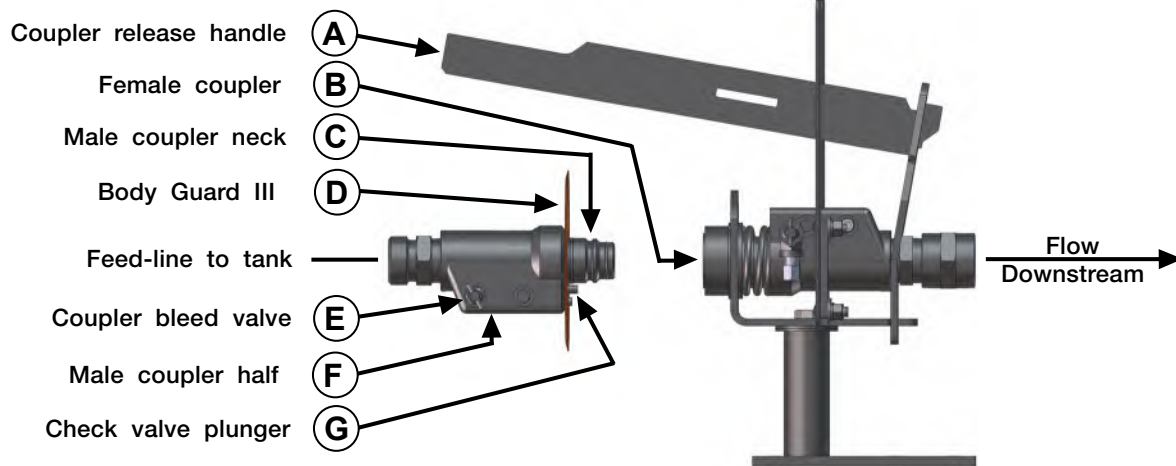

FIG. 4-2

Connecting

1. Stand on the upwind side. Close all feed-line valves and inspect all components for proper condition.
2. Relieve pressure between male coupler (F) and first shutoff valve towards nurse tank by carefully opening coupler bleed valve (E). The Flo-Max coupler is designed to re-couple safely with pressure on the female coupler half (B). (FIG. 4-2)

NOTE: Leave coupler bleed valve (E) open for now. (FIG. 4-2)

Coupler Operations (continued)

3. While holding and pointing the hose and male coupler (F) downwind and away from your person, depress check valve plunger (G) with gloved finger to ensure proper operation (FIG. 4-2 & FIG. 4-3). Wipe foreign debris from coupler neck (C) with clean cloth.
4. Make certain BodyGuard III (D) is installed fully with slot oriented around check valve plunger (G) to protect against ammonia spray-back during coupling (FIG. 4-2 & FIG. 4-4).
5. Insert male coupler neck (C) into female coupler half (B) as far as possible (FIG. 4-2 & FIG. 4-4).

NOTE: Then, while applying insertion pressure, pull downward on coupler release handle (A) to complete the coupling process. Release handle (A) after engagement of coupler neck (C) (FIG. 4-2 & FIG. 4-5).

6. Lightly pull on male coupler (F) to ensure proper engagement.
7. Close bleed valve (E) and others if open. Open tank and hose valves just prior to applying ammonia.

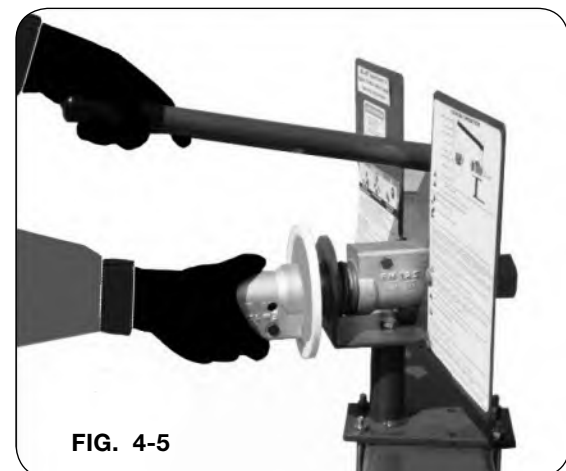
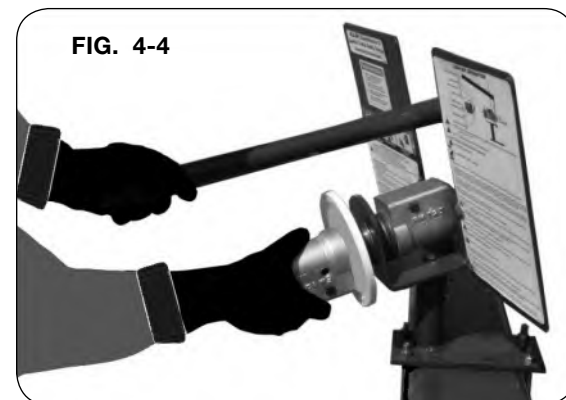
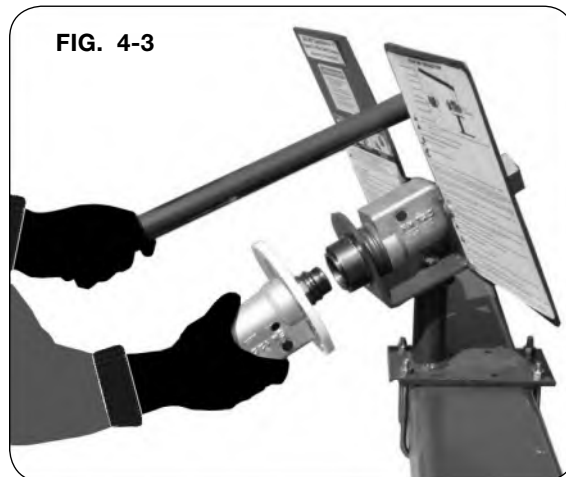

Disconnect

1. After closing all valves, bleed pressure from male coupler half (F) by opening coupler bleed valve (E). Leave bleed valve (E) open. (FIG. 4-2)
2. Then, pull down on coupler release handle (A) and remove male coupler half (F).

Electrical Layout - AgLeader Rate Controller

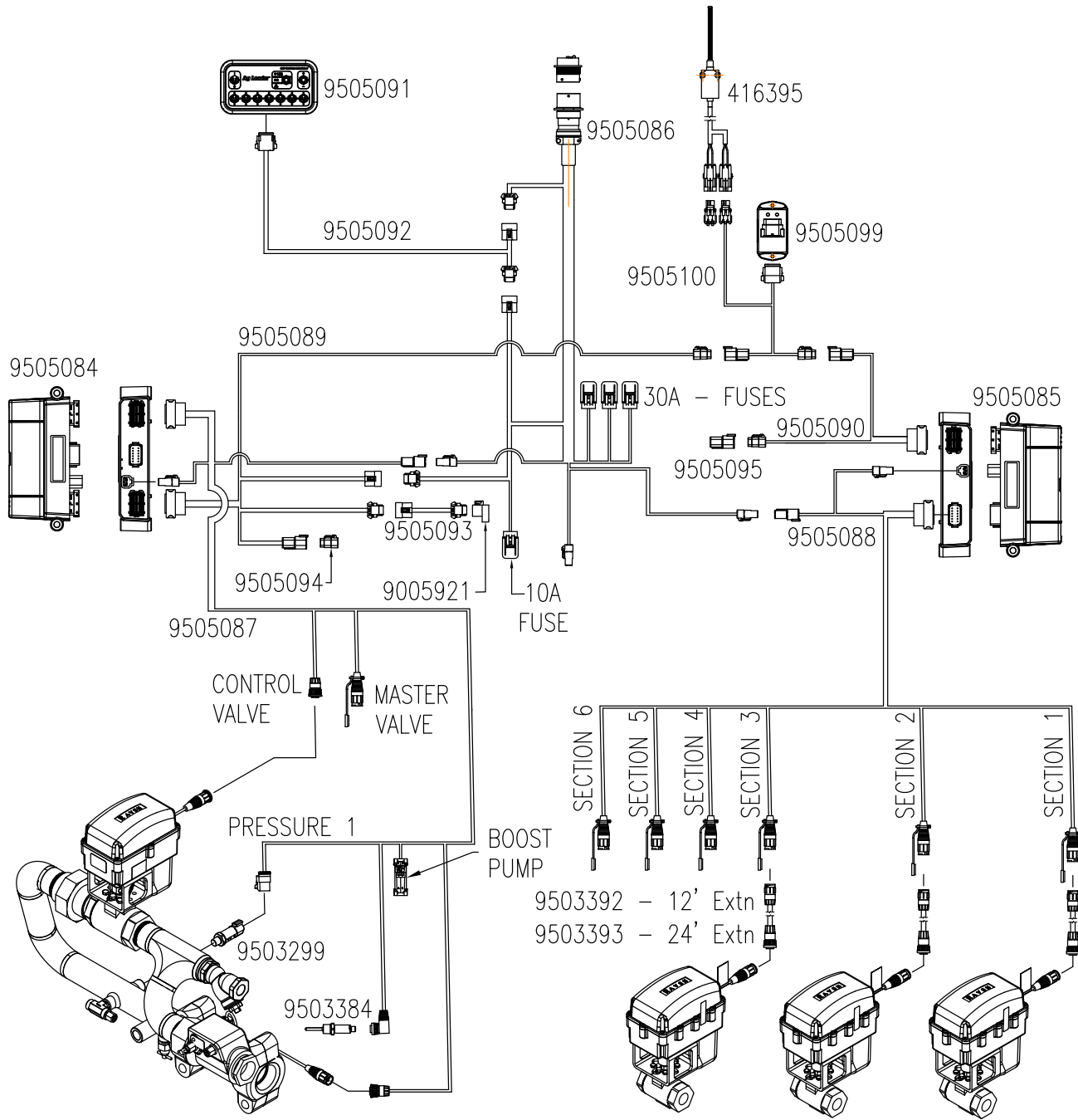

Electrical Layout - Raven 450 Rate Controller

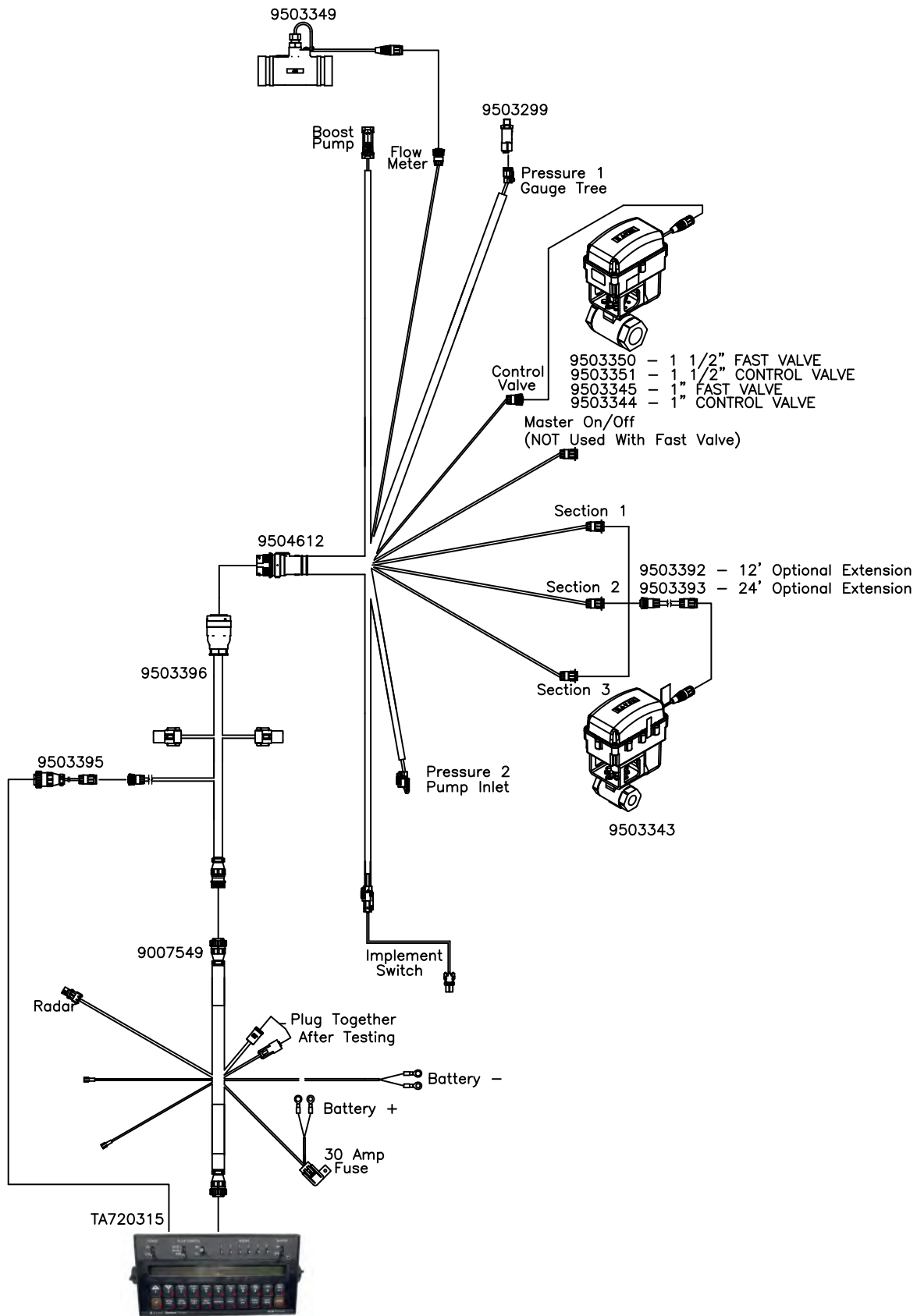

Electrical Layout - Lighting

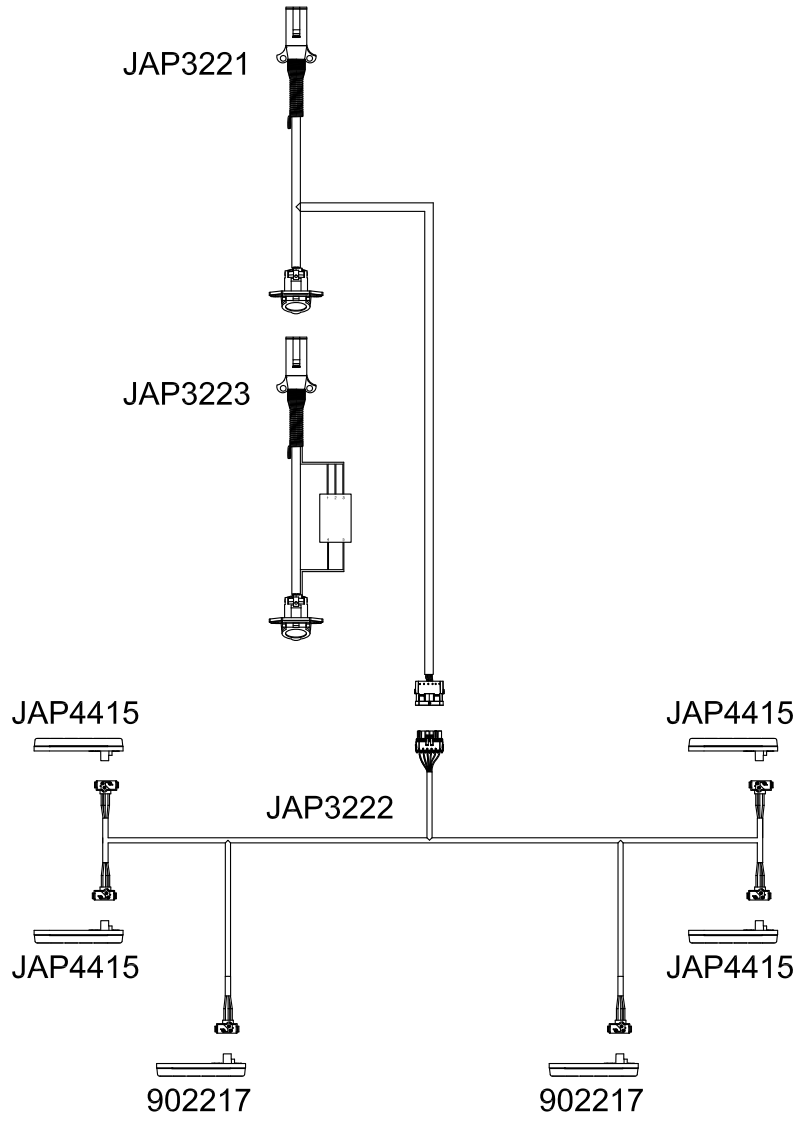

Schematic — Electrical

Electrical Harness - Limit Switch Assembly (416395)

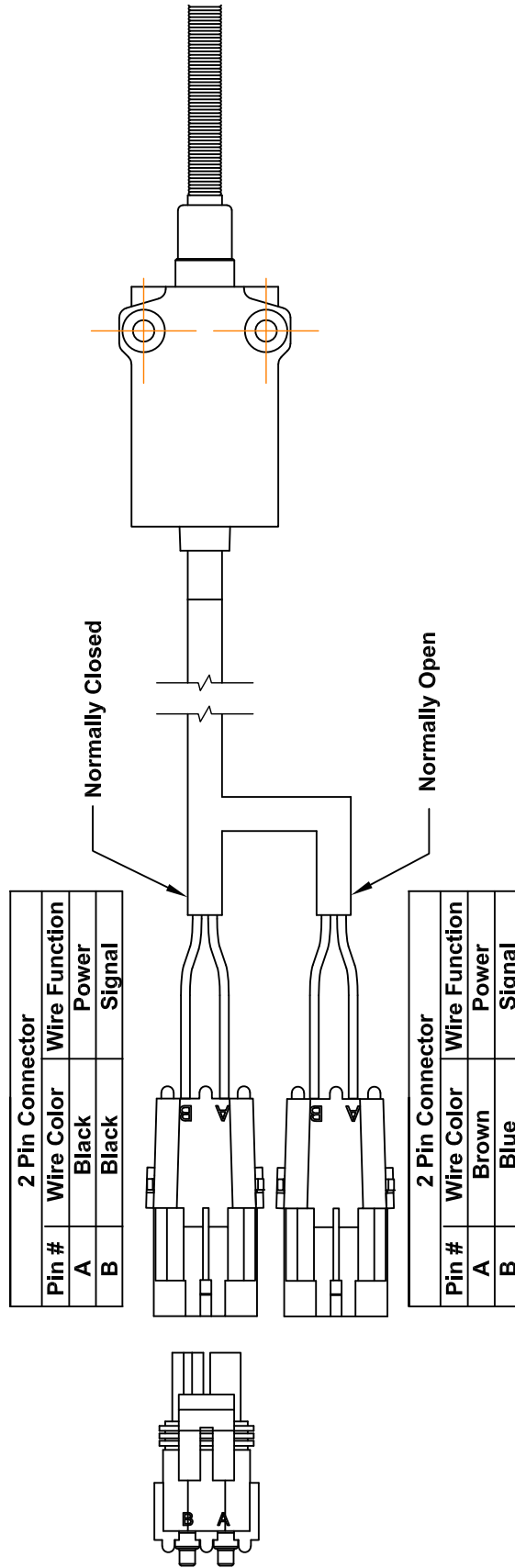

Schematic — Electrical (continued)

Electrical Harness - 450 Console Controller (9007549)

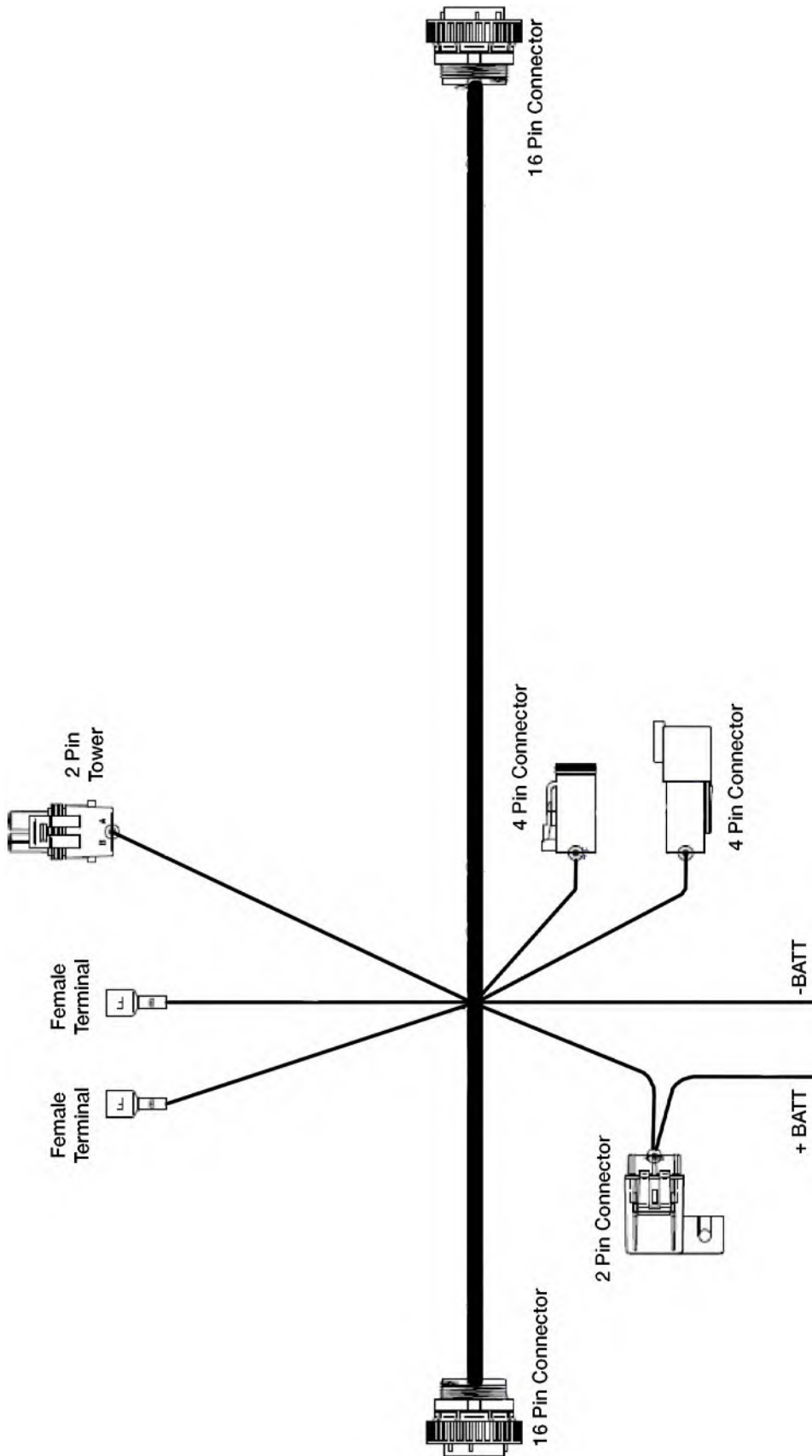

Schematic — Electrical (continued)

Electrical Harness - 12 Ft. Extension (9503392) - For On/Off Valve
Electrical Harness - 24 Ft. Extension (9503393) - For On/Off Valve

4-Pin Connector
Pin 1 - CBL-SLD
Pin 2 - CBL-BLK
Pin 3 - CBL-WHT
Pin 4 - CBL-RED

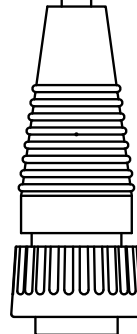

4-Pin Connector
Pin 1 - CBL-SLD
Pin 2 - CBL-BLK
Pin 3 - CBL-WHT
Pin 4 - CBL-RED

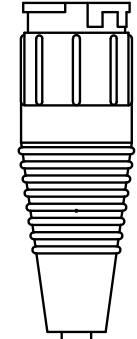

Schematic — Electrical (continued)

Electrical Harness - Console 10 Ft. (9503395) - Transducer to Console

PIN 1 - NONE
PIN 2 - NONE
PIN 3 - NONE
PIN 4 - NONE
PIN 5 - NONE
PIN 6 - NONE
PIN 7 - NONE
PIN 8 - CBL-RED
PIN 9 - CBL-WHT
PIN 10 - CBL-BLK
PIN 11 - NONE
PIN 12 - NONE
PIN 13 - NONE
PIN 14 - NONE

PIN 1 - CBL-WHT
PIN 2 - CBL-RED
PIN 3 - CBL-BLK

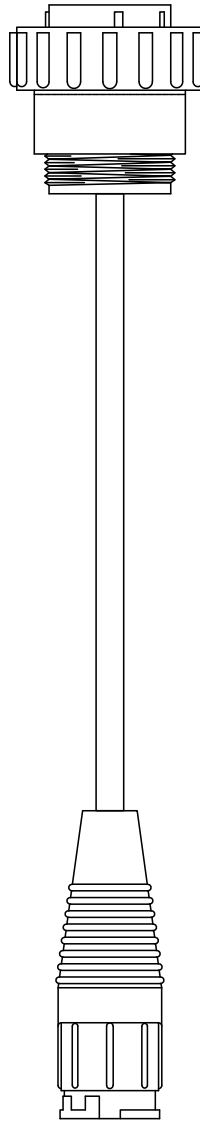

Schematic — Electrical (continued)

Electrical Harness - 16 Pin Console to 47 Pin Connector (9503396)

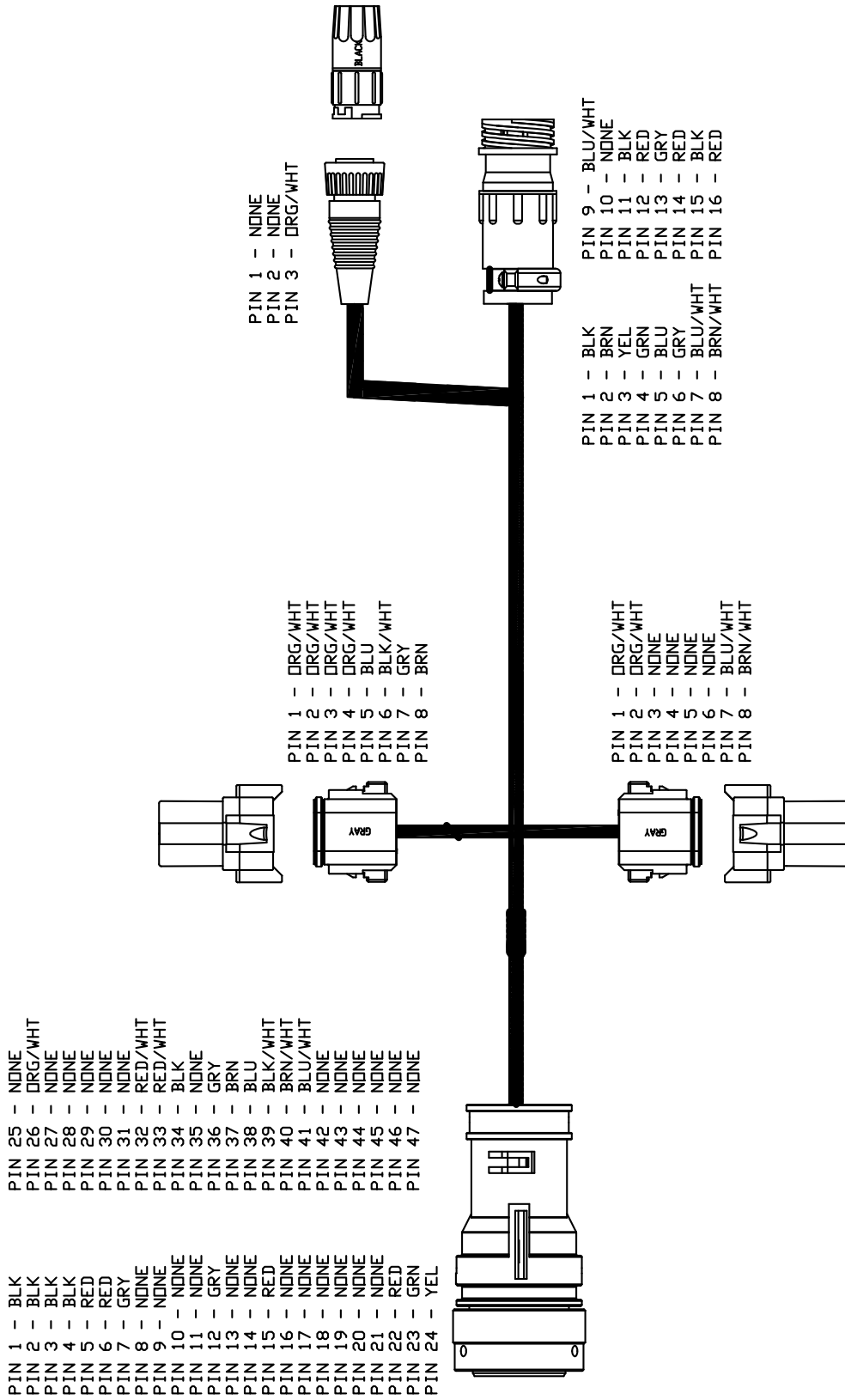

Schematic — Electrical (continued)

Electrical Harness - RCM Accu-Flow - 3 Section (9504612)

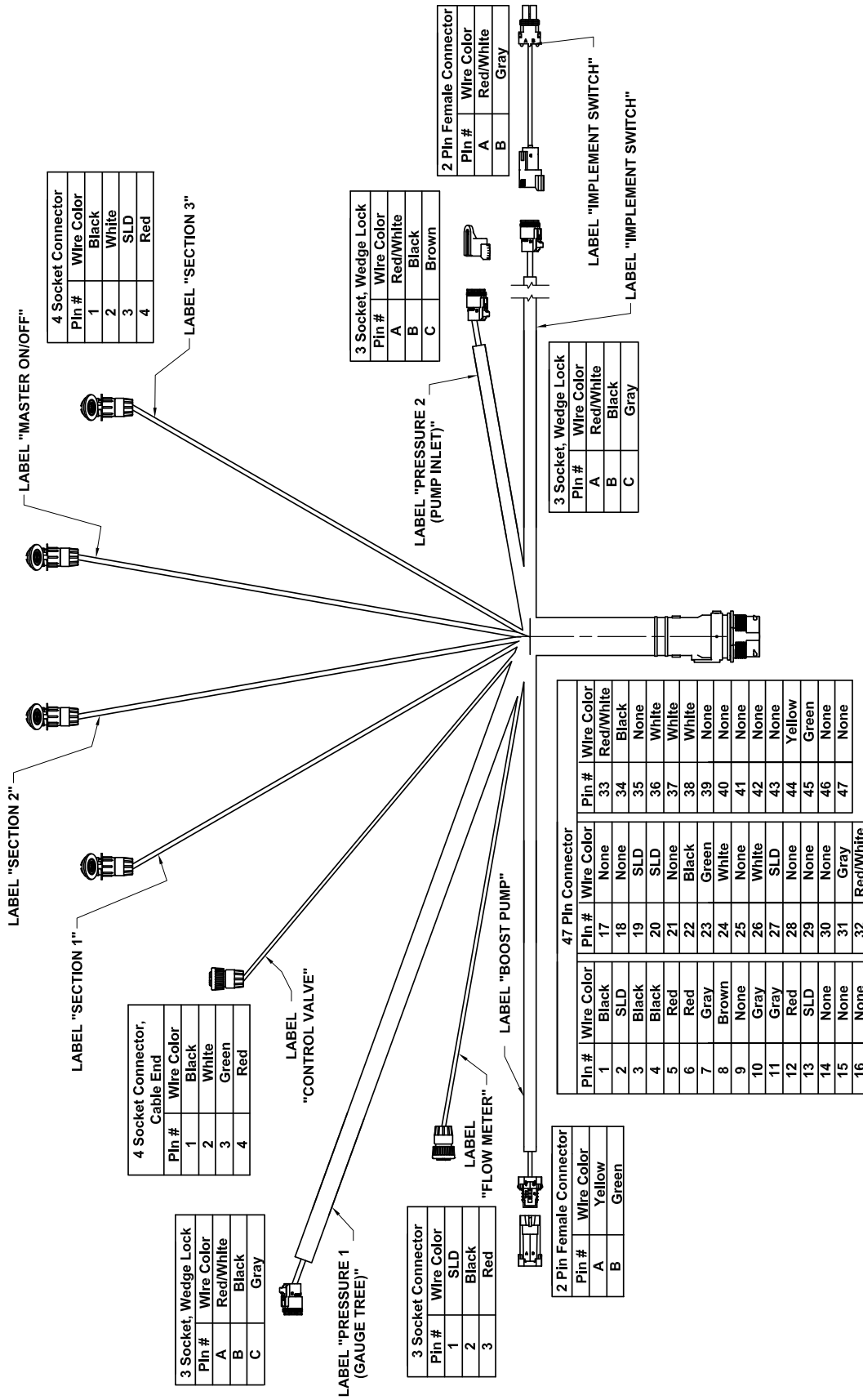

Schematic — Electrical (continued)

Electrical Harness - RCM Accu-Flow - 6 Section (9504613)

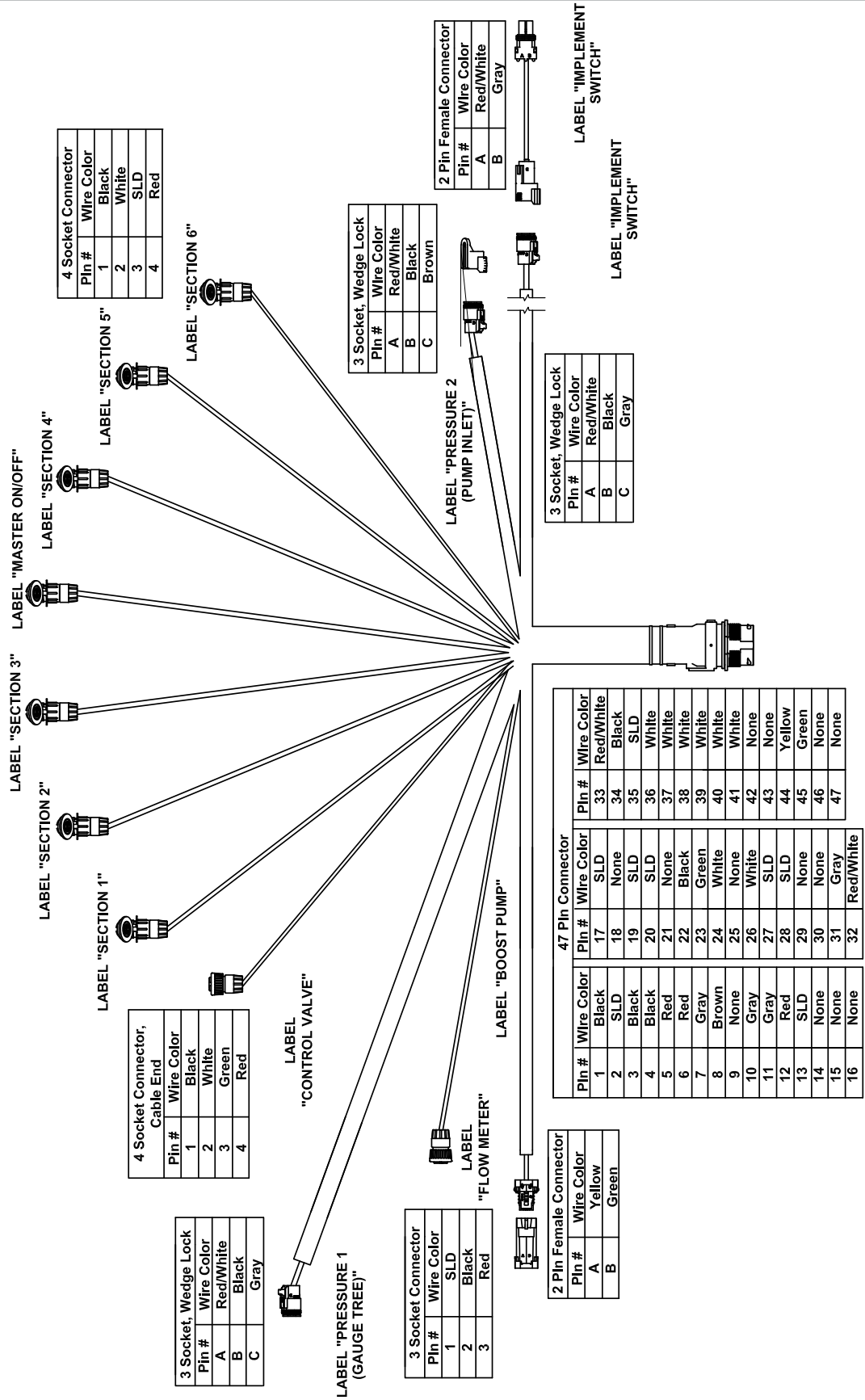

Schematic — Electrical (continued)

Electrical Harness - 16 Ft. Front IBIC (9505086)

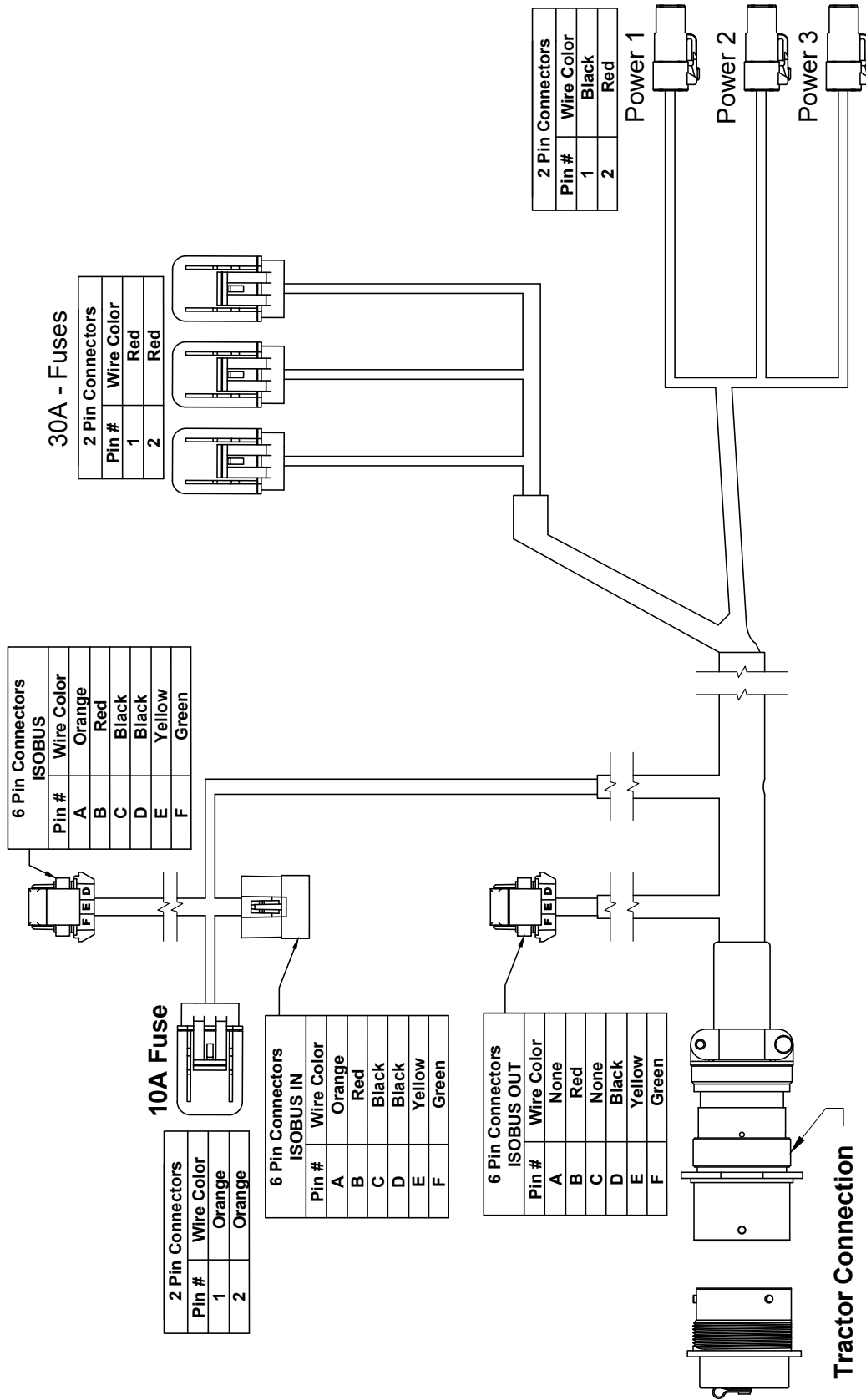

Schematic — Electrical (continued)

Electrical Harness - Flow Control Cable (9505087)

Module - 24 Pin Connectors		
Pin #	Description	Wire Color
1	Ground	Black
2	Ground	Black
3	Ground	Black
4	Ground	Black
5	Ground	Black
6	Ground	Black
7	Ground	Red
8	Power	Red
9	Power	Red
10	Power	Red
11	Power	Red
12	Valve Power	Red
13	Flow Meter Power	Red
14	Pressure Sensor Power	Red
15	Anhyd. Temp Power	Brown
16	Servo Closed	Black
17	Servo Open	White
18	Aux. Valve 1 Signal	Green
19	Aux. 2 Open	Blue
20	Aux. 2 Closed	Blue/White
21	Flow Meter Signal	White
22	Main Pressure Sensor	White
23	Anhyd. Temp Signal	Black
24	None	None

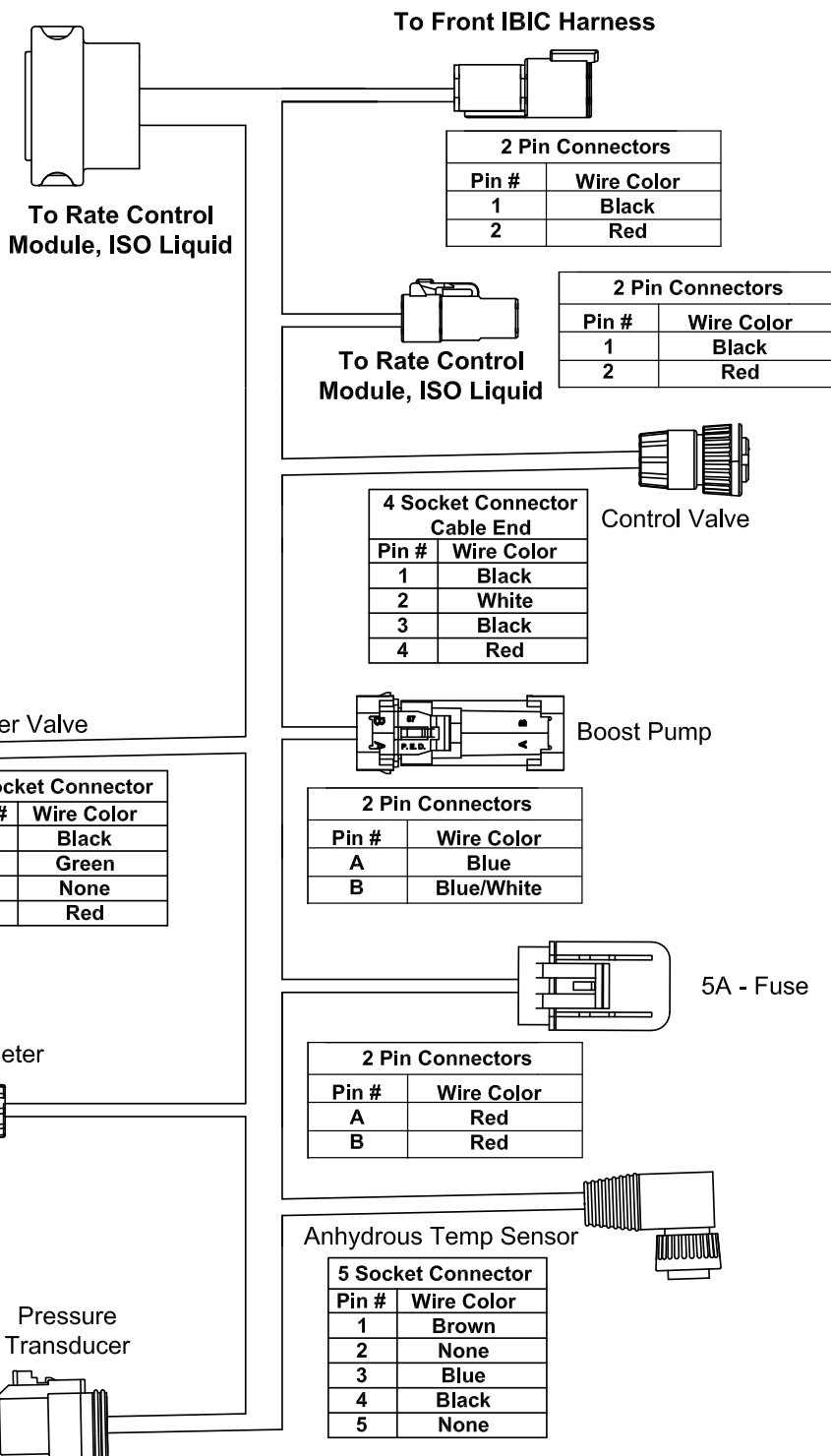

Schematic — Electrical (continued)

Electrical Harness - Swath Control - 6 Section (9505088)

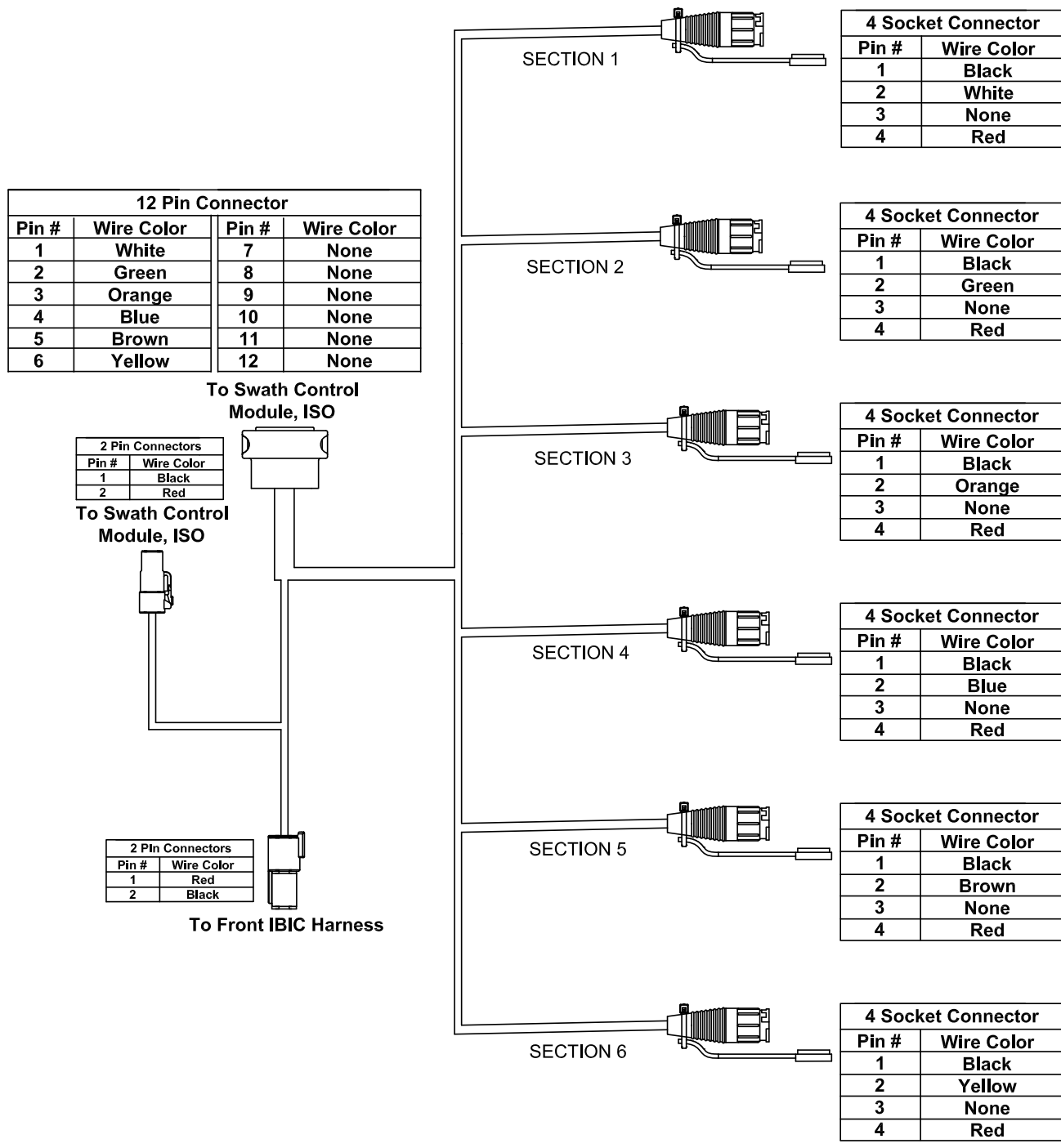

Schematic — Electrical (continued)

Electrical Harness - ISOBUS Breakout (9505089)

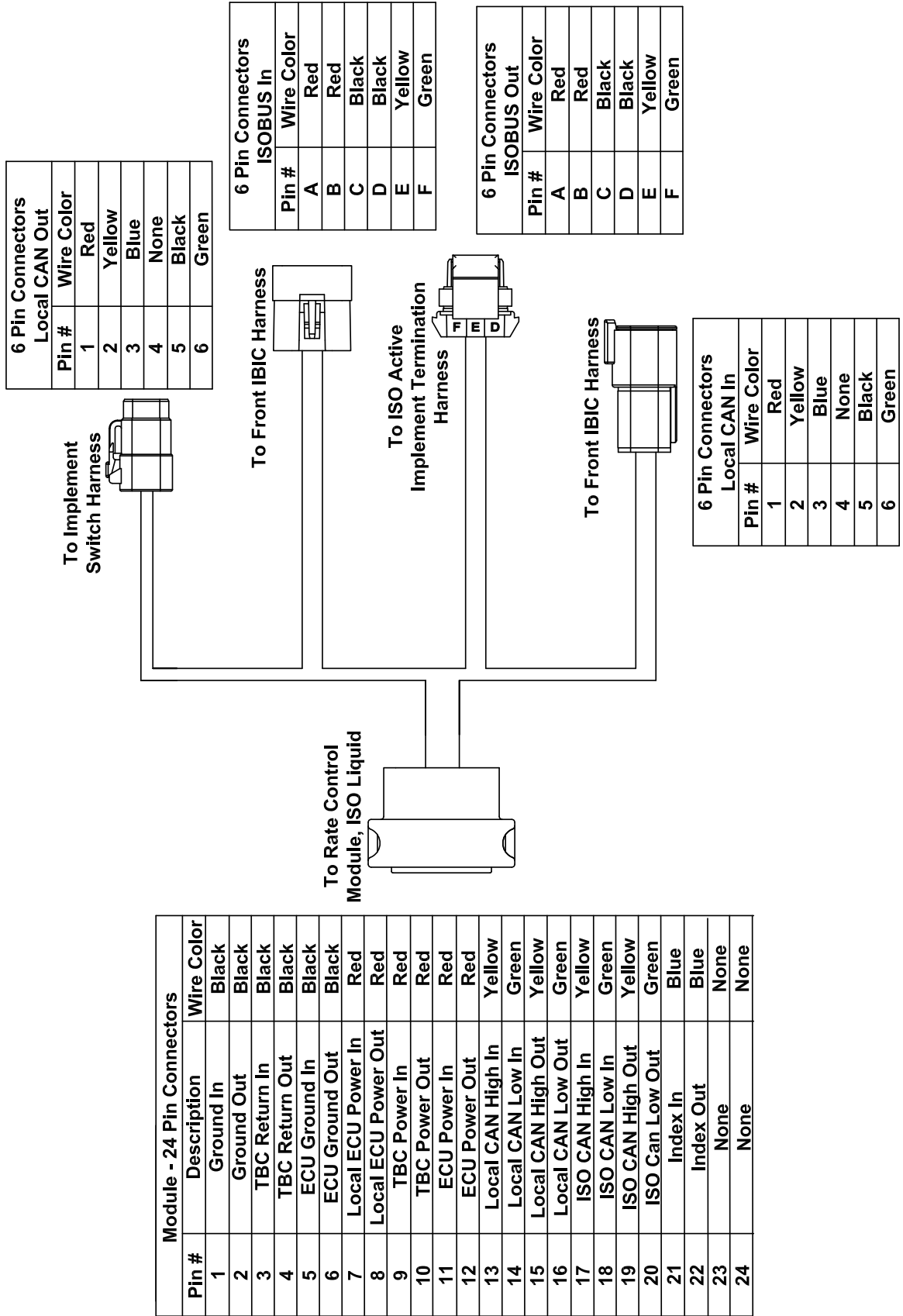

Schematic — Electrical (continued)

Electrical Harness - Local CAN Breakout (9505090)

6 Pin Connectors Local CAN In	
Pin #	Wire Color
1	Red
2	Yellow
3	Blue
4	None
5	Black
6	Green

Module - 24 Pin Connectors		
Pin #	Description	Wire Color
1	Ground	Black
2	Ground	Black
3	Ground	Black
4	Ground	Black
5	Ground	Black
6	Ground	Black
7	Ground	Red
8	Power	Red
9	Power	Red
10	Power	Red
11	Power	Red
12	Valve Power	Red
13	Flow Meter Power	Red
14	Pressure Sensor Power	Red
15	Anhyd. Temp Power	Brown
16	Servo Closed	Black
17	Servo Open	White
18	Aux. Valve 1 Signal	Green
19	Aux. 2 Open	Blue
20	Aux. 2 Closed	Blue/White
21	Flow Meter Signal	White
22	Main Pressure Sensor	White
23	Anhyd. Temp Signal	Black
24	None	None

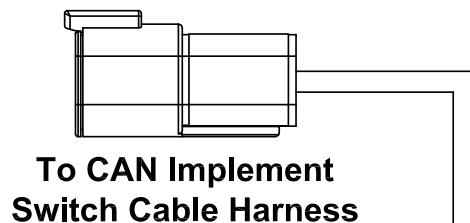

6 Pin Connectors Local CAN Out	
Pin #	Wire Color
1	Red
2	Yellow
3	Blue
4	None
5	Black
6	Green

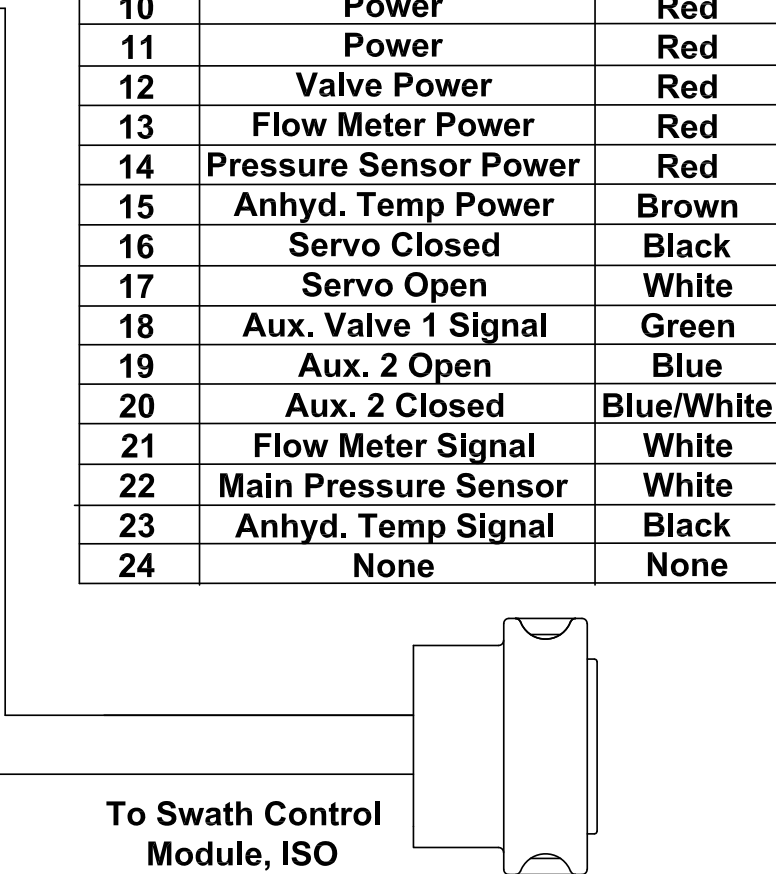
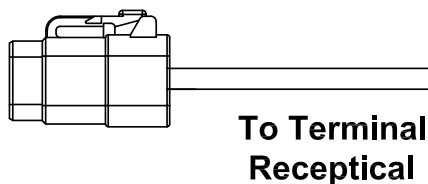

Schematic — Electrical (continued)

Electrical Harness - ISO Switchbox Metripack Tee (9505092)

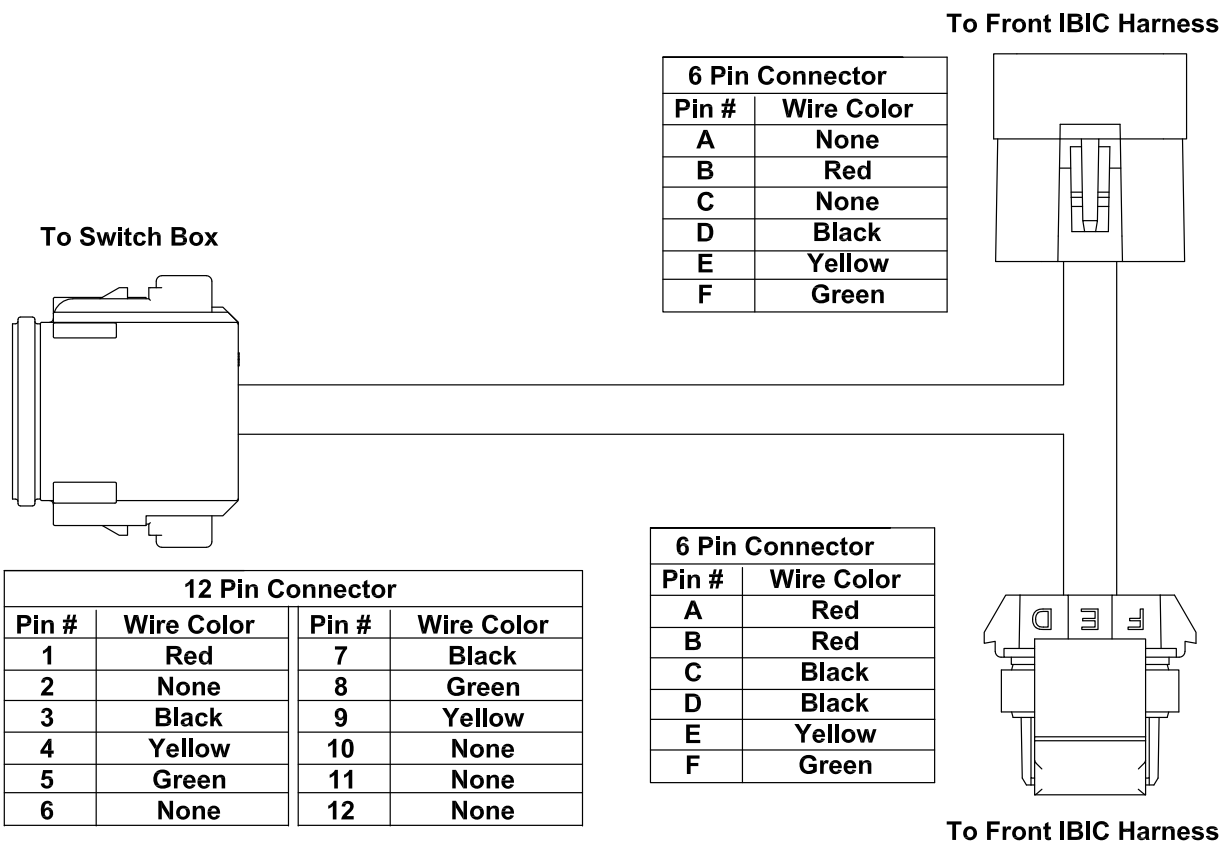

Electrical Harness - ISO Active Imp Termination (9505093)

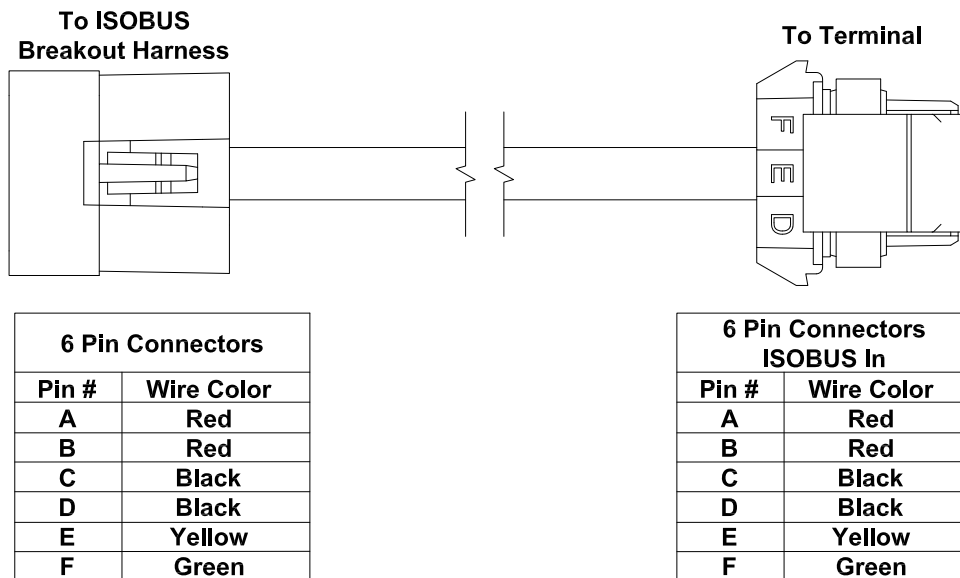

Schematic — Electrical (continued)

Electrical Harness - CAN Implement Switch Cable (9505100)

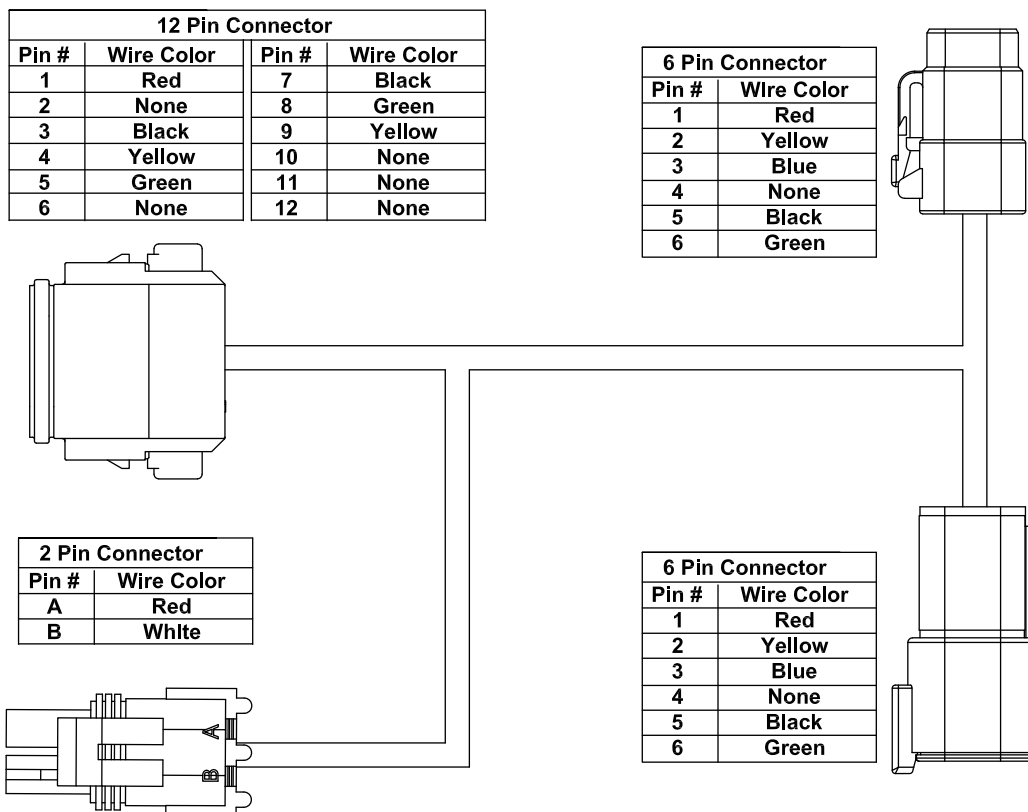

Electrical Harness - Main 33' (JAP3221)

- A. CONNECTOR: 7 F-TERMINAL PLUG CONFORMING TO SAE J560
- B. CONNECTOR: PACKARD, FLAT 6 M-TERMINAL WEATHER-PACK SHROUD
- C. CONNECTOR: 7 M-TERMINAL SOCKET CONFORMING TO SAE J560
- D. CABLE: 5-WIRE 16AWG, (WHT, YEL, RED, GRN, BRN)
- E. TRAILER CABLE: 7-WIRE, 12AWG (BLK, YEL, GRN, BRN), 10AWG (RED, BLU), 8AWG (WHT)

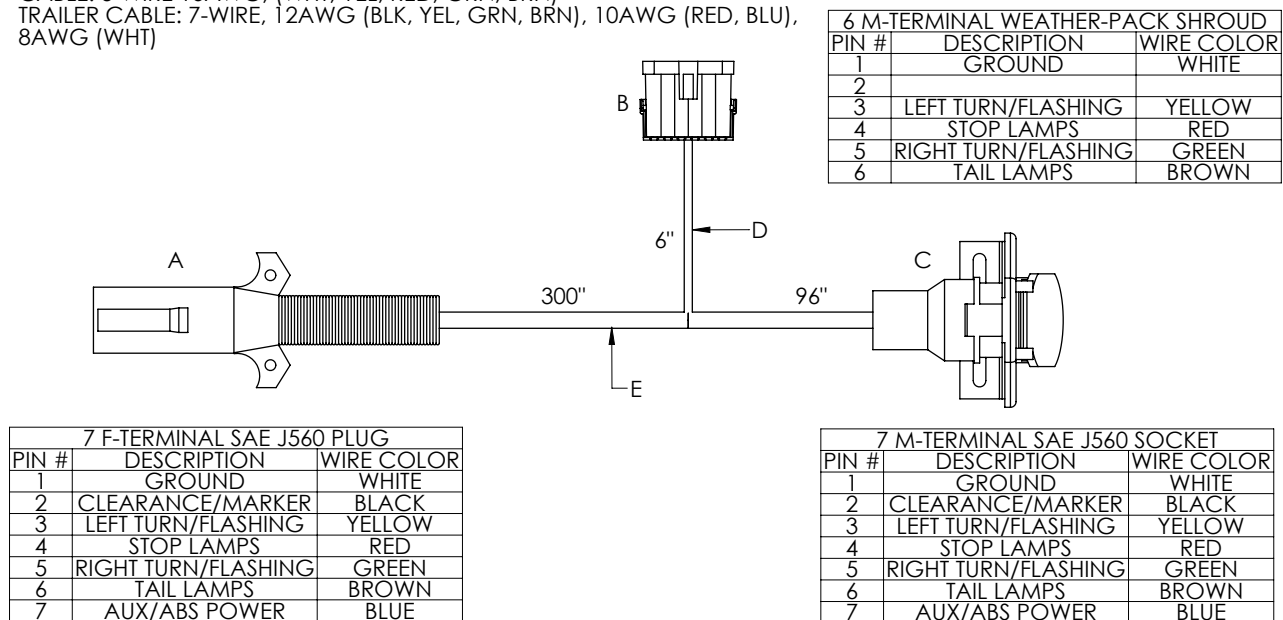

Schematic — Electrical (continued)

Electrical Harness - Rear 27' (JAP3222)

- A. CONNECTOR: PACKARD, FLAT 6-F TERMINAL WEATHER-PACK TOWER
- B. CONNECTOR: 3 M-TERMINAL RIGHT ANGLE LIGHT PLUG
- C. WIRE: 16AWG-COLORS: WHITE, YELLOW, RED, GREEN, BROWN

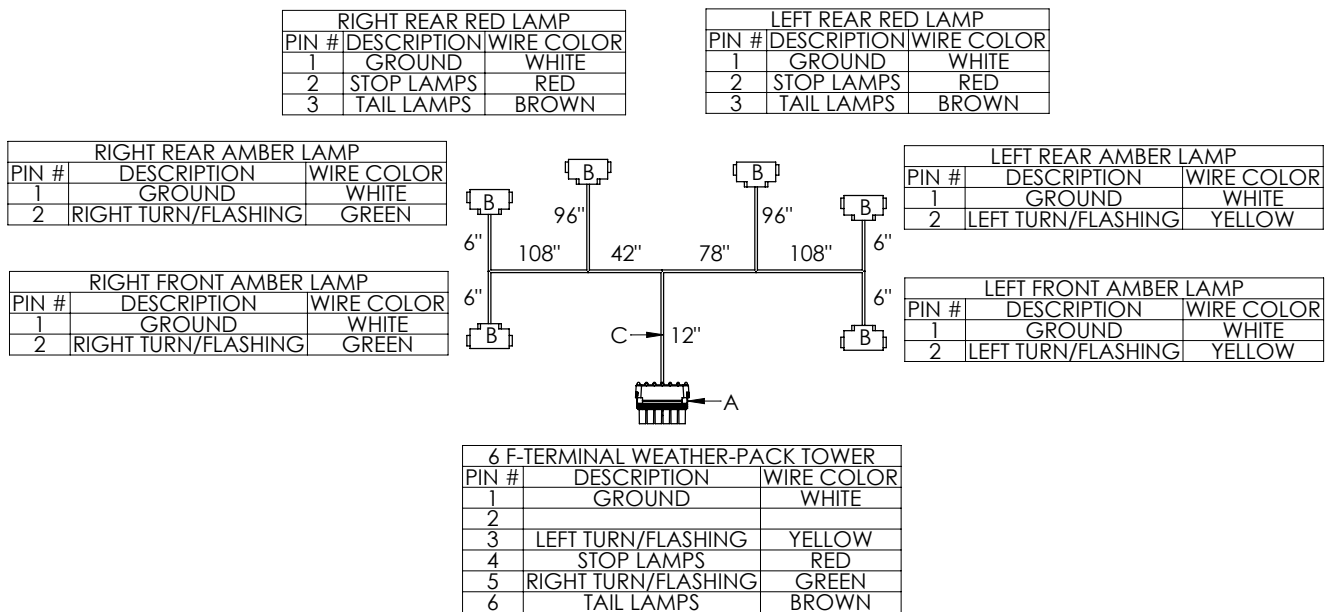

Electrical Harness - AG Plug to RV Socket (JAP3223)

- A. CONNECTOR: 7 F-TERMINAL PLUG CONFORMING TO SAE J560
- B. TAIL LIGHT CONVERTER: POLLAK 12-752
- C. CONNECTOR: 7 M-TERMINAL SOCKET, RV BLADE STYLE
- D. CABLE: 2-WIRE 12AWG, (WHITE, BLACK)

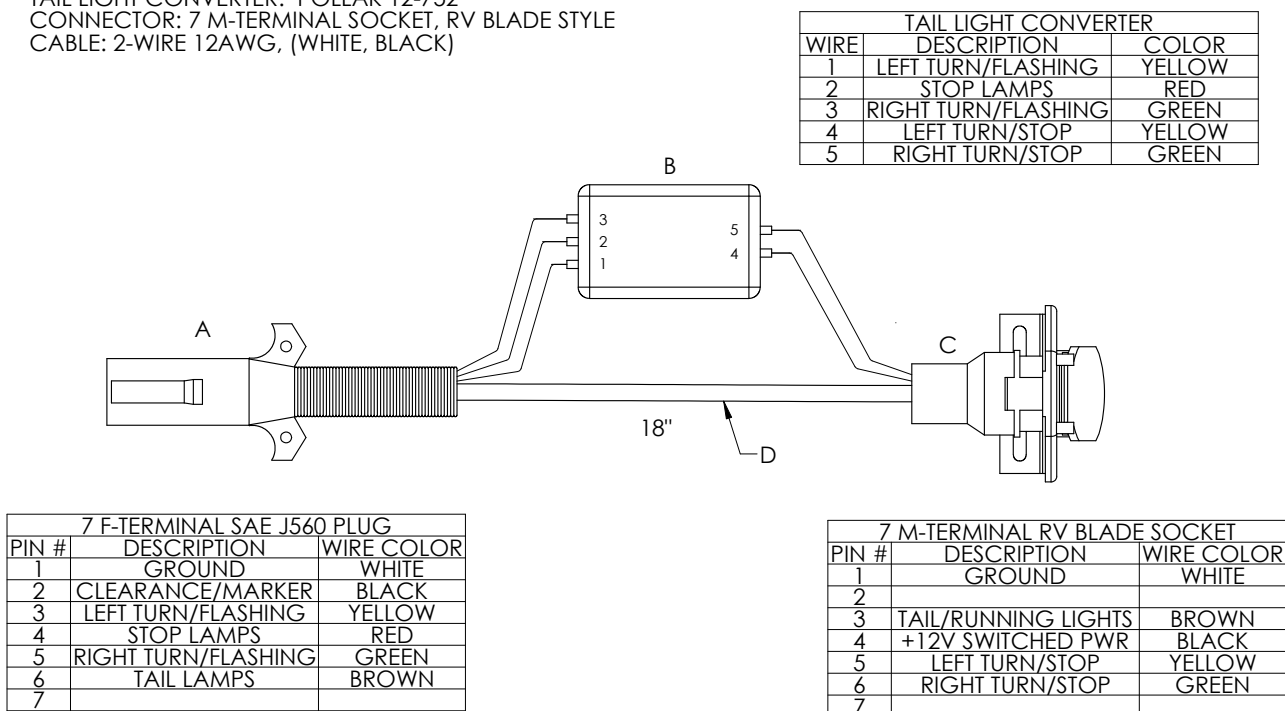

Wheel, Hub and Spindle Disassembly and Assembly

WARNING

- TIPPING OR MOVEMENT OF THE MACHINE CAN CAUSE SERIOUS INJURY OR DEATH. BE SURE MACHINE IS SECURELY BLOCKED.
- FALLING OBJECTS CAN CAUSE SERIOUS INJURY OR DEATH. DO NOT WORK UNDER THE MACHINE AT ANY TIME WHILE BEING HOISTED. BE SURE ALL LIFTING DEVICES AND SUPPORTS ARE RATED FOR THE LOADS BEING HOISTED. THESE ASSEMBLY INSTRUCTIONS WILL REQUIRE SAFE LIFTING DEVICES UP TO 30,000 LBS. SPECIFIC LOAD RATINGS FOR INDIVIDUAL LOADS WILL BE GIVEN AT THE APPROPRIATE TIME IN THE INSTRUCTIONS.
- EYE PROTECTION AND OTHER APPROPRIATE PERSONAL PROTECTIVE EQUIPMENT MUST BE WORN WHILE SERVICING IMPLEMENT.
- KEEP HANDS CLEAR OF PINCH POINT AREAS.

CAUTION

- IMPROPERLY TORQUED WHEEL NUTS/BOLTS CAN CAUSE A LOSS OF IMPLEMENT CONTROL AND MACHINE DAMAGE. TORQUE WHEEL NUTS/BOLTS TO VALUES IN TABLE. CHECK TORQUE BEFORE USE, AFTER ONE HOUR OF UNLOADED USE OR AFTER FIRST LOAD, AND EACH LOAD UNTIL WHEEL NUTS/BOLTS MAINTAIN TORQUE VALUE. CHECK TORQUE EVERY 10 HOURS OF USE THERE-AFTER. AFTER EACH WHEEL REMOVAL START TORQUE PROCESS FROM BEGINNING. WARRANTY DOES NOT COVER FAILURES CAUSED BY IMPROPERLY TORQUED WHEEL NUTS/BOLTS.

IMPORTANT

- *Remove only one wheel and tire from a side at any given time in the following procedure.*
1. Hitch implement to tractor. Park on a firm, level surface. Set the tractor's parking brake, shut off engine and remove key.
 2. Use a safe lifting device rated at 30,000 lbs. to support the weight of your implement. Place the safe lifting device under the axle closest to the tire.
 3. Use a 300 lbs. safe lifting device to support the wheel and tire during removal.
 4. If only removing wheel and tire, skip to Step 8; otherwise continue with Step 4.



Remove the hardware retaining the hubcap. Next, remove the hubcap, gasket, cotter pin, castle nut and spindle washer. Remove hub with bearings from old spindle using a 200 lbs. lifting device.

Wheel, Hub and Spindle Disassembly and Assembly (continued)

5. Inspect the spindle and replace if necessary. If spindle does not need to be replaced, skip to Step 6; otherwise continue with Step 5.

Remove the bolt and lock nut that retain the spindle to the axle. Using a lifting device rated for 200 lbs., remove the old spindle. Coat spindle shaft with anti-seize lubricant prior to installation. Reuse bolt and lock nut to retain spindle to axle. Torque as outlined in Maintenance Section.

6. Remove seal and inspect bearings, spindle washer, castle nut and cotter pin. Replace if necessary. Pack both bearings with Extreme Pressure NLGI #2 grease and reinstall inner bearing. Install new seal in hub with garter spring facing inward to the hub by tapping on flat plate that completely covers seal while driving it square to hub. Install until flush with back face of hub. Using a 200 lb. rated lifting device, install hub assembly onto spindle. Install outer bearing, spindle washer and castle nut.

IMPORTANT

- *Do not use an impact wrench!*

7. Slowly tighten castle/slotted nut while spinning the hub until hub stops rotating. Turn castle nut counterclockwise until the hole in the spindle aligns with the next notch in castle nut. Hub should spin smoothly with minimal drag and no end play. If play exists, tighten to next notch of castle nut. If drag exists, then back castle nut to next notch. Spin and check again. Install cotter pin. Clean face for hub cap gasket and install gasket, grease-filled hub cap and retain hubcap with hardware removed. Tighten hubcap hardware in alternating pattern.
8. Attach the wheel(s) and tire(s) to the hub using the same rated safe lifting device for removal. Tighten wheel nuts to appropriate requirements and recheck as outlined in the Wheels and Tires section of this manual.
9. Raise implement, remove lifting device and lower tire to the ground.

Wheels and Tires

Wheel Nut Torque Requirements

CAUTION

- IMPROPERLY TORQUED WHEEL NUTS/BOLTS CAN CAUSE A LOSS OF IMPLEMENT CONTROL AND MACHINE DAMAGE. TORQUE WHEEL NUTS/BOLTS TO VALUES IN TABLE. CHECK TORQUE BEFORE USE, AFTER ONE HOUR OF UNLOADED USE OR AFTER FIRST LOAD, AND EACH LOAD UNTIL WHEEL NUTS/BOLTS MAINTAIN TORQUE VALUE. CHECK TORQUE EVERY 10 HOURS OF USE THEREAFTER. AFTER EACH WHEEL REMOVAL START TORQUE PROCESS FROM BEGINNING. WARRANTY DOES NOT COVER FAILURES CAUSED BY IMPROPERLY TORQUED WHEEL NUTS/BOLTS.

Failure to check torque before first use may damage wheel nut/bolt seats. Once seats are damaged, it will become impossible to keep nuts/bolts tight. Tighten nuts/bolts to applicable torque value shown in table. Start all nuts/bolts by hand to prevent cross threading. Torque nuts/bolts in the recommended sequence as shown in Diagram 1.

WHEEL HARDWARE	
SIZE	FOOT-POUNDS
1/2"-20(UNF) Grade 5	75 Ft.-Lbs.
5/8"-18(UNF) Grade 5	165 Ft.-Lbs.
5/8"-18(UNF) Grade 8	175 Ft.-Lbs.

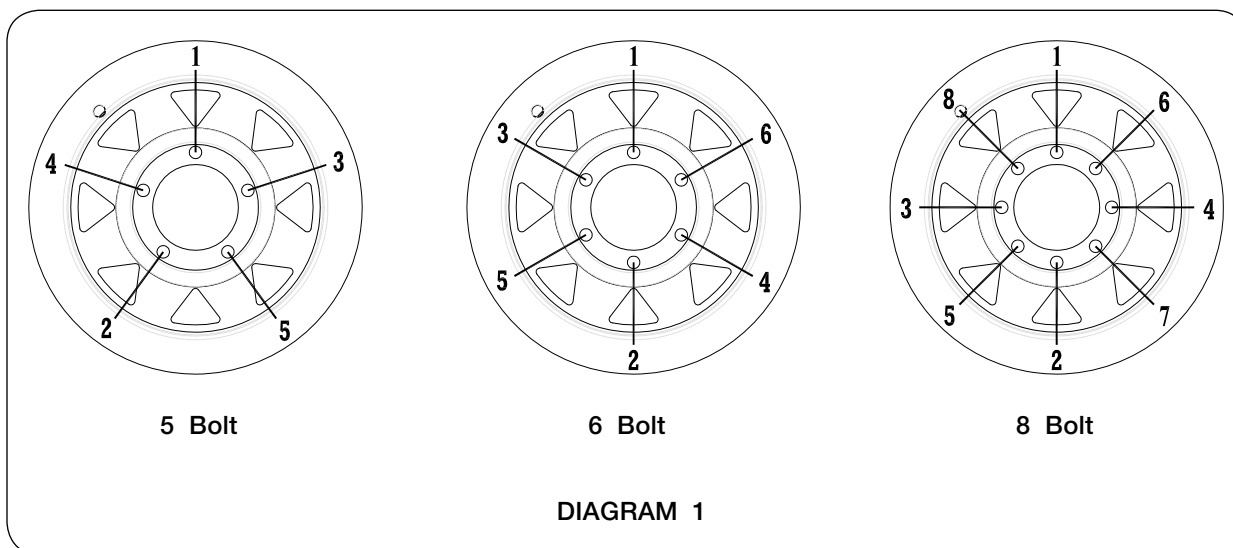

Wheels and Tires (continued)**Tire Pressure**

The following is to be used as a general guide for tire inflation and figures can vary depending on specific brand of tire used. It is important that tires are inspected after unit is loaded. The tire should stand up with no side-wall buckling or distress as tire rolls. Record the pressure needed to support the full load and maintain this pressure to achieve proper tire life. Do not exceed maximum recommended tire pressure.

Tire Pressure for Blu-Jet Applicators				
Tire Make	Tire Size	Load Index / Ply Rating	Tread	Max PSI
Carlisle	20.5x8.0B10			
	11L15	F-Ply	I-1	90
Firestone	VF385/65R22.5	163D	I-1	70
	VF295/75R22.5	151D	I-1	64
	30.5R32	16-Ply	R-3	26
Goodyear	12.4R38	14-Ply	R-1	56
	12.5LB15			90
Mitas	380/85R34	146A8		44
	VF380/90R46	173D	R-1	64
Titan	7.50-15	6-Ply	HF-1	44
	155/80R12			

(All tire pressures in psi)

Wheels and Tires (continued)

Tire Warranty

For questions regarding new tire warranty, please contact your local original equipment tire dealer. Used tires carry no warranty. Following are phone numbers and Websites for your convenience:

Firestone www.firestoneag.com
Phone 800-847-3364

Titan www.titan-intl.com
or Phone 800-USA-BEAR
Goodyear Fax 515-265-9301

Carlisle/Ironman www.carlisletire.com
Phone 800-260-7959
Fax 800-352-0075

Complete Torque Chart

Cap screws - Grade 5

NOTE:

- Grade 5 cap screws can be identified by three radial dashes on the head.
- For wheel torque requirements, refer to Wheels and Tires.
- Tighten U-bolts evenly and equally to have the same number of threads exposed on each end.



SIZE	FOOT POUNDS	NEWTON METERS
1/4-20	8-10	11-13
1/4-28	9-11	12-15
5/16-18	15-17	20-23
5/16-24	17-19	23-26
3/8-16	25-28	34-38
3/8-24	28-31	38-42
7/16-14	40-45	54-61
7/16-20	45-50	61-68
1/2-13	62-68	84-92
1/2-20	68-75	92-102
9/16-12	90-98	122-133
9/16-18	100-110	134-148
5/8-11	120-135	162-183
5/8-18	124-137	168-186
3/4-10	200-220	270-300
3/4-16	210-230	285-310
7/8-9	330-350	425-475
7/8-14	360-380	460-515
1-8	500-525	675-710
1-14	540-560	730-760
1 1/8-7	600-635	815-860
1 1/8-12	665-700	920-950
1 1/4-7	850-895	1150-1215
1 1/4-12	940-990	1275-1340
1 3/8-6	1125-1175	1525-1590
1 3/8-12	1280-1335	1735-1810
1 1/2-6	1500-1560	2035-2115
1 1/2-12	1685-1755	2285-2380

IMPORTANT

- Follow these torque recommendations except when specified in text.

Complete Torque Chart

Cap screws - Grade 8

NOTE:

- Grade 8 cap screws can be identified by six radial dashes on the head.
- For wheel torque requirements, refer to Wheels and Tires.
- Tighten U-bolts evenly and equally to have the same number of threads exposed on each end.



SIZE	FOOT POUNDS	NEWTON METERS
5/16-18	20-22	27-30
5/16-24	21-23	28-31
3/8-16	35-39	47-53
3/8-24	36-41	49-55
7/16-14	54-58	73-78
7/16-20	55-60	75-80
1/2-13	82-88	110-120
1/2-20	94-99	125-135
9/16-12	127-134	170-180
9/16-18	147-155	199-210
5/8-11	160-170	215-230
5/8-18	165-175	225-235
3/4-10	280-295	380-400
3/4-16	330-365	445-495
7/8-9	410-430	555-580
7/8-14	420-440	570-595
1-8	630-650	850-880
1-14	680-700	920-950
1 1/8-7	900-930	1220-1260
1 1/8-12	930-950	1260-1290
1 1/4-7	1250-1300	1695-1760
1 1/4-12	1280-1320	1735-1790

IMPORTANT

- Follow these torque recommendations except when specified in text.

Hydraulic Fittings - Torque and Installation

Tightening O-Ring Fittings

1. Inspect components for damage or contamination. Do not connect any other type of fitting to an O-ring fitting.
2. For adjustable fittings, insure the jam nut and washer are fully backed up.
3. Lubricate the O-ring and threads on the fitting.
4. Turn the fitting into the port until it is finger tight.
5. For adjustable fittings, set in the desired position.
6. Using a wrench, torque the fitting to the value in the below table. For adjustable fittings the jam nut will be tightened.

NOTE: Never use a power tool to install a fitting.

Dash Size	Thread Size	Straight Stud Torque (Ft-Lbs)	Adjustable Stud Torque (Ft-Lbs)
-5	1/2-20	14-19	10-14
-6	9/16-18	18-24	12-16
-8	3/4-16	27-43	20-30
-10	7/8-14	36-48	30-36
-12	1-1/16-12	65-75	44-54
-14	1-3/16-12	75-99	53-70
-16	1-5/16-12	85-123	59-80
-20	1-5/8"-12	115-161	75-100
-24	1-7/8"-12	125-170	105-125

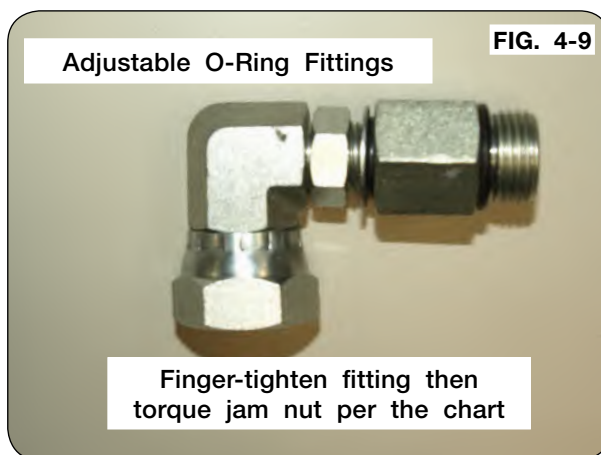
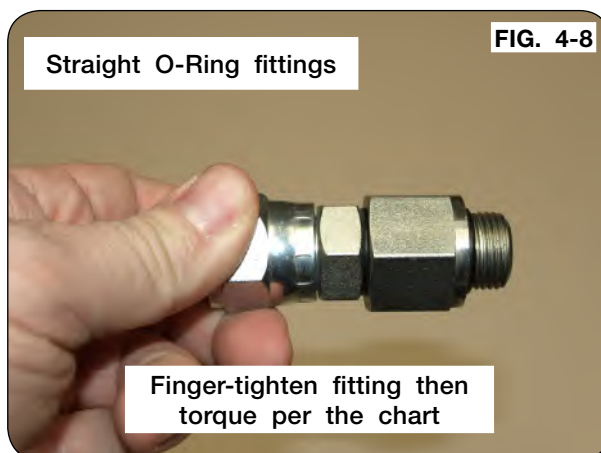

Hydraulic Fittings - Torque and Installation (continued)**Tightening JIC Fittings**

1. Inspect all components for damage or contamination. Do not connect any other type of fitting to a JIC fitting.
2. Lubricate the threads.
3. Turn the fitting into the port until it bottoms out.
4. Use one wrench on the fixed hex on the hose to prevent twisting and a second on the swivel. Tighten the fitting another 60 degrees (or one flat)

NOTE: Never use a power tool to install a fitting.

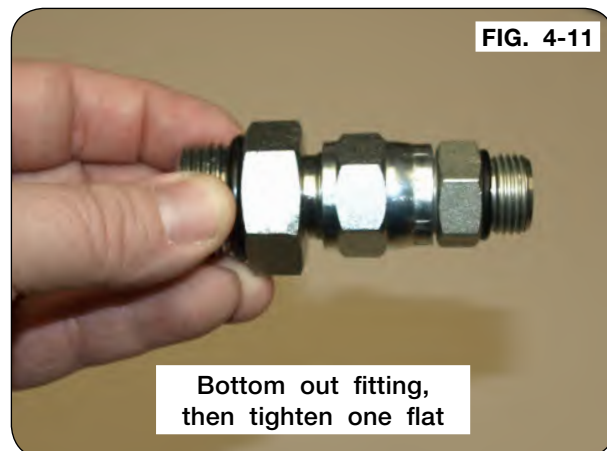

NH3 Fittings - Torque and Installation

NH3 Connections

The proper method of assembling pipe threaded connectors is to assemble them finger tight and then wrench tighten further to the specified number of turns from finger tight (T.F.F.T.) given in the table below. The assembly procedure given below is recommended to minimize the risk of leakage and/or damage to components.

1. Inspect port and connectors to ensure that threads on both are free of dirt, burrs and excessive nicks.
2. Apply thread sealant approved for anhydrous ammonia to male pipe threads. The first one to two threads should be left uncovered to avoid system contamination. Apply sealant as directed by the manufacturer.

CAUTION

- MORE THAN TWO TURNS OF TAPE MAY CAUSE DISTORTION OR CRACKING OF THE PORT.

3. Screw the connector into the port to the finger tight position.
4. Wrench tighten the connector to the appropriate turns from finger tight (T.F.F.T) values shown in the table, making sure that the tube end of a shaped connector is aligned to receive the incoming tube or hose assembly.

IMPORTANT

- Never back off (loosen) pipe threaded connectors to achieve alignment.
5. If leakage persists after following the above steps, check for damaged threads and total number of threads engaged.

Thread Size NPTF		Threads Per Inch	Pitch	D	G	Assembly Turns (Steel)
						T.F.F.T.
1/8"	in mm	27	0.037 0.94	0.40 10.24	0.16 4.1	2 - 3
1/4"	in mm	18	0.056 1.41	0.54 13.61	0.23 5.8	2 - 3
3/8"	in mm	18	0.056 1.41	0.67 17.05	0.24 6.1	2 - 3
1/2"	in mm	14	0.071 1.81	0.84 21.22	0.32 8.1	2 - 3
3/4"	in mm	14	0.071 1.81	1.05 26.56	0.34 8.6	1.5 - 2.5
1 1/4"	in mm	11 1/2	0.087 2.21	1.33 33.78	0.42 10.7	1.5 - 2.5
1 1/2"	in mm	11 1/2	0.087 2.21	1.89 48.05	0.42 10.7	1.5 - 2.5

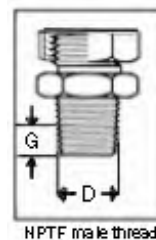



Unverferth[®]
Manufacturing Company, Inc.

www.unverferth.com